

Electric Chain Hoist (Single Brake)

Hoist Specifications

Capacity (Ton)	Model Number	No. of Chain Falls	Lift Speed (FPM)	HP	Rated Current	
					230 V (Amp)	460 V (Amp)
1/4	NECH*-00526-†	1	26	1	3.2	1.8
1/2	NECH*-01026-†	1	26	1	3.2	1.8
1	NECH*-02013-†	2	13	1	3.2	1.8
1/2	NECH*-01016-†	1	16	1.5	4.2	2.1
1	NECH*-02016-†	1	16	1.5	4.2	2.1
2	NECH*-04008-†	2	8	1.5	4.2	2.1
3	NECH*-06005-†	3	5	1.5	4.2	2.1
1	NECH*-02026-†	1	26	2	6.4	3.2
2	NECH*-04013-†	2	13	2	6.4	3.2
3	NECH*-06009-†	3	9	2	6.4	3.2
2	NECH*-04026-†	1	26	4	12.8	6.4
3	NECH*-06017-†	2	17	4	12.8	6.4
5	NECH*-10010-†	2	10	4	12.8	6.4
7.5	NECH*-15007-†	3	7	4	12.8	6.4
10	NECH*-20010-†	4	10	2X4	32.8	12.8
15	NECH*-30007-†	6	7	2X4	32.8	12.8
20	NECH*-40005-†	8	5	2X4	32.8	12.8
25	NECH*-50005-†	8	5	2X4	32.8	12.8
30	NECH*-60003-†	10	3	2X4	32.8	12.8
35	NECH*-70003-†	10	3	2X4	32.8	12.8

To complete your Model Number insert the following in place of asterisks:

- * Suspension Type:
 - H = Hook Mounted
 - L = Lug Mounted
 - M = With Motorized Trolley
 - P = With Push Trolley
 - G = With Geared Trolley

† Lift, in feet



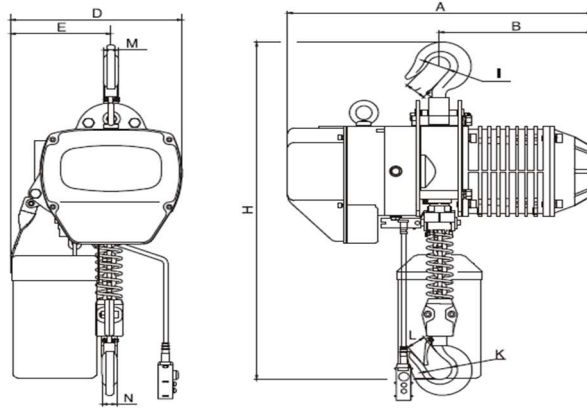

Hook Mounted Hoist Dimensions (in inches)

Cap. (Ton)	Model Number	H	A	B	K	L	N	I	Chain Dimension (mm)
1/4	NECHH-00526-†	21.3	17.9	9.4	φ 1.34	.98	0.75	φ 1.34	6.3
1/2	NECHH-01026-†	21.3	17.9	9.4	φ 1.34	.98	0.75	φ 1.34	6.3
1	NECHH-02013-†	22.6	17.9	9.4	φ 1.34	.98	0.75	φ 1.34	6.3
1/2	NECHH-01016-†	25.6	20.5	10.2	φ 1.65	1.25	0.94	φ 1.65	7.1
1	NECHH-02016-†	25.6	20.5	10.2	φ 1.65	1.25	0.94	φ 1.65	7.1
2	NECHH-04008-†	32.9	20.5	10.2	φ 1.93	1.57	1.18	φ 1.93	7.1
3	NECHH-06005-†	36.2	20.5	10.2	φ 2.32	1.88	1.37	φ 2.32	7.1
1	NECHH-02026-†	25.6	20.5	10.2	φ 1.65	1.25	0.94	φ 1.65	7.1
2	NECHH-04013-†	32.9	20.5	10.2	φ 1.93	1.57	1.18	φ 1.93	7.1
2	NECHH-04026-†	31.5	24.2	11.6	φ 1.93	1.57	1.18	φ 1.93	10
3	NECHH-06009-†	37.4	20.5	10.2	φ 2.32	1.88	1.37	φ 2.32	7.1
3	NECHH-06017-†	37.4	24.2	11.6	φ 2.32	1.88	1.37	φ 2.32	10
5	NECHH-10010-†	40.6	24.2	11.6	φ 2.36	1.88	1.69	φ 2.36	11.2
7.5	NECHH-15007-†	40.6	24.2	11.6	φ 3.31	3.11	2.20	φ 3.33	11.2

Cap. (Ton)	Model Number	Hoist Weight 10 ft lift (lb)
1/4	NECHH-00526-†	104
1/2	NECHH-01026-†	104
1	NECHH-02013-†	110
1/2	NECHH-01016-†	139
1	NECHH-02016-†	139
2	NECHH-04008-†	159
3	NECHH-06005-†	221
1	NECHH-02026-†	150
2	NECHH-04013-†	154
2	NECHH-04026-†	263
3	NECHH-06009-†	216
3	NECHH-06017-†	320
5	NECHH-10010-†	337
7.5	NECHH-15007-†	528

Hook Mounted Hoist Dimensions (in millimeters)

Cap. (Ton)	Model Number	H	A	B	K	L	N	I	Chain Dimension (mm)
1/4	NECHH-00526-†	540	455	240	φ 34	25	19	φ 34	6.3
1/2	NECHH-01026-†	540	455	240	φ 34	25	19	φ 34	6.3
1	NECHH-02013-†	575	455	240	φ 34	25	19	φ 34	6.3
1/2	NECHH-01016-†	650	520	260	φ 42	32	24	φ 42	7.1
1	NECHH-02016-†	650	520	260	φ 42	32	24	φ 42	7.1
2	NECHH-04008-†	835	520	260	φ 49	40	30	φ 49	7.1
3	NECHH-06005-†	950	520	260	φ 59	48	35	φ 59	7.1
1	NECHH-02026-†	650	520	260	φ 42	32	24	φ 42	7.1
2	NECHH-04013-†	835	520	260	φ 49	40	30	φ 49	7.1
2	NECHH-04026-†	800	615	295	φ 49	40	30	φ 49	10
3	NECHH-06009-†	950	520	260	φ 59	48	35	φ 59	7.1
3	NECHH-06017-†	950	615	295	φ 59	48	35	φ 59	10
5	NECHH-10010-†	1030	615	295	φ 60	48	43	φ 60	11.2
7.5	NECHH-15007-†	1030	615	295	φ 84	79	56	φ 84	11.2

Cap. (Ton)	Model Number	Hoist Weight 10 ft lift (lb)
1/4	NECHH-00526-†	104
1/2	NECHH-01026-†	104
1	NECHH-02013-†	110
1/2	NECHH-01016-†	139
1	NECHH-02016-†	139
2	NECHH-04008-†	159
3	NECHH-06005-†	221
1	NECHH-02026-†	150
2	NECHH-04013-†	154
2	NECHH-04026-†	263
3	NECHH-06009-†	216
3	NECHH-06017-†	320
5	NECHH-10010-†	337
7.5	NECHH-15007-†	528

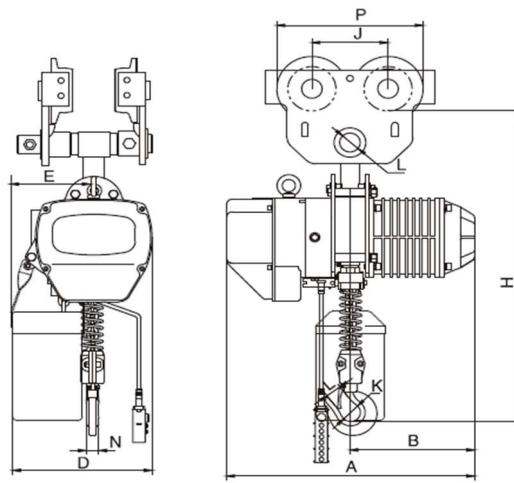

Hoist with Push Trolley Dimensions (in inches)

Cap. (Ton)	Model Number	H	A	B	K	L	N	I	J	Flange Width
1/4	NECHP-00526-†	21.9	17.9	9.4	φ 1.34	1.10	0.75	φ 1.02	3.5	2-6
1/2	NECHP-01026-†	21.9	17.9	9.4	φ 1.34	1.10	0.75	φ 1.02	3.5	2-6
1	NECHP-02013-†	24.8	17.9	9.4	φ 1.65	1.26	0.94	φ 1.02	4.5	2.5-8
1	NECHP-02026-†	25	20.5	10.2	φ 1.65	1.26	0.94	φ 1.65	4.5	2.5-8
2	NECHP-04013-†	31.5	20.5	10.2	φ 1.93	1.57	1.18	φ 1.93	5.5	3.5-8
2	NECHP-04026-†	30.1	24.2	11.6	φ 1.93	1.57	1.18	φ 1.93	5.5	3.5-8
3	NECHP-06009-†	38.1	20.5	10.2	φ 2.32	1.89	1.38	φ 1.42	4.5	4-12
3	NECHP-06017-†	37.8	24.2	11.6	φ 2.32	1.89	1.38	φ 2.32	4.5	4-12
5	NECHP-10010-†	39.6	24.2	11.6	φ 2.36	1.89	1.69	φ 1.69	6.5	4.5-12
7.5	NECHP-15007-†	43	24.2	11.6	φ 3.3	3.1	2.2	φ 3.3	1.2	4.9-12

Cap. (Ton)	Model Number	Flange Width	Hoist & Trolley Weight 10 ft lift (lb)
1/4	NECHP-00526-†	2-6	120
1/2	NECHP-01026-†	2-6	122
1	NECHP-02013-†	2.5-8	138
1	NECHP-02026-†	2.5-8	177
2	NECHP-04013-†	3.5-8	204
2	NECHP-04026-†	3.5-8	310
3	NECHP-06009-†	4-12	264
3	NECHP-06017-†	4-12	388
5	NECHP-10010-†	4.5-12	432
7.5	NECHP-15007-†	4.9-12	733

Hoist with Push Trolley Dimensions (in millimeters)

Cap. (Ton)	Model Number	H	A	B	K	L	N	I	J	Flange Width
1/4	NECHP-00526-†	555	455	240	φ 34	28	19	φ 26	89	2-6
1/2	NECHP-01026-†	555	455	240	φ 34	28	19	φ 26	89	2-6
1	NECHP-02013-†	630	455	240	φ 42	32	24	φ 26	115	2.5-8
1	NECHP-02026-†	635	520	260	φ 42	32	24	φ 26	115	2.5-8
2	NECHP-04013-†	800	520	260	φ 49	40	30	φ 31	138	3.5-8
2	NECHP-04026-†	764	615	295	φ 49	40	30	φ 31	138	3.5-8
3	NECHP-06009-†	968	520	260	φ 59	48	35	φ 36	115	4-12
3	NECHP-06017-†	960	615	295	φ 59	48	35	φ 36	115	4-12
5	NECHP-10010-†	969	520	260	φ 59	48	35	φ 36	165	4.5-12
7.5	NECHP-15007-†	1092	615	294	φ 84	78	56	φ 84	30	4.9-12

Cap. (Ton)	Model Number	Flange Width	Hoist & Trolley Weight 10 ft lift (lb)
1/4	NECHP-00526-†	51-152	120
1/2	NECHP-01026-†	51-152	122
1	NECHP-02013-†	64-203	138
1	NECHP-02026-†	64-203	177
2	NECHP-04013-†	89-203	204
2	NECHP-04026-†	89-203	310
3	NECHP-06009-†	102-305	264
3	NECHP-06017-†	102-305	388
5	NECHP-10010-†	114-305	432
7.5	NECHP-15007-†	114-305	733

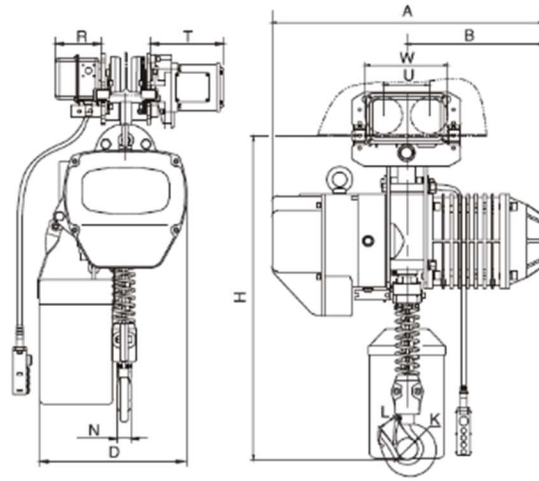

Hoist with Motorized Trolley Dimensions (in inches)

Cap. (Ton)	Model Number	H	A	B	D	I	K	L	N	T	Flange Width
1/4	NECHM-0526-†	24.0	17.9	9.1	11.2	φ 1.22	φ 1.33	0.98	0.75	9.1	2.3-13
1/2	NECHM-01026-†	24.0	17.9	9.1	11.2	φ 1.22	φ 1.33	0.98	0.75	9.1	2.3-13
1	NECHM-02013-†	26.2	17.9	9.1	11.2	φ 1.22	φ 1.65	1.26	0.94	9.1	2.3-13
1/2	NECHM-01016-†	25.6	20.5	10.2	11.8	φ 1.22	φ 1.65	1.26	0.94	9.1	2.3-13
1	NECHM-02016-†	25.6	20.5	10.2	11.8	φ 1.22	φ 1.65	1.26	0.94	9.1	2.3-13
2	NECHM-04008-†	32.1	20.5	10.2	11.8	φ 1.42	φ 1.93	1.57	1.18	9.1	3.2-13
3	NECHM-06005-†	37.0	20.5	10.2	11.8	φ 1.69	φ 2.32	1.89	1.38	9.1	3.9-13
1	NECHM-02026-†	25.6	20.5	10.2	11.8	φ 1.22	φ 1.65	1.26	0.94	9.1	2.3-13
2	NECHM-04013-†	32.1	20.5	10.2	11.8	φ 1.22	φ 1.93	1.58	1.18	9.1	3.2-13
2	NECHM-04026-†	30.3	24.2	11.6	16.9	φ 1.42	φ 1.93	1.58	1.18	9.1	3.2-13
3	NECHM-06009-†	37.0	20.5	10.2	13.8	φ 1.69	φ 2.32	1.89	1.38	9.1	3.9-13
3	NECHM-06017-†	36.6	24.2	11.6	16.9	φ 1.69	φ 2.32	1.89	1.38	9.1	3.9-13
5	NECHM-10010-†	40.0	20.5	10.2	13.8	φ 2.13	φ 2.36	1.89	6	9.1	3.9-13
7.5	NECHM-15007-†	43.0	24.2	11.6	16.9	φ 2.73	φ 2.96	1.89	6	9.1	3.9-13

Cap. (Ton)	Model Number	Flange Width (in)	Hoist & Trolley Weight 10 ft lift (lb)
1/4	NECHM-00526-†	2.3-13	197
1/2	NECHM-01026-†	2.3-13	197
1	NECHM-02013-†	2.3-13	204
1/2	NECHM-01016-†	2.3-13	232
1	NECHM-02016-†	2.3-13	232
2	NECHM-04008-†	3.2-13	266
3	NECHM-06005-†	3.9-13	350
1	NECHM-02026-†	2.3-13	243
2	NECHM-04013-†	3.2-13	261
2	NECHM-04026-†	3.2-13	369
3	NECHM-06009-†	3.9-13	345
3	NECHM-06017-†	3.9-13	448
5	NECHM-10010-†	3.9-13	426
7.5	NECHM-15007-†	3.9-13	620

Hoist with Motorized Trolley Dimensions (in millimeters)

Cap. (Ton)	Model Number	H	A	B	D	I	K	L	N	T	Flange Width Range
1/4	NECHM-00526-†	610	455	240	285	φ 31	φ 34	25	19	231	58-330
1/2	NECHM-01026-†	610	455	240	285	φ 31	φ 34	25	19	231	58-330
1	NECHM-02013-†	655	455	240	285	φ 31	φ 42	32	24	231	58-330
1/2	NECHM-01016-†	650	520	260	300	φ 31	φ 42	32	24	231	58-330
1	NECHM-02016-†	650	520	260	300	φ 31	φ 42	32	24	231	58-330
2	NECHM-04008-†	815	520	260	300	φ 36	φ 49	40	30	231	82-330
3	NECHM-06005-†	940	520	260	300	φ 43	φ 59	48	35	231	100-330
1	NECHM-02026-†	650	520	260	300	φ 31	φ 42	32	24	231	58-330
2	NECHM-04013-†	815	520	260	300	φ 36	φ 49	40	30	231	82-330
2	NECHM-04026-†	770	615	295	430	φ 36	φ 49	40	30	231	82-330
3	NECHM-06009-†	940	520	260	350	φ 43	φ 59	48	35	231	100-330
3	NECHM-06017-†	930	615	295	430	φ 43	φ 59	48	35	231	100-330
5	NECHM-10010-†	1015	615	295	430	φ 54	φ 60	48	43	231	100-330
7.5	NECHM-15007-†	43	24.2	11.6	16.9	φ 3.3	φ 1.2	11.7	6	231	100-330

Cap. (Ton)	Model Number	Flange Width (mm)	Hoist & Trolley Weight 10 ft lift (lb)
1/4	NECHM-00526-†	58-330	197
1/2	NECHM-01026-†	58-330	197
1	NECHM-02013-†	58-330	204
1/2	NECHM-01016-†	58-330	232
1	NECHM-02016-†	58-330	232
2	NECHM-04008-†	82-330	266
3	NECHM-06005-†	100-330	350
1	NECHM-02026-†	58-330	243
2	NECHM-04013-†	82-330	261
2	NECHM-04026-†	82-330	369
3	NECHM-06009-†	100-330	345
3	NECHM-06017-†	100-330	448
5	NECHM-10010-†	100-330	426
7.5	NECHM-15007-†	100-330	620

Hoist Dimensions

10 Ton Hoist – Hook Mounted

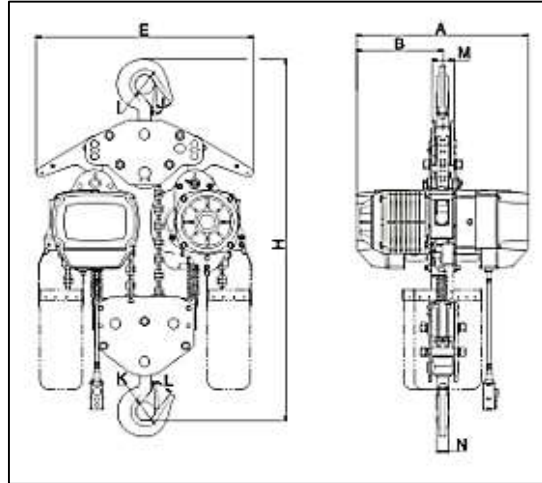

Hoist Dimensions

Cap. (Ton)	Model Number	H	A	B	E	I	J	K	L	M	N
10	NECHH-20010- †	51.6	24.8	12.4	35	φ 3.3	3.1	φ 3.3	3.1	4.1	2.2

10 Ton Hoist with Motorized Trolley

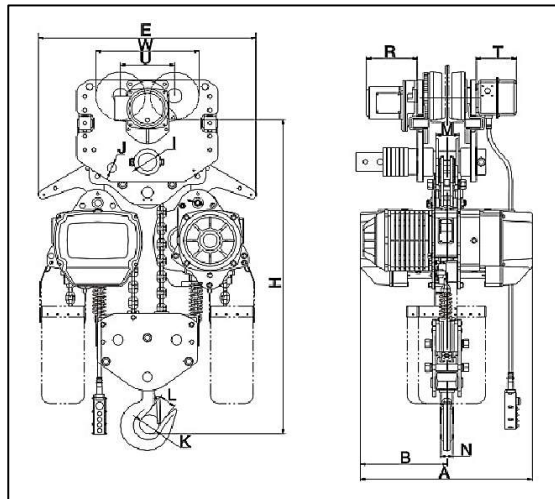

Hoist Dimensions

Cap. (Ton)	Model Number	H	A	B	E	I	J	K	L	M	N	W	U	R	T
10	NECHM-20011- †	43.4	24.8	12.4	35	φ2.8	φ1.4	φ3.35	3.1	3.3	2.2	14.4	7.5	9.1	5.6

15 – 25 Ton Hoists with Motorized Trolley

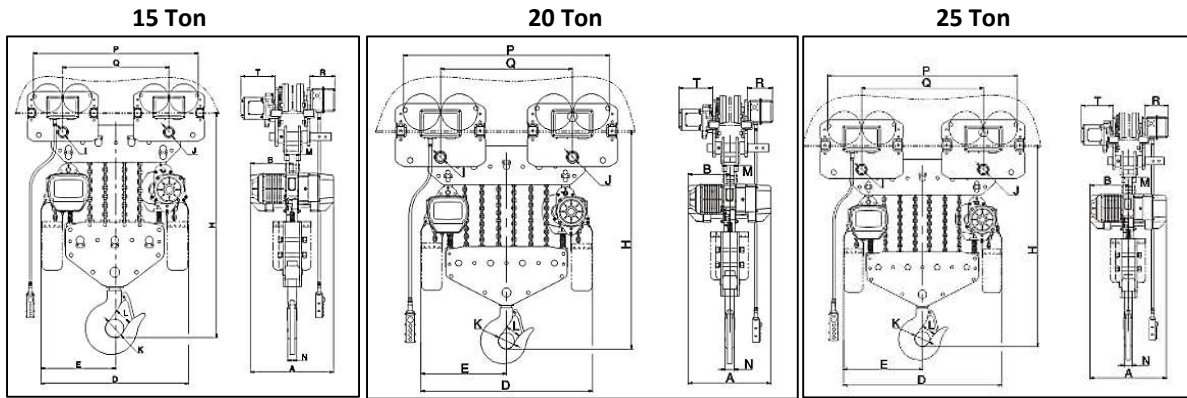

Hoist Dimensions

Cap. (Ton)	Model Number	H	A	B	D	E	I	J	K	L	M	N	P	Q	R	T
15	NECHM-30007-†	48.1	24.8	12.4	42.1	21.1	φ2.1	φ2.1	φ4.7	3.8	3.5	3.1	36.5	22	5.6	9.1
20	NECHM-40005-†	54.4	24.8	12.4	49.6	24.8	φ2.8	φ2.8	φ5.9	4.5	3.5	3.7	43.5	29	5.6	9.1
25	NECHM-50005-†	54.4	24.8	12.4	49.6	24.8	φ2.8	φ2.8	φ5.9	4.5	3.5	3.7	43.5	29	5.6	9.1

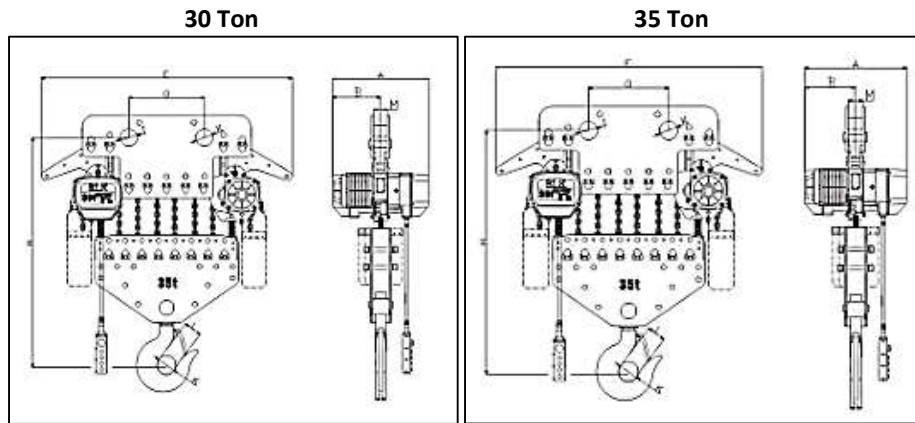

Hoist Dimensions

Cap. (Ton)	Model Number	H	A	B	E	I	J	K	L	M	N
30	NECHM-60003-†	61.1	24.8	12.4	59.4	φ3.9	φ3.9	φ7.7	5.5	7.3	5.5
35	NECHM-70003-†	61.1	24.8	12.4	59.4	φ3.9	φ3.9	φ7.7	5.5	7.3	5.5