

Electric Chain Hoist (Single Phase)



Specifications

Model Number	Capacity (Ton)	Lift Speed (Ft/Min)	Number of Chain Falls	Hoist Motor 1 Phase / 60 Hz					
				HP	Rated Current				
					230 V				
SECHH-00518	1/4	18	1	1.3	11				
SECHH-00526		26							
SECHH-00544		44							
SECHH-01018	1/2	18		1	1.3	11			
SECHH-01026		26							
SECHH-01044		44							
SECHH-02018	1	18			1		1.3	11	
SECHH-02026		26							
SECHH-04026		26							
SECHH-04009	2	9	2				1.3		11
SECHH-04013		13							
SECHH-06017		17							
SECHH-06006	3	6	3	1.3		11			
SECHH-06009		9							
SECHH-10010	5	10	2	5.0		30			
SECHH-15007	7 1/2	7							
SECHH-20010	10	10	4	2 X 5.0	2 X 30				
SECHH-30007	15	7							
SECHH-40005	20	5	8	2 X 5.0					

Electric Chain Hoist (Single Phase)



Low Headroom Motorized Trolley Specifications

Model Number	Capacity (Tons)	Number of Chain Falls	Trolley Motor			
			50 FPM		100 FPM	
			HP	Rated Current	HP	Rated Current
				230V		230V
MT-020-1	1/4	1	0.5	5.5	0.5	5.5
MT-020-1	1/2					
MT-020-1	1					
MT-040-2	2	2	1	9	1	9
MT-040-1		1				
MT-060-3	3	3	1	9	1	9
MT-060-2		2				
MT-100-2	5	2				

Standard Motorized Trolley Specifications

Model Number	Capacity (Tons)	Number of Chain Falls	Trolley Motor			
			50 FPM		100 FPM	
			HP	Rated Current	HP	Rated Current
				230V		230V
MT-150-3	7 1/2	3	1	9	1	9
MT-200-4	10	4	2 X 1	2 X 9	2 X 1	2 X 9
2 X MT-150-3	15	6				
2 X MT-200-4	20	8	2 X 1	2 X 9	2 X 1	2 X 9

Electric Chain Hoist (Single Phase)

Dimensions

1/4 - 7 1/2 Ton Electric Chain Hoist Hook Mounted Dimensions

Model Number	H*	D	E*	F	G	I	J*	K	L	O	Approx. Gross Weight w/out Chains (Lbs.)	Single Speed						Variable Frequency Drive							
												A	B	C	G	M	P	T	A	B	C	G	M	P	T
												SECHH-00518	20	11.8	7	4.8	6.3	1.4	11.2	0.9	1.3	---	138	21.75	10.7
SECHH-00526																									
SECHH-00544																									
SECHH-01018																									
SECHH-01026																									
SECHH-01044																									
SECHH-02018																									
SECHH-02026																									
SECHH-04026	28	16.3	10.25	6.1	7.5	1.6	14	1.23	1.59	---	280	25.5	12	13.5	---	---	---	---	29.75	12	17.75	---	---	---	---
SECHH-04009	27.6	12.5	9.4	3.2	8.6	1.6	11.2	1.22	1.5	---	155	21.5	10.5	11	---	---	---	---	25	10.5	14.5	---	---	---	---
SECHH-04013																									

Electric Chain Hoist (Single Phase)



Electric Chain Hoist (Single Phase)

1/4 - 5 Ton Electric Chain Hoist w/ Standard Push Trolley Dimensions

Model Number	H	Q	O	R	S	C	B	P
SECHP-00518	25	8	9.5	8	1.25	11	10.7	1.75 – 5.5
SECHP-00526								
SECHP-00544								
SECHP-01018	26.25	9.68	12.25	7.37	1.5	13.5	12	1.75 – 5.93
SECHP-01026								
SECHP-01044								
SECHP-02018	32.7	10.87	12.87	10.35	1.62	11	10.7	2.75 - 8
SECHP-02026								
SECHP-04009								
SECHP-04013	33.1	13.07	13.5	13	1.62	13.5	12	3.5 - 8
SECHP-04026								
SECHP-06006								
SECHP-06009	39	13.07	13.5	13	1.62	11	10.7	3.93 - 8
SECHP-06017								
SECHP-10010								
SECHP-10010	42.5	14.87	14	13.86	1.62	13.5	12	4.5 - 5
SECHP-10010	45.36							

All dimensions measured in inches.
Based on 10ft of lift.

Electric Chain Hoist (Single Phase)

1/4 - 5 Ton Electric Chain Hoist w/ Low Headroom Push Trolley Dimensions

Model Number	H	Q	O	R	S	C	B	P
SECHP-00518	16.5	4.2	0.5	0.5	16.5	11	10.7	3 - 10
SECHP-00526								
SECHP-00544								
SECHP-01018								
SECHP-01026								
SECHP-01044								
SECHP-02018	22				17.3		10.5	
SECHP-02026								
SECHP-04009	24				20	13.5	12	3.75 - 13
SECHP-04013								
SECHP-04026	23				20.7	11	10.7	4 - 10
SECHP-06006								
SECHP-06009	29.75	4.9	0.6	0.6	20	13.5	12	3.75 - 13
SECHP-06017								
SECHP-10010	30.75	5.5			20.5			3.75 - 12.5

All dimensions measured in inches.
Based on 10 ft of lift.

Electric Chain Hoist (Single Phase)

Hoist with Motor Trolley Dimensions

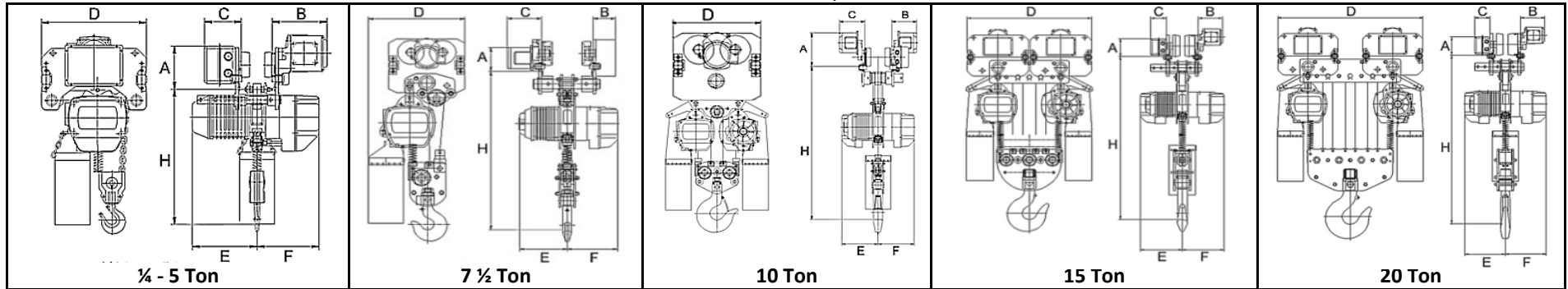

Model Number	H	A	B	C	D	E	F	Flange Width Range	Approx. Gross Weight (Lbs.)		
SECHM-00518	16.5	8	8.5	7.75	16.5	10.5	11	3 - 9.5	303.6		
SECHM-00526											
SECHM-00544											
SECHM-01018					17.5	12	13.5			4 - 12.5	528.5
SECHM-01026											
SECHM-01044											
SECHM-02018	23	8	8.5	20.75	10.75	11	5 - 10	477.8			
SECHM-02026											
SECHM-04009	24	10	8.75	8	20	12	13.5	4 - 12.5	593.5		
SECHM-04013											
SECHM-04026	29.75	11	8.75	8	20.5	12	13.5	4 - 12.5	652.5		
SECHM-06006											
SECHM-06009	30.75	8	8	6.75	39	49.25	6 - 12	826.5			
SECHM-06017											
SECHM-10010	43	7	8	6.75	39	49.25	6 - 12	1408.5			
SECHM-15007											
SECHM-20010	45	7	8	6.75	39	49.25	6 - 12	1716.5			
SECHM-30007											
SECHM-40005	45	7	8	6.75	49.25	12	13.5	6 - 12	2773.5		

* Can change to 3.75" specification modification.
All measurements are in inches.

Electric Chain Hoist (Single Phase)



Based on 10 ft of lift.