

DIMENSIONS

500 SERIES : Model 5008

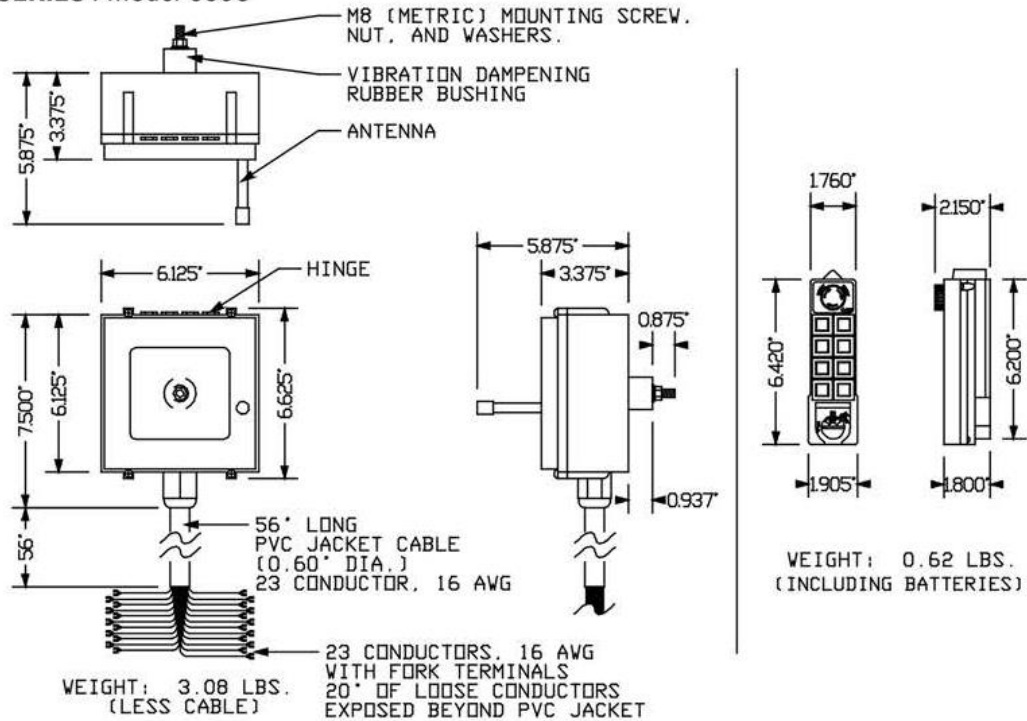

500 SERIES : Model 50011

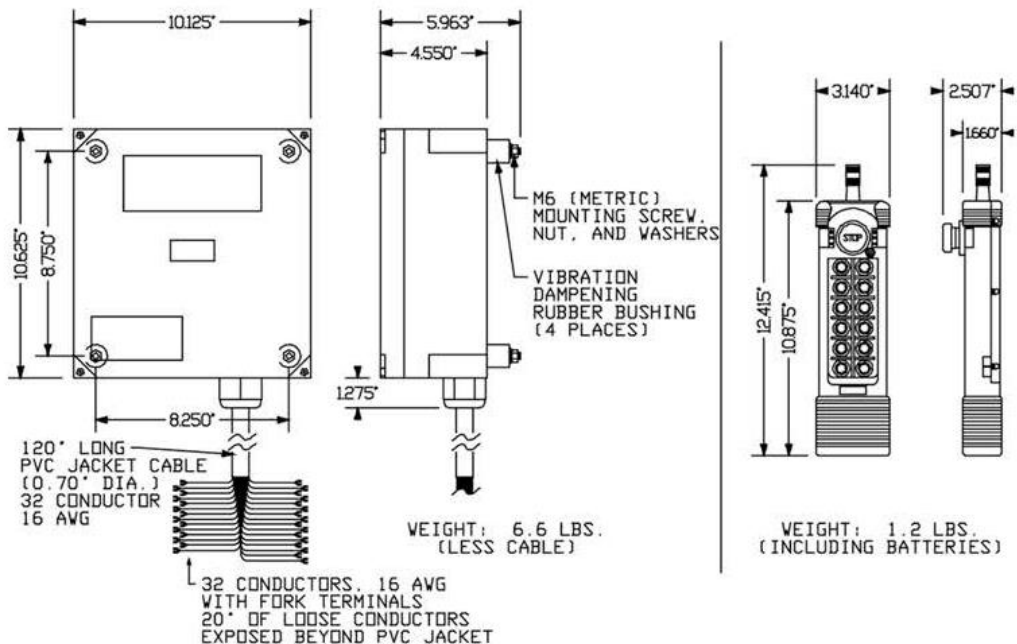

SPECIFICATIONS

500 Series has unique and outstanding features and is fully programmable. Best use: Overhead Crane and most Heavy Loading Equipment.

The 500 Series Model 5008 is a 2-speed transmitter with eight buttons for control of 3-4 motions. FCC 310-320 Mhz AC models only. Each kit includes receiver, one or two transmitters, four batteries, strap, legend sheet for each transmitter, spare key, spare fuse kit, and instruction manual. This radio has programmable operation.

The 500 Series Model 50011 is a 2-speed transmitter with eleven buttons for control of up to 5 motions. FCC 310-320 Mhz AC models only. Each kit includes receiver, one or two transmitters, four batteries, strap, legend sheet for each transmitter, spare key, spare fuse kit, and instruction manual. This radio has programmable operation.

5008: 8 double-step pushbuttons + Start + EMS

50011: 11 double-step pushbuttons + Start + EMS



500 Series Transmitter

500 Series Receiver

500 Series Transmitter

500 Series Receiver

Transmitter Specifications:

5008

L X W X H: 6.42" X 1.93" X 1.77" (163 X 49 X 45 mm)

Weight: 0.61 lbs. {0.3 kg} *with batteries

Two (2) AA size batteries

50011

L X W X H: 10.79" X 3.03" X 1.65" (274 X 77 X 42 mm)

Weight: 1.19 lbs. (0.5 kg) *with batteries

Four (4) AA size batteries

General Specifications:

Frequency Control: Crystal

Low Power Indicator

Pushbutton Jammed Detector

Operation Range: Up to -328 feet (100 meters)

Operating Temperature: -49°F ~ 176°F (-45°C ~ +80°C)

Power Consumption: about 10mW

Structure: Nylon and Glass Fiber

Shock Resistant

Function Programmable

Receiver Specifications:

5008

L X W X H: 6.58" X 6.06" X 3.47" {167 X 154 X 88 mm}

Weight: 3.09 lbs. {1.4 kg} *without cable

Input Voltage: AC Type: 24/48/110/220/380V;

DC Type: 12~24V

50011

L X W X H: 9.96" X 10.51" X 5.91" (253 X 267 X 150 mm)

Weight: 6.61 lbs. {3.0 kg} *without cable

Input Voltage: AC Type: 24/48/110/220/380V;

DC Type: 12~24V