

DIMENSIONS

200 Series Receiver Weight: 2.4 lb (1.1 kg) - *Without Cable*

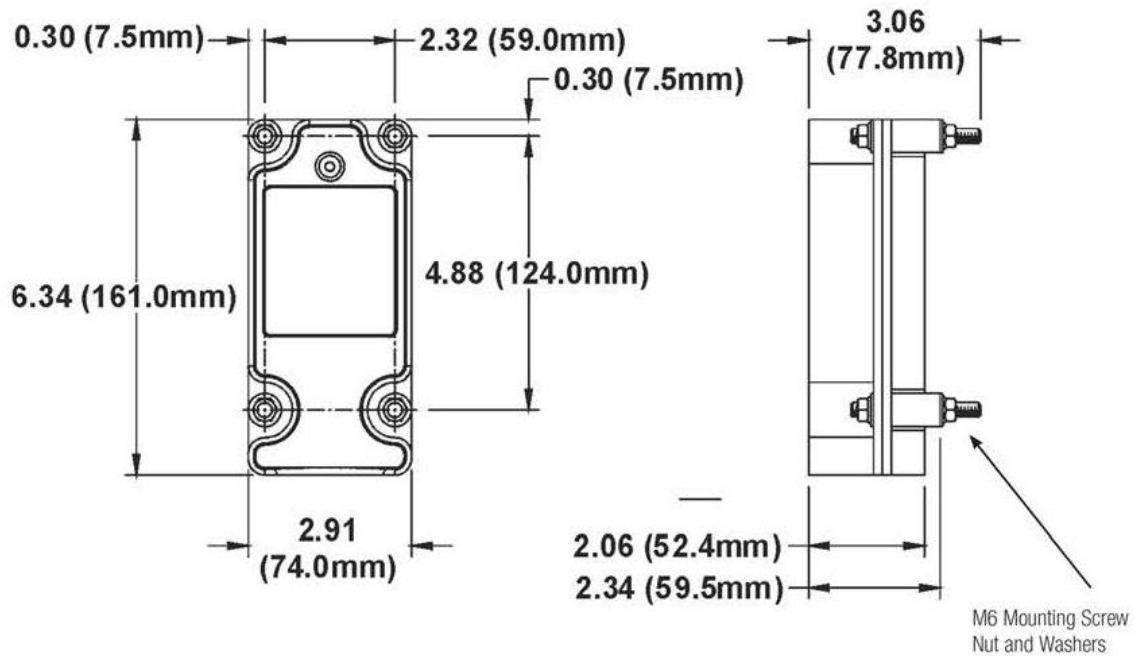

200 Series Transmitter Weight: 0.34 lb (0.2 kg) - *Including Batteries*

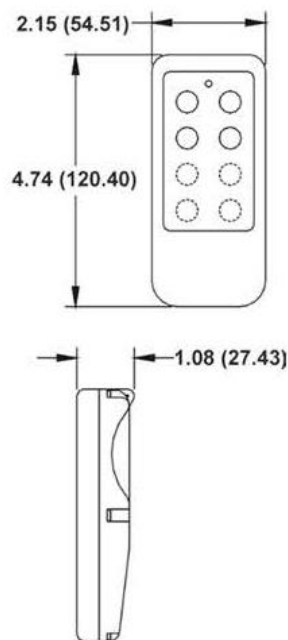

SPECIFICATIONS

200 Series Remote Control transmitters are available in 2, 4, & 6 button single-speed configurations. A small compact pocket-size transmitter; fully safety-compliant, simple installation, suitable for SUV,

Winch, Conveyor, Boat Lifting Equipment, Greenhouse Spreader, etc. The major application will be the vehicle market, especially for tow trucks.

2002: 2 single-step pushbuttons (Start, Stop, Up, Down)



200 Series Transmitter



200 Series Receiver

2004: 4 single-step pushbuttons (Start, Stop, Up, Down, East, West)



200 Series Transmitter



200 Series Receiver

2006: 6 single-step pushbuttons (Start, Stop, Up, Down, North, South, East, West)



200 Series Transmitter



200 Series Receiver

General Specifications:

Frequency Control: Crystal
Low Power Indicator
Pushbutton Jammed Detector
Operation Range: Up to ~328 feet (100 meters)
Operating Temperature: -49°F ~ 176°F (-45°C ~ +80°C)
Power Consumption: about 10mW
Structure: Nylon and Glass Fiber
Shock Resistant
Function Programmable

Transmitter Specifications:

L x W x H: 4.72" X 2.17" X 0.98" {120 X 55 X 25 mm}
Weight: 0.34 lbs. (0.2 kg) *with batteries
Two {2} AA size batteries

Receiver Specifications:

L x W x H: 6.34" X 2.91" X 2.05" {161 X 74 X 52 mm}
Weight: 2.43 lbs. (1.1 kg) *without cable
Input Voltage: AC Type: 24/48/110/220/380V;
DC Type: 12~24V