



Features

- Capacity range from ¼ to 1 ton.
- 115v single phase power (115 V / 60 Hz) for plug-in convenience.
- Lightweight, robust construction.
- H3 duty rating.
- Dual braking systems – mechanical & regenerative.
- Easy to install and maintain.
- Fully forged hooks are fitted with hook safety latches as standard.
- Baked finish gives the frame superior resistance to harmful environments.
- Each hoist is tested at 1.5 times maximum weight rating.

Mechanics Hoist Construction

The ACI Mechanics Hoist is an efficient means of lifting freely suspended material loads within its load rating. The frame and covers of the hoist are made from aluminum alloy or cast iron components to ensure structural integrity. The compact design features very low headroom, allowing operation in tight quarters.

Benefits and Features

1. Load Sheave – Deep-groove pockets fully support the load chain. Sheave provides smoother lifting, reduces vibration and reduces chain wear.
2. Friction Clutch – A high performance and long life friction clutch that is integrated with the load brake. The Friction Clutch is designed to slip in order to prevent over loading and over travel that could damage the hoist.
3. Chain End Stop Assembly – For added protection the chain end stop assembly fits below the end link of the lifting chain.
4. Heat Treated Gearing – The gears are machined for a longer life span. The ball or needle bearings at all rotating points run in oil bath lubrication for quieter, smoother and cooler operation.
5. Chain Guide – Heavy cast iron construction for improved wear resistance. The chain guide provides a quieter and smoother guiding of the chain. The chain guide is easy to remove without disassembling the hoist and features easy capacity conversion.
6. Compact Design – The die-cast body offers low head room to fit into tight areas and is class F insulated for longer life and trouble-free service.
7. Hoist Motor – The horse power and top duty ratings provide increased performance for industrial situations. The compact DC motor (with rectifier for AC input) reduces weight, generates less heat and maintains duty cycles.
8. Load Chain- Grade 80 superior quality load chain is heat treated for wear resistance, long extended life and dependable service.
9. Control Panel – Easy maintenance, simple layout of the controls, fast access.
10. Chain Container – A vinyl chain container is provided standard with the Mechanics Hoist.

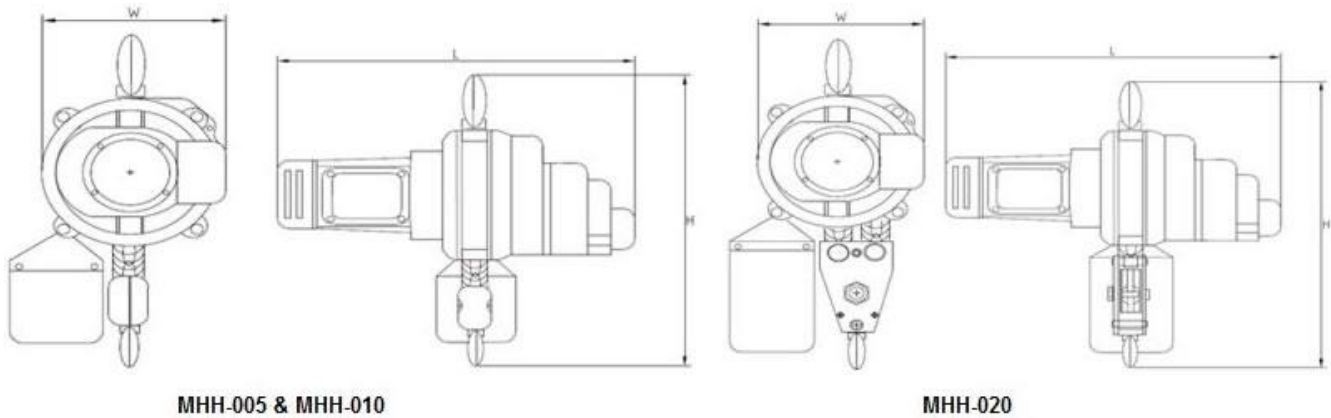

Mechanics Hoist

Mechanics Hoist Specifications (Table 1)

Capacity (Ton)	Model Number	Standard Lift (ft)	Standard Pendant Drop (ft)	Lift Speed (ft/min)	No. of Chain Falls	Hoist Motor		W Width (in)	L Length (in)	H Headroom (in)
						HP	@110-120V (amps)			
¼	MHH-005	10	10	16	1	1.8	16.5	6.3	16.5	18.9
½	MHH-010			16	1	1.8	16.5	6.3	16.5	18.9
1	MHH-020			8	2	1.8	16.5	6.3	16.5	19.7

Mechanics Hoists

WARRANTY

Every hoist is thoroughly inspected and tested prior to shipment from the factory.

All products sold by ACI Hoist & Crane, Inc. are warranted to be free from defects in material and workmanship from date of shipment by ACI for a period of one (1) year.

The product must be used in accordance with manufacturer's recommendations and must not have been subject to abuse, lack of maintenance, misuse, negligence, or unauthorized repairs or alterations conducted by non-ACI Factory Authorized personnel.

Should any defect in material or workmanship occur during the above time period in any product, as determined by ACI's Inspection of the product, ACI agrees, at its discretion, either to replace (not including installation) or repair the part or product free of charge and deliver said item F.O.B. ACI's place of business to the customer.

Customer must contact ACI to obtain a Return Authorization prior to shipping product for warranty evaluation. And explanation of the complaint must accompany the product. Product must be returned freight prepaid. Upon repair, the product will be covered for the remainder of the original warranty period. If it is determined there is no defect or that the defect resulted from causes not within the scope of ACI's warranty, the customer will be responsible for the costs of returning the product.

ACI Hoist & Crane, Inc. disclaims any and all other warranties of any kind expressed or implied as to the product's merchantability or fitness for a particular application. ACI will not be liable for death, injuries to persons or property or for incidental, contingent, special or consequential damages, loss or expense arising in connection with the use or inability whatever, regardless of whether damages, loss or expense arising in connection with the use or inability whatever, regardless of whether damage, loss or expense results from any act or failure to act by ACI, whether negligent or willful, or for any other reason.

WARNING

Overloading and Improper Use Can Result in Injury.

To Avoid Injury:

- Do not exceed working load limit, load rating, or capacity.
- Do not use to lift people or loads over people.
- Use only alloy chain and attachments for overhead lifting.
- Read and follow all instructions.