

## Hoist Specifications

Capacity (Ton)	Model Number	No. of Chain Falls	Lift Speed (FPM)	HP	Rated Current		Weight (Lb)
					230 V (Amp)	460 V (Amp)	
1/4	NECH*-00526	1	26	1.0	3.2	1.6	112
1/2	NECH*-01016	1	16	1.5	3.2	1.6	101
1/2	NECH*-01026	1	26	1.0	3.2	1.6	112
1	NECH*-02013	2	13	1.0	3.2	1.6	112
1	NECH*-02016	1	16	1.5	4.2	2.1	121
1	NECH*-02026	1	26	2.0	6.5	3.2	121
2	NECH*-04008	2	8	1.5	4.2	2.1	152
2	NECH*-04013	2	13	2.0	6.5	3.2	152
2	NECH*-04026	1	26	4.0	13	6.5	236
3	NECH*-06006	3	6	1.5	4.2	2.1	174
3	NECH*-06009	3	9	2.0	6.5	3.2	174
3	NECH*-06017	2	17	4.0	13	6.5	282
5	NECH*-10010	2	10	4.0	13	6.5	287
7.5	NECH*-15007	3	7	4.0	13	6.5	311
10	NECH*-20010	4	10	2 x 4.0	2 x 13	2 x 6.5	619
15	NECH*-30007	6	7	2 x 4.0	2 x 13	2 x 6.5	842
20	NECH*-40005	8	5	2 x 4.0	2 x 13	2 x 6.5	1025
25	NECH*-50005	8	5	2 x 4.0	2 x 13	2 x 6.5	1069
30	NECH*-60003	10	3	2 x 4.0	2 x 13	2 x 6.5	2116
35	NECH*-70003	10	3	2 x 4.0	2 x 13	2 x 6.5	2535

To complete your Model Number insert the following in place of asterisks:

- \* Suspension Type:
  - H = Hook Mounted
  - L = Lug Mounted
  - M = With Motorized Trolley
  - P = With Push Trolley
  - G = With Geared Trolley

† Lift, in feet



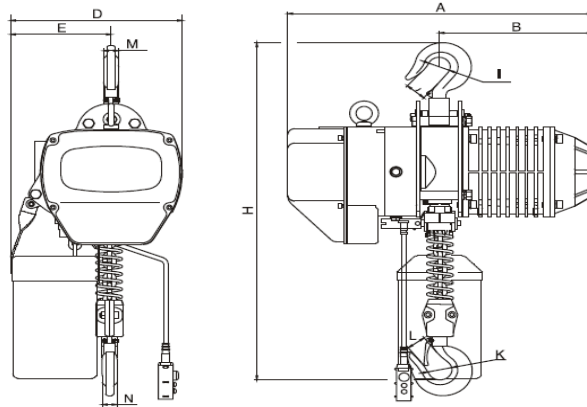

### Hook Mounted Hoist Dimensions (in inches)

Cap. (Ton)	Model Number	H	A	B	K	L	N	I	Chain Dimension (mm)
1/4	NECHH-00526-†	21.25	17.9	9.4	φ 1.34	.98	0.75	φ 1.34	6.3
1/2	NECHH-01026-†	21.25	17.9	9.4	φ 1.34	.98	0.75	φ 1.34	6.3
1	NECHH-02013-†	22.6	17.9	9.4	φ 1.34	.98	0.75	φ 1.34	6.3
1	NECHH-02026-†	25.6	20.5	10.2	φ 1.65	1.25	0.94	φ 1.65	7.1
2	NECHH-04013-†	32.9	20.5	10.2	φ 1.93	1.57	1.18	φ 1.93	7.1
2	NECHH-04026-†	31.5	24.2	11.6	φ 1.93	1.57	1.18	φ 1.93	10
3	NECHH-06009-†	37.4	20.5	10.2	φ 2.32	1.88	1.37	φ 2.32	7.1
3	NECHH-06017-†	37.4	24.2	11.6	φ 2.32	1.88	1.37	φ 2.32	10
5	NECHH-10010-†	40.6	24.2	11.6	φ 2.36	1.88	1.69	φ 2.36	11.2
7.5	NECHH-15007-†	40.6	24.2	11.6	φ 3.3	3.1	2.2	φ 3.3	11.2

### Hook Mounted Hoist Dimensions (in millimeters)

Cap. (Ton)	Model Number	H	A	B	K	L	N	I	Chain Dimension (mm)
1/4	NECHH-00526-†	540	455	240	φ 34	25	19	φ 34	6.3
1/2	NECHH-01026-†	540	455	240	φ 34	25	19	φ 34	6.3
1	NECHH-02013-†	575	455	240	φ 34	25	19	φ 34	6.3
1	NECHH-02026-†	650	520	260	φ 42	32	24	φ 42	7.1
2	NECHH-04013-†	835	520	260	φ 49	40	30	φ 49	7.1
2	NECHH-04026-†	800	615	295	φ 49	40	30	φ 49	10
3	NECHH-06009-†	950	520	260	φ 59	48	35	φ 59	7.1
3	NECHH-06017-†	950	615	295	φ 59	48	35	φ 59	10
5	NECHH-10010-†	1030	615	295	φ 60	48	43	φ 60	11.2
7.5	NECHH-15007-†	1030	615	295	φ 8.3	79	56	φ 84	11.2

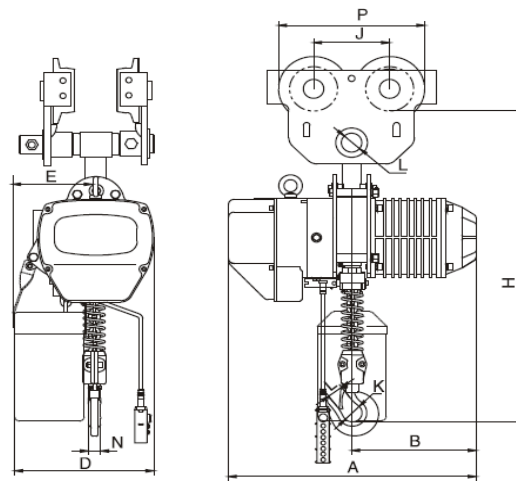

### Hoist with Push Trolley Dimensions (in inches)

Cap. (Ton)	Model Number	H	A	B	K	L	N	I	J	Flange Width
1/4	NECHP-00526-†	21.9	17.9	9.4	φ 1.34	1.10	0.75	φ 1.02	3.5	2-6
1/2	NECHP-01026-†	21.9	17.9	9.4	φ 1.34	1.10	0.75	φ 1.02	3.5	2-6
1	NECHP-02013-†	24.8	17.9	9.4	φ 1.65	1.26	0.94	φ 1.02	4.5	2.5-8
1	NECHP-02026-†	25	20.5	10.2	φ 1.65	1.26	0.94	φ 1.65	4.5	2.5-8
2	NECHP-04013-†	31.5	20.5	10.2	φ 1.93	1.57	1.18	φ 1.93	5.5	3.5-8
2	NECHP-04026-†	30.1	24.2	11.6	φ 1.93	1.57	1.18	φ 1.93	5.5	3.5-8
3	NECHP-06009-†	38.1	20.5	10.2	φ 2.32	1.89	1.38	φ 1.42	4.5	4-12
3	NECHP-06017-†	37.8	24.2	11.6	φ 2.32	1.89	1.38	φ 2.32	4.5	4-12
5	NECHP-10010-†	39.6	24.2	11.6	φ 2.36	1.89	1.69	φ 1.69	6.5	4.5-12
7.5	NECHP-15007-†	43	24.2	11.6	φ 3.3	3.1	2.2	φ 3.3	1.2	4.9-12

### Hoist with Push Trolley Dimensions (in millimeters)

Cap. (Ton)	Model Number	H	A	B	K	L	N	I	J	Flange Width
1/4	NECHP-00526-†	555	455	240	φ 34	28	19	φ 26	89	2-6
1/2	NECHP-01026-†	555	455	240	φ 34	28	19	φ 26	89	2-6
1	NECHP-02013-†	630	455	240	φ 42	32	24	φ 26	115	2.5-8
1	NECHP-02026-†	635	520	260	φ 42	32	24	φ 26	115	2.5-8
2	NECHP-04013-†	800	520	260	φ 49	40	30	φ 31	138	3.5-8
2	NECHP-04026-†	764	615	295	φ 49	40	30	φ 31	138	3.5-8
3	NECHP-06009-†	968	520	260	φ 59	48	35	φ 36	115	4-12
3	NECHP-06017-†	960	615	295	φ 59	48	35	φ 36	115	4-12
5	NECHP-10010-†	969	520	260	φ 59	48	35	φ 36	165	4.5-12
7.5	NECHP-15007-†	1092	615	294	φ 84	78	56	φ 84	30	4.9-12

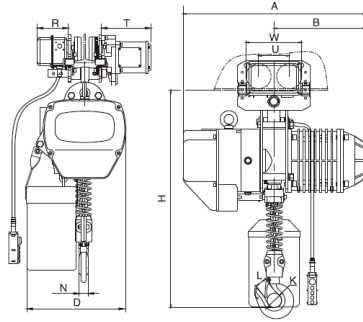

### Hoist with Motorized Trolley Dimensions (in inches)

Cap. (Ton)	Model Number	H	A	B	D	I	K	L	N	T	Flange Width
1/4	NECHM-00526-†	24	17.9	9.1	11.2	φ 1.22	φ 1.33	0.98	0.75	9.1	2.5-13
1/2	NECHM-01026-†	24	17.9	9.1	11.2	φ 1.22	φ 1.33	0.98	0.75	9.1	2.5-13
1	NECHM-02013-†	26.2	17.9	9.1	11.2	φ 1.22	φ 1.65	1.26	0.94	9.1	2.5-13
1	NECHM-02026-†	25.6	20.5	10.2	11.8	φ 1.22	φ 1.65	1.26	0.94	9.1	2.5-13
2	NECHM-04013-†	32.1	20.5	10.2	11.8	φ 1.22	φ 1.93	1.58	1.18	9.1	3-13
2	NECHM-04026-†	30.3	24.2	11.6	16.9	φ 1.42	φ 1.93	1.58	1.18	9.1	3-13
3	NECHM-06009-†	37	20.5	10.2	13.8	φ 1.69	φ 2.32	1.89	1.38	9.1	3.3-13
3	NECHM-06017-†	36.6	24.2	11.6	16.9	φ 1.69	φ 2.32	1.89	1.38	9.1	4-13
5	NECHM-10010-†	40	20.5	10.2	13.8	φ 2.13	φ 2.36	1.89	6	9.1	4.5-13
7.5	NECHM-15007-†	43	24.2	11.6	16.9	φ 3.3	φ 1.2	11.7	6	9.1	4-13

### Hoist with Motorized Trolley Dimensions (in millimeters)

Cap. (Ton)	Model Number	H	A	B	D	I	K	L	N	T	Flange Width
1/4	NECHM-00526-†	610	455	240	285	φ 31	φ 34	25	19	231	2.5-13
1/2	NECHM-01026-†	610	455	240	285	φ 31	φ 34	25	19	231	2.5-13
1	NECHM-02013-†	655	455	240	285	φ 31	φ 42	32	24	231	2.5-13
1	NECHM-02026-†	650	520	260	300	φ 31	φ 42	32	24	231	2.5-13
2	NECHM-04013-†	815	520	260	300	φ 36	φ 49	40	30	231	3-13
2	NECHM-04026-†	770	615	295	430	φ 36	φ 49	40	30	231	3-13
3	NECHM-06009-†	940	520	260	350	φ 43	φ 59	48	35	231	3.3-13
3	NECHM-06017-†	930	615	295	430	φ 43	φ 59	48	35	231	4-13
5	NECHM-10010-†	1015	615	295	430	φ 54	φ 60	48	43	231	4.5-13
7.5	NECHM-15007-†	43	24.2	11.6	16.9	φ 3.3	φ 1.2	11.7	6	231	4-13

# Hoist Dimensions

## 10 Ton Hoist – Hook Mounted

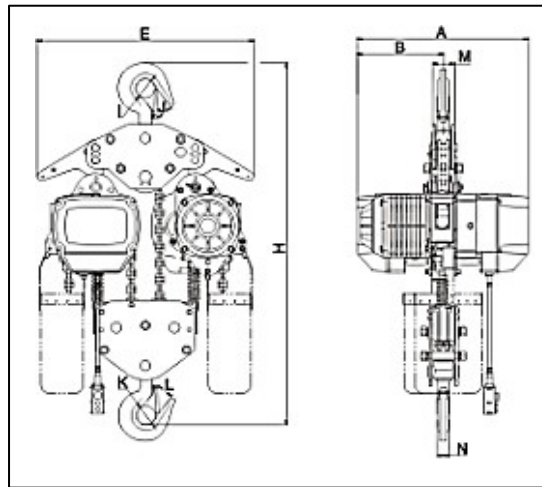

Hoist Dimensions

Cap. (Ton)	Model Number	H	A	B	E	I	J	K	L	M	N
10	NECHH-20010- †	51.6	24.8	12.4	35	φ 3.3	3.1	φ 3.3	3.1	4.1	2.2

## 10 Ton Hoist with Motorized Trolley

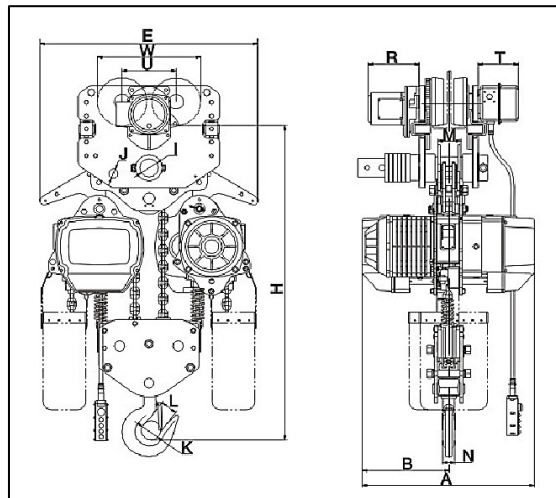

Hoist Dimensions

Cap. (Ton)	Model Number	H	A	B	E	I	J	K	L	M	N	W	U	R	T
10	NECHM-20011- †	43.4	24.8	12.4	35	φ2.8	φ1.4	φ3.35	3.1	3.3	2.2	14.4	7.5	9.1	5.6

### 15 – 25 Ton Hoists with Motorized Trolley

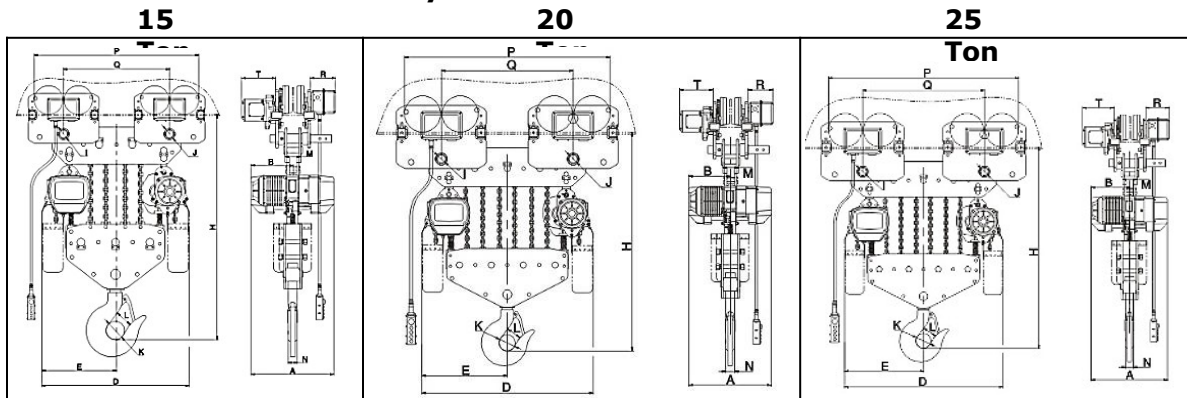

#### Hoist

Cap (Ton)	Model Number	H	A	B	D	E	I	J	K	L	M	N	P	Q	R	T
15	NECHM-30007-†	48.1	24.8	12.4	42.1	21.1	φ2.1	φ2.1	φ4.7	3.8	3.5	3.1	36.5	22	5.6	9.1
20	NECHM-40005-†	54.4	24.8	12.4	49.6	24.8	φ2.8	φ2.8	φ5.9	4.5	3.5	3.7	43.5	29	5.6	9.1
25	NECHM-50005-†	54.4	24.8	12.4	49.6	24.8	φ2.8	φ2.8	φ5.9	4.5	3.5	3.7	43.5	29	5.6	9.1

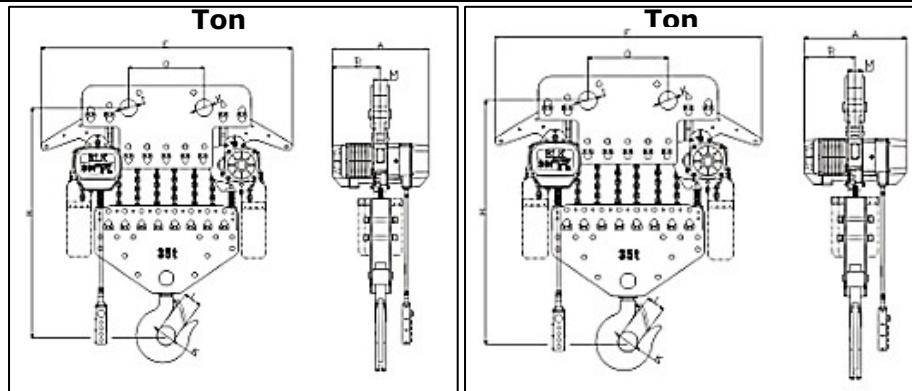

#### Hoist

Cap (Ton)	Model Number	H	A	B	E	I	J	K	L	M	N
30	NECHM-60003-†	61.1	24.8	12.4	59.4	φ3.9	φ3.9	φ7.7	5.5	7.3	5.5
35	NECHM-70003-†	61.1	24.8	12.4	59.4	φ3.9	φ3.9	φ7.7	5.5	7.3	5.5