

OPERATION MANUAL

This operation manual is intended as an instruction manual for trained personnel who are in charge of installation, maintenance, repair etc.



Before equipment use, please read this operation manual carefully.

Serial Number: _____

Date Purchased: _____



TABLE OF CONTENTS

1.0 WARRANTY	6
2.0 SAFETY PRECAUTIONS	7
2.1 Safety Alert Symbols	7
2.2 Important Information and Warnings	8
2.3 Safe Hoisting and OSHA Compliance	9
2.4 Warning Tags and Labels	11
2.5 General Safe Operation Requirements	12
3.0 MODEL NUMBERING	13
4.0 FEATURES	14
4.1 Hoist Features	14
4.2 Pendant Features	15
5.0 INSTALLATION	17
5.1 Prior to Installing Hoist	17
5.2 Installation of Hoist	18
5.2.1 Installation of Hoist with Trolley	18
5.2.2 Installation of Trolley Hoist on the Beam	22
5.2.3 Connecting Power Supply to Hoist	23
5.2.4 Load Chain	23
5.3 Prior To Operation	25
5.3.1 Motor Phasing	25
5.3.2 Trolley Motor Phasing	26
5.3.3 Variable Frequency Drive Setup (VFD)	26
5.3.4 Testing Limit Switches	27
5.3.5 Hoist Load Test	28
6.0 OPERATION	29
6.1 General Safety	29
6.1.1 General DO's and DO NOT'S	30
6.2 Safety Rules before Operating the Hoist	30
6.3 Safety Rules for Operating the Hoist	31
6.4 Safety Rules for Parking the Load	31
6.5 Safety Rules before Each Shift	32
7.0 INSPECTION	32
7.1 Prior to Maintenance or Inspection	32
7.1.1 Inspection Records	33
7.2 Inspection Classification	34
7.3 Daily, Frequent & Periodic Inspections	35
7.4 Hook Inspection	37
7.5 Limit Switch Inspection	39

7.6 Load Chain Inspection	42
7.7 Hoist Motor Brake Inspection	44
7.8 Trolley Inspection	45
7.9 Mechanical Load Brake Inspection.....	47
7.10 Tests.....	49
7.10.1 Operational Test	49
7.10.2 Load Test.....	51
8.0 MAINTENANCE & REPAIR	52
8.1 Lubrication	52
8.1.1 Hoist Gear Housing	53
8.1.2 Load Chain, Hook & Thrust Bearing.....	54
8.2 Chain Maintenance	55
8.3 Chain Replacement.....	55
8.4 Overload Limiting Clutch.....	56
8.5 Hoist Motor Brake Adjustment	56
8.6 Hoist Motor Brake Disassembly.....	58
8.7 Mechanical Load Brake	59
9.0 TROUBLESHOOTING.....	60
10.0 WIRING DIAGRAMS	64
10.1 Electric Chain Hoist, Hook Mounted (Single Speed)	64
10.2 Electric Chain Hoist with Trolley (Single Speed)	64
10.3 Electric Chain Hoist Hook Mounted (Dual Speed)	65
10.4 Electric Chain Hoist with Motorized Trolley (Dual Speed)	65
10.5 Motor Connections.....	66
11.0 DIMENSIONS & SPECIFICATIONS.....	67
11.1 Hoist Specifications.....	67
11.2 Trolley Specifications	73
12.0 EXPLODED VIEWS & PARTS LISTS.....	76
12.1 Exploded View: Housing & Motor	76
12.2 Parts List: Housing & Motor	77
12.3 Exploded View: Gear Case	81
12.4 Parts List: Gear Case	82
12.5 Exploded View: Chaining Parts.....	83
12.6 Parts List: Chaining Parts	84
12.7 Exploded View: Hook Parts	86
12.8 Parts List: Hook Parts.....	87
12.9 Exploded View: Hook Parts (3 Ton 3 Chain)	89
12.10 Parts List: Hook Parts (3 Ton 3 Chain).....	90
12.11 Exploded View: Load Block - 7½ Ton.....	91
12.12 Parts List: Load Block - 7½ Ton.....	92

12.13 Exploded View: Load Block - 10 Ton..... 93
12.14 Parts List: Load Block - 10 Ton 94
12.15 Exploded View: Electrical System..... 95
12.16 Parts List: Electrical System 96
12.17 Exploded View: Motorized Trolley - 1/4 to 5 Ton 97
12.18 Parts List: Motorized Trolley - 1/4 to 5 Ton 98
12.19 Exploded View: Motorized Trolley - 7.5 to 10 Ton 100
12.20 Parts List: Motorized Trolley - 7.5 to 10 Ton 101

1.0 WARRANTY

Warranty

Every hoist is thoroughly inspected and tested before it is shipped from the factory. If any problem develops within one year return the complete hoist prepaid to the factory. If an inspection reveals that the problem is caused by defective workmanship or material, repairs will be made without charge and the hoist will be returned, transportation prepaid.

Excluded Items

This warranty does not cover:

- Deterioration caused by normal wear, abuse, eccentric or side loading, overloading, chemical or abrasive actions, improper maintenance or excessive heat.
- Problems resulting from repairs, modifications or alterations made by people other than factory or ACI representatives.
- The hoist has been abused or damaged due to an accident.
- If repair parts or accessories other than ACI equipment are used on the hoist; they are warranted only to extent that they are warranted by the manufacturer of said parts or accessories.

Remarks

EXCEPT AS STATED HERE, ACI MAKES NO OTHER WARRANTIES, EXPRESS OR IMPLIED, INCLUDING WARRANTIES FOR A PARTICULAR PURPOSE.



Alterations or modifications of equipment and use of non-factory repair parts can lead to dangerous operation and injury.

To avoid injury:

Do not alter or modify equipment.

Do not use equipment to lift, support or otherwise transport people.





Do not suspend unattended loads over people.

2.0 SAFETY PRECAUTIONS

2.1 Safety Alert Symbols

Throughout this manual are steps and procedures that can prevent hazardous situations, the following symbols are used to identify the degree or level of hazard seriousness.

DANGER, WARNING AND CAUTION NOTICE

Symbol	Description
	Danger Indicates an imminently hazardous situation which, if not avoided, will result in death or serious injury and property damage.
	Warning Indicates an imminently hazardous situation which, if not avoided, could result in death or serious injury and property damage.
	Caution Indicates a potentially hazardous situation which, if not avoided, may result in minor or moderate injury or property damage.
	Notice Notifies people of installation, operation or maintenance information which is important but not directly hazard related.



Failure to read and comply with any of the limitations noted in this manual can result in serious bodily injury or death, and/or property damage.

This manual contains important information to help you properly install, operate, and maintain the ACI Electric Chain Hoist for maximum performance and safety purposes. Please study the contents thoroughly before putting the hoist in operation. Only through proper installation, application of correct operating procedures, and by practicing the recommended maintenance procedures, can maximum lifting service from the hoist be expected.

The contents of this manual are of necessity, general in nature and may cover features not incorporated on your hoist; or, you may have ordered features not covered by this manual. Therefore, the user must exercise care in applying instructions given in this manual. If specific information not in this manual is required, contact the factory. Follow all instructions and warnings, failure to operate equipment as directed in manual may cause injury.

NOTICE

It is the responsibility of the owner/user to install, inspect, test, maintain, and operate a hoist in accordance with ASME B30.16, Safety Standard for Overhead Hoists, OSHA Regulations, and ANSI/NFPA 70, National Electrical Code. If the hoist is installed as part of a total lifting system, such as an overhead crane or monorail, it is also the responsibility of the owner/user to comply with the applicable ASME B30 volume that addresses that type of equipment used in the system.

Further, it is the responsibility of the owner/user to have all personnel that will install, inspect, test, maintain, and operate a hoist read the contents of the manual and applicable portions of ASME B30.16, Safety Standard for Overhead Hoists, OSHA Regulations, and ANSII/NFPA 70, National Electrical Code. If the hoist is installed as part of a total lifting system, such as an overhead crane, the applicable ASME B30 volume that addresses that type of equipment must also be read by all personnel. Any ANSI Standards referenced in this manual may be obtained from the American National Standards Institute, 1430 Broadway, New York, NY 10018.

This manual contains information for safe operation of an overhead hoist. Taking precedence over any specific rule, however, is the most important rule of all "USE COMMON SENSE". Operation of an overhead hoist involves more than operating the controls. The operator must consider and anticipate the motions and actions that will occur as a result of operating the controls.

⚠ WARNING

These general instructions deal with the normal installation, operation, and maintenance situations encountered with the equipment described herein. The instructions should not be interpreted to anticipate every possible contingency or to anticipate the final system, crane, or configuration that uses this equipment.

This manual includes instructions and parts information for a variety of hoist types. Therefore, all instructions and parts information may not apply to anyone type or size of specific hoist. Disregard those portions of the instructions that do not apply.

Record hoist serial number on the front cover of this manual for identification and future reference to avoid referring to the wrong manual for information or instructions on installation, operation, inspection, maintenance, or parts.

2.2 Important Information and Warnings

- Equipment described in this manual is not designed for and should not be used for lifting, supporting, or transporting humans.
- To ensure the good working order and reliable operation of the hoist keep strictly to the requirements of the maintenance and operation given in this manual.
- Keep strictly to the requirements for safe operation in order to prevent dangers from the personnel and damages to the electric hoist.
- The repairs shall be furnished only with spare parts supplied by the manufacturer.
- Connection of the electric hoist with the power supply shall be furnished only by a qualified electrician.
- Assemblage and putting the electric hoist into use shall only be done by qualified persons, authorized by ACI Hoist and Crane.

- Modifications to upgrade, rerate, or otherwise alter this equipment shall be authorized only by the original equipment manufacturer or qualified professional engineer.
- Equipment described in this manual may be used in the design and manufacture of cranes or monorails. Additional equipment or devices may be required for the crane or monorail to comply with applicable crane design and safety standards. The crane designer, crane manufacturer, or user is responsible to furnish these additional items for compliance. Refer to ASME B30.17, Safety Standard for Top-Running Single Girder Cranes; ASME B30.2 Safety Standard for Top-Running Double-Girder Cranes; and ASME B30.11 Safety Standard for Underhung Cranes and Monorails. If a below-the-hook lifting device or sling is used with a hoist, refer to ASME B30.9, Safety Standard for Slings, or ASME B30.20, Safety Standard for Below-the-Hook Lifting Devices.
- Hoists and cranes, used to handle hot molten material may require additional equipment or devices. Refer to ANSI Z241.2, Safety Requirements for Melting and Pouring of Metals in the Metal casting Industry.
- The hoists are not designed to operate in chemically aggressive and explosive environments.
- Failure to read and comply with any of the limitations noted herein can result in serious bodily injury or death, and/or property damage.

Be advised working in or near exposed energized electrical equipment presents the danger of electric shock.



HAZARDOUS VOLTAGES ARE PRESENT IN THE CONTROL ENCLOSURE, OTHER ELECTRICAL COMPONENTS AND CONNECTIONS BETWEEN THESE COMPONENTS.

Before performing ANY mechanical or electrical maintenance on the equipment, DISCONNECT the main switch supplying power to the equipment; and implement LOCKOUT/TAGOUT procedure. Refer to ANSI Z244.1, Personnel Protection - Lockout/Tagout of Energy Sources.

Do not operate the equipment without control enclosure cover or covers in place.

Only trained and competent personnel should inspect and repair this equipment.

2.3 Safe Hoisting and OSHA Compliance

The following is a list of the minimum that should be done to keep the hoists and cranes operating properly, safely, and within OSHA regulations. The following should be done to all hoisting equipment including hand and ratchet hoists.

1. Operator Training: Like forklifts and trucks, operator training is required for every operator of hoisting equipment (OSHA 1910.179 b.8). Improper lifts are a major cause of lost time accidents. People operating hoisting equipment must know how to use the equipment safely.
 - ACI offers operator-training classes. Classes include; safe rigging, daily equipment inspection, safe operation, proper use and what can happen with improper use. Classes typically last 1.5 to 2 hours and can be given in English or Spanish.
2. Preventive Maintenance: A preventative maintenance (PM) program shall be established based on the manufacturer's recommendations (ANSI B30 .16 2.3 .1a; OSHA 1910.179 Ll).
 - ACI offers a PM program based on manufacturers recommendations. ACI has factory-trained technicians that utilize the proper equipment to do the job correct, fast, and safe. ACI does not charge for rental of man lifts or forklifts that must be used to operate safely.
3. Qualified Repair Personnel: Adjustments and repairs should be performed by qualified personnel (ANSI B30.16 16-2.3.3 b).

4. Daily Inspections: Many items must be checked on a daily basis. Written records do not need to be kept for these inspections (OSHA 1910.179 j 1; ANSI B30.16).
 - ACI provides operator-training classes to perform these inspections. These quick inspections are completed to verify the unit is safe to use prior to daily operation.
5. Frequent Inspections: These inspections are written inspections required on a monthly basis. (OSHA 1910.179 j1; ANSI B30.16).
 - ACI can provide these inspections or provide training for your personnel to conduct these inspections.
6. Periodic Inspections: These are complete inspections and preventative maintenance of the hoists and cranes. Qualified personnel should determine inspection interval. These should include brake adjustment and lubrication as well as a complete written inspection of your equipment. (OSHA 1910.179 j 2; ANSI B30.16).
 - Based on use and environment ACI can provide these inspections anywhere from a monthly to an annual basis. The inspections are designed to maintain the equipment and reduce the long-term maintenance costs.
7. Records: Dated inspection records shall be kept for inspections and maintenance. (ANSI B30.16 16-2.1.1.2). Records should be kept where easily available. An external marking is acceptable in lieu of records.
 - ACI provides the necessary records. We also keep a copy of all records for your convenience.
8. Load Test: New equipment or equipment that has repairs or alterations to the load handling portion must be load tested to 125% of rated load. (ANSI B30.16 16-2.2.2). A load test should be performed at a minimum of every 4 years (CMAA 78 4.7.4). Load test records must be kept for the life of equipment.
 - ACI has certified test weights to test your hoists and cranes.

NOTICE

There are many special requirements for hoisting systems that should be verified during the design and inspection of the equipment. It is extremely important for safe operation that the system is designed and maintained by qualified personnel. ACI would be pleased to provide this service.

2.4 Warning Tags and Labels

The warning tag illustrated below is supplied with each hoist shipped from the factory. If the tag is not attached to your hoist's pendant cord, call ACI Hoist & Crane immediately to receive it and install it. Read and obey all warnings attached to this hoist. Tag is not shown in actual size.

**ONLY QUALIFIED PERSONNEL
SHALL OPERATE THIS EQUIPMENT**

DO NOT:

- Remove, deface or obscure this label.
- Operate malfunctioning equipment.

BEFORE OPERATING

DO:

- REPORT condition for repair by qualified person.
- READ Mfr's. Instruction. Applicable American national Safety Standards.
- CHECK ROPE OR CHAIN
 - Must be seated in grooves, sheaves or sprockets.
 - Must not be twisted, kinked or damaged in any way.
- CHECK CONTROLS
 - All limit switches must function properly
 - Hook travel must be in the same direction as shown on controls.
- CLEAR all personnel from service platform and path of load.

WHILE OPERATING

DO NOT:

- Lift more than rated load.
- Lift people or loads over heads of people.
 - WARN personnel of approaching loads.
- Make side pulls, Lift all loads vertically.
- Use limit switches as routine operating stops.
 - THESE ARE EMERGENCY DEVICES ONLY
- Operate if rope (or chain) slips from grooves (or sprockets). REPLACE in grooves (or sprockets) before continuing operation.

BEFORE LEAVING OPERATING POSITION

- DO NOT leave a load suspended and unattended.
- ALWAYS disconnect from power supply when equipment is not in use.

ACI
Call: (954)367-6116
WWW.ACIHOIST.COM

2.5 General Safe Operation Requirements

WARNING

Before installing, removing, inspecting, or performing any maintenance on a hoist, the main switch shall be de-energized. Lock and tag the main switch in the de-energized position in accordance with ANSI Z244.1.

Follow other maintenance procedures outlined in the manual and applicable ASME B30 volumes.

Additional **WARNINGS** are listed in various portions of this manual. Personnel shall read and follow these **WARNINGS**. Failure to read and comply with these **WARNINGS** as well as other instructions or any limitations noted in this manual and applicable ASME B30 volumes could result in serious bodily injury or death, and/or property damage.

- Read and observe the instructions and warnings contained in this manual. Read and observe any instructions and warning tags attached to the hoist.
- Check for any damage to the hoist during shipment. Check carefully to ensure the cable, gearbox, and motor shell are not damaged. If any damage has occurred, place a claim with the carrier. **DO NOT** install a damaged hoist.
- Check that the crane, monorail, or other supporting structure where the hoist will be installed has a load rating capable to handle loads equal to the rated load capacity of the hoist.
- Check lubricant in gear housing. Oil level should be even with oil level plug in housing. If additional gear housing lubricant is required, refer to the LUBRICATION section of this manual. Lubricate any exposed gears and pinions on the trolley.
- Be certain the power supply to the hoist and trolley have the same voltage, frequency, and phase that are specified on the hoist and trolley nameplate.

Every hoist should be equipped with the following standard accessories:

- One Chain Container
- Control Cable
- One Control Station

Before using the hoist, fill in the information below:

Model Number: _____

Serial Number: _____

Purchase Date: _____

Installation **MUST** be performed by a qualified person in accordance with ACI Hoist & Crane. Severe injury, death and/or property damage can result if the hoist is not correctly installed. For service in this area, please contact:

ACI Hoist & Crane
689 SW 7th Terrace
Dania Beach, FL 33004
Phone: 954-367-6116
Fax: 954-272-0334
Toll Free: 1-866-424-6478

3.0 MODEL NUMBERING

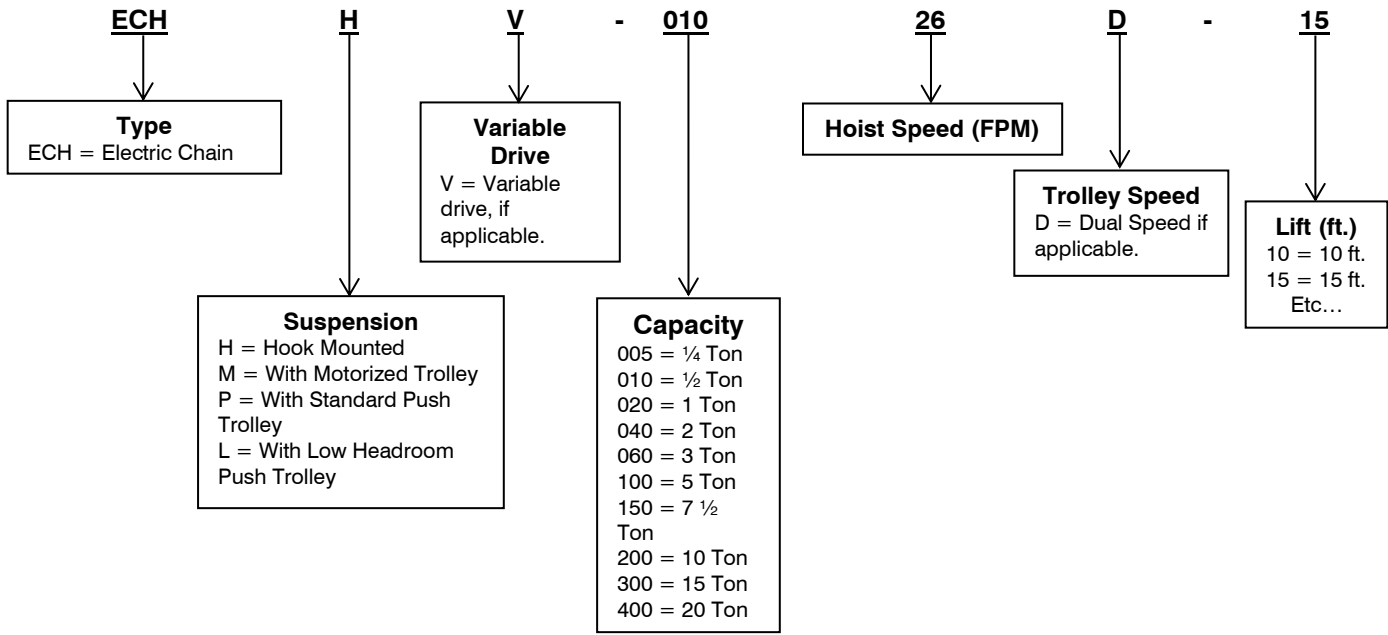

4.0 FEATURES

4.1 Hoist Features

Table 4.1.1
Features

Feature	Description
Duty Cycle	H4 Duty
Chain Guide	Provides quiet and smooth guiding of the chain for improved wear and jam resistance.
Rain Cover	Optional. Recommended for outdoor application.
Load Sheave	Deep-grooved with five pockets, which reduces vibration and chain wear as well as providing a true vertical lift.
Gears	Precision machined, heat treated helical and spur gears.
Oilbath Lubrication	Provides quiet, smooth and cool operation.
Mechanical Load Brake	Secondary Weston style load brake as an added safety feature, located inside the gear box.
Motor Brake	Pull-rotor type. An extremely durable and advanced design with few moving parts. Contains no brake coil which can fail, like in conventional multi-disk brakes. Standard feature.
Overload Clutch	A long life friction clutch protects the hoist from damage and prevents overloading.
Motor	Aluminum die cast body that is light weight with a baked paint finish. Has an increased performance through heavy duty H4 rating and has standard thermal protection.
Limit Switches	Power upper and lower limit switches that cut power directly to the motor. This added safety device is required in hot metal and critical uses.
Hook	Forged carbon steel hook. Under excessive loads the hook will not snap, instead it will open gradually. It contains ball bearings which allow for smooth rotation, the hook will swivel 360 degrees.
Load Chain	Heavy-duty, heat-treated, wear-resistant load chain which is standard.
Chain Bag	Heavy-duty chain bag included as a standard feature.
Lifting Eye	A standard feature that is required in many specifications for equipment over 40 pounds.
Trolley	Motorized trolley is available, in addition to push and low headroom push trolleys.
Trolley Bumper	Standard feature on our trolleys, a required item on trolleys used for cranes.
Trolley Brake	Standard feature.
Trolley Roller Guides	Trolley roller guides for smooth operation, especially on curves, standard on trolleys.

4.2 Pendant Features

When using a pendant control, depress the up button to raise the hoist or the down button to lower the hoist as shown in Figure 4.2.1 below. To stop motion, release the buttons.

⚠ CAUTION

Ensure the motor comes to a complete stop before reversing the direction.

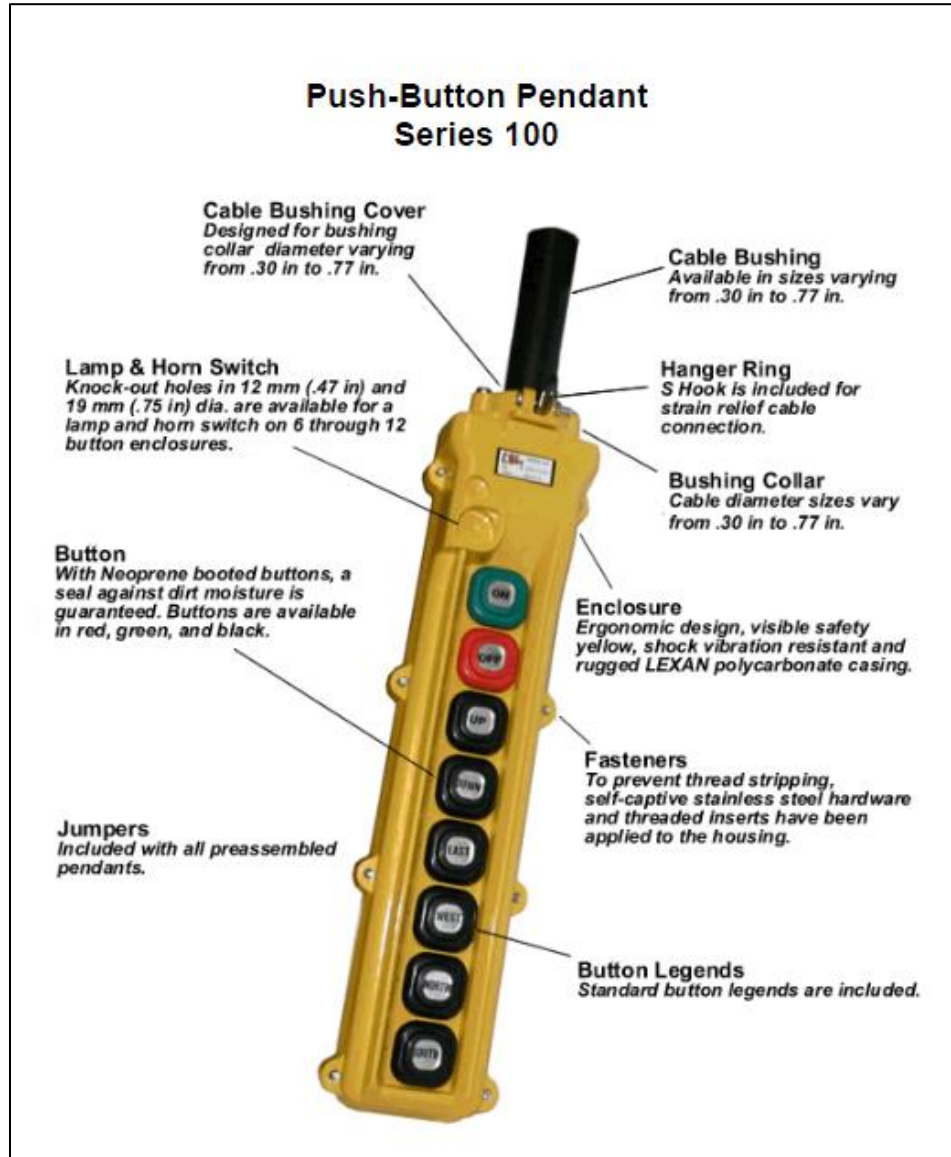
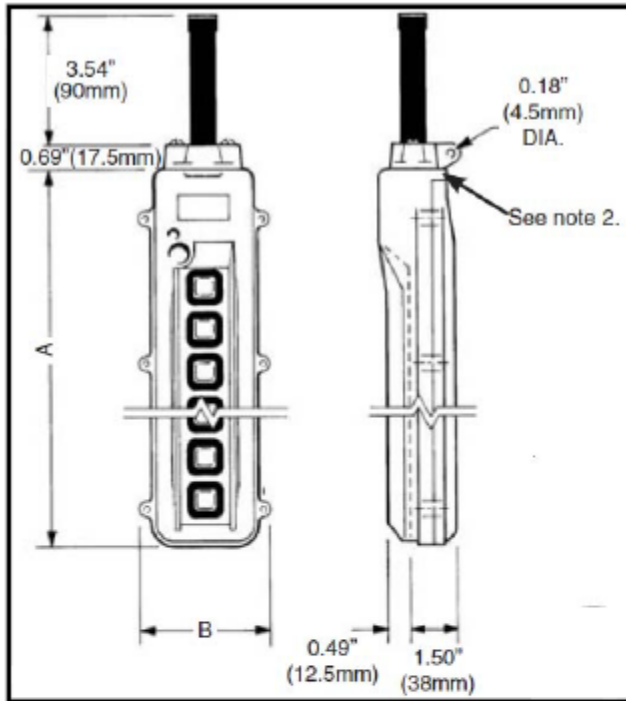

Figure 4.2.1

Table 4.2.1
Push Button Station Dimensions



No of positions	A		B	
	(in)	(mm)	(in)	(mm)
2	4.49	114	3.07	78
4	7.09	180	3.07	78
6	10.31	262	3.23	82
8	12.68	322	3.23	82
10	15.24	387	3.43	87
12	17.60	447	3.43	87
12-24	See note 1			

Note 1: Please consult the factory for custom design.

Note 2: Bushing collar can be mounted facing front or rear

Bushings

Cable bushing	Cable size	
	Diameter (mm)	Diameter (in)
100COBA1	7.5 – 10.5	.30 - .41
100COBA2	10.3 – 13.5	.41 - .53
100COBB1	13.3 – 16.5	.52 - .65
100COBB2	16.3 – 19.5	.64 - .77
100COBC1	19.3 – 22.5	.76 - .89
100COBC2	22.3 – 25.5	.88 - 1.00
100COBD1	25.3 – 28.5	1.00 - 1.12
100COBD2	28.3 – 29.5	1.11 - 1.16

5.0 INSTALLATION

ACI Electric Chain Hoists are lubricated and tested before being shipped from the factory. To place a hoist in service, install the hoist onto a beam by adjusting the hoist appropriately for the flange width. Then connect it to an electrical service and perform pre-operation tests, checks and inspections.

WARNING

Only qualified personnel with proper supervision shall install the hoist on the monorail and perform the final pre-operation inspection.

Before installing, removing, inspecting, or performing any maintenance on a hoist, the main switch shall be de-energized. Lock and tag the main switch in the de-energized position in accordance with ANSI Z244.1.

Follow other maintenance procedures outlined in this manual and applicable ASME B30 volume(s). Additional WARNINGS are listed in various portions of this manual. Personnel shall read and follow these WARNINGS. Failure to read and comply with these WARNINGS as well as other instructions or any limitations noted in this manual and applicable ASME B30 volumes could result in serious bodily injury or death, and/or property damage.

WARNING

Prior to installing the hoist check for any damage that may have occurred to the hoist during shipment.

DO NOT install a damaged hoist.

5.1 Prior to Installing Hoist

- Read and observe the instructions and warnings contained in this manual. Read and observe any instructions and warning tags attached to the hoist.
- Locate any vent plugs attached to or included with the hoist and trolley. Remove solid shipping plug or plugs.
- Check that the crane, monorail, or other supporting structure where the hoist will be installed has a load rating capable to handle loads equal to or greater than the rated load capacity of the hoist.
- If hoist is to be installed on an existing crane, the crane should be run to a location where it will cause the least interference with other cranes and operations in the area; and all controllers placed in the off position.
- If the hoist is to be installed on an existing crane, and the crane runway remains energized because of other cranes operating on the same runway; stops or a signal person(s), located full-time at a visual vantage point for observing the approach of active crane(s), shall be provided to prohibit contact by the active crane(s) with the idle crane.
- If personnel will be required to work on the runway during installation, a guard or barrier shall be installed between adjacent runways for the length of the established work area to prevent contact between persons performing installation and a crane on the adjacent runway.
- If personnel are required to work at elevations in excess of 6 feet above floor or ground level, a fall prevention policy and procedure shall be developed, documented, and implemented prior to installation.

- Check power supply that will be furnished to the hoist and trolley. It must be the same as shown on the hoist and trolley serial plate.
- Check load chain for damage. Be sure load chain is properly seated in load sheave and sheave pockets.
- After repair and reassembling of the electric hoist check the phasing and the limit switch adjustment for upper and lower position of the loading hook.
- While conducting maintenance and repair activities for electric repairs/maintenance, make sure that there is no load on the hook; the power supply switch is turned off and unauthorized switching on is eliminated.
- Check the loading hook for cracks and deformities as well as the good working order of the fuse for self-release of the load.
- Check the connection of cable protective conductors to the grounding terminals in the electric board as well as the transformer and electricity.
- If the hoist has a trolley, check that the crane bridge beam or monorail beam is level, straight, and clean. Check that trolley stops are installed, or install trolley stops, at the open end or ends of the beam to prevent the trolley from traveling off the beam. Trolley stops that engage trolley wheels are not recommended. Check that trolley stops will prevent overhanging parts of the hoist and trolley from interfering with other equipment beyond the ends of the beam or monorail.

⚠ WARNING

The main switch (disconnect) supplying power to the crane, monorail, or other piece of equipment where the hoist is to be installed, shall be de-energized. Lock and tag the main switch in the de-energized position in accordance with ANSI Z244.1.

5.2 Installation of Hoist

Prior to mounting the hoist ensure that the suspension and its supporting structure are adequate to support the hoist and its loads.

- **Hook Mounted** – Attach the hoist’s top hook to the fixed suspension point. Ensure that the fixed suspension point rests on the center of the hook’s saddle and that the hook’s latch is engaged.
- **Lug Mounted** – Fasten securely with lug suspension pins. Check that there are no obstructions to the operation of the hoist including the path of the chain. Use only the lug mounting hole for suspension of the hoist.
- **Under Running Trolley Hoist Unit** - Trolley is mounted on hoist and shipped as one unit. Trolley will operate on standard S-shapes or W-shapes flanges.

5.2.1 Installation of Hoist with Trolley

If the trolley hoist is mounted on a skid, do not remove it immediately. The skid will hold the trolley hoist unit in an upright position until assembled on the crane or monorail.

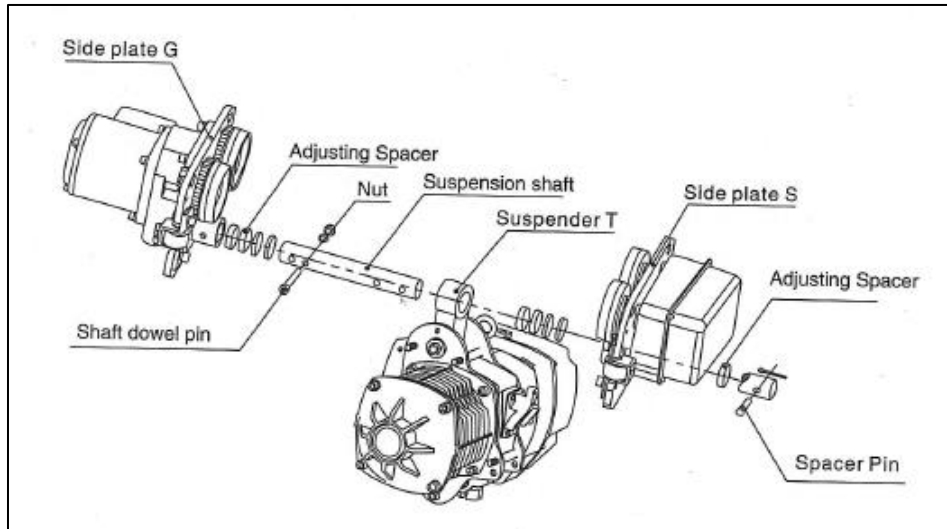

Figure 5.2.1.1

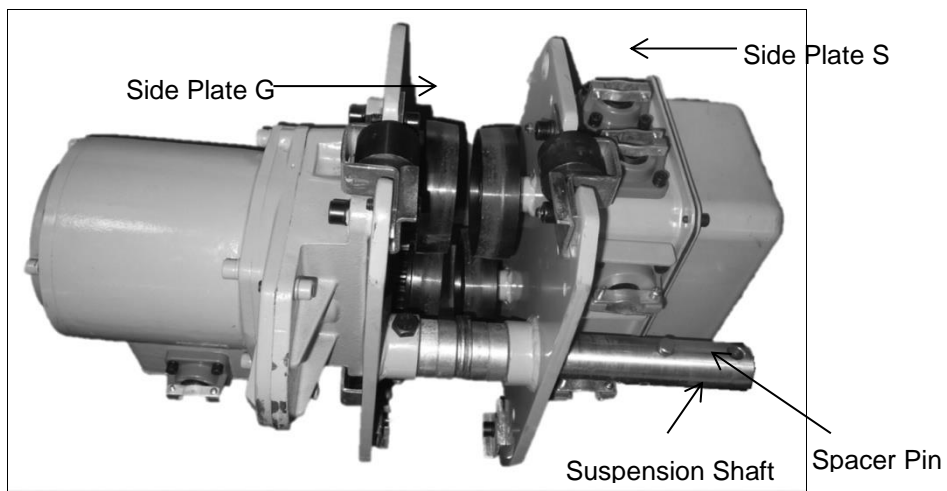

Figure 5.2.1.2

1. Remove cotter pin from trolley shaft dowel pin (Spacer Pin) and slide suspension shaft out of side plate S (refer to Figures 5.2.1.3 and 5.2.1.4).

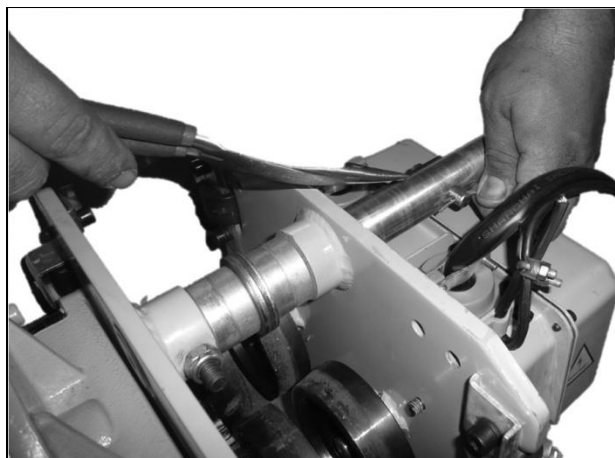

Figure 5.2.1.3

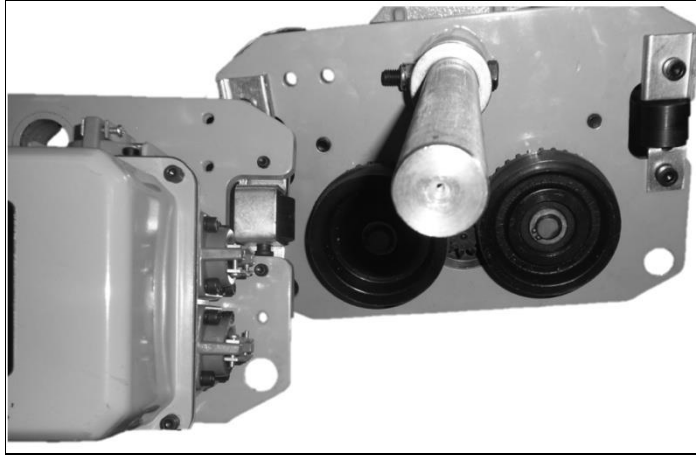

Figure 5.2.1.4

2. Measure the flange width of the beam where the trolley is to be installed.
3. Slide one stack of inner adjusting spacer over the suspension shaft. Total width should be about half of the flange width of the beam. Then insert suspension shaft into suspender T (refer to Figure 5.2.1.5).

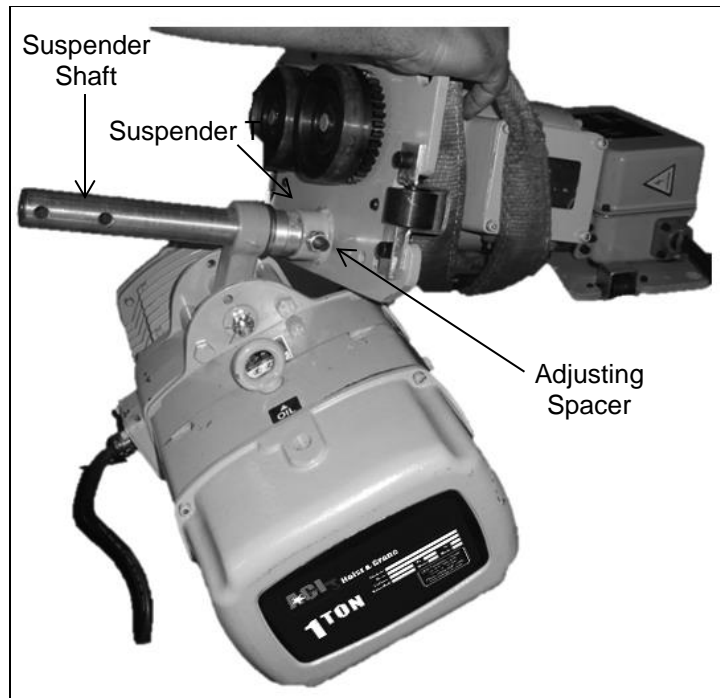

Figure 5.2.1.5

4. Slide same size of inner adjusting spacer stack next to the suspender T and install side plate S to the suspender shaft (refer to Figure 5.2.1.6).

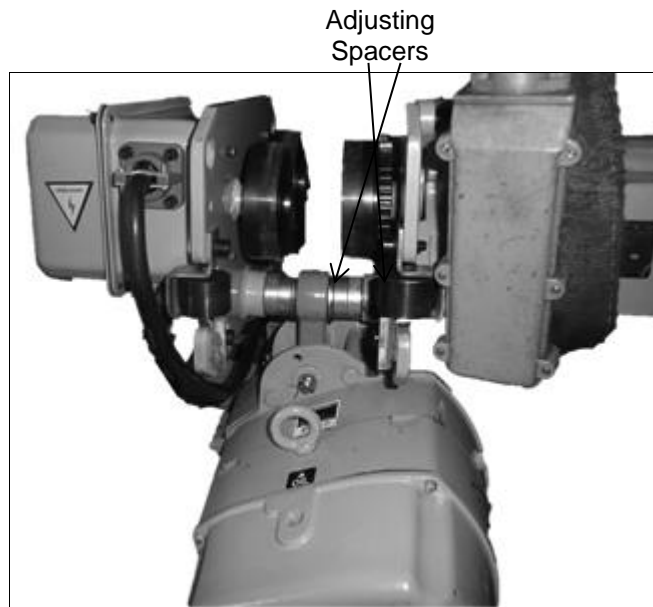

Figure 5.2.1.6

5. Secure the shaft with spacer pin and cotter pin.
6. Refer to Figure 5.2.1.7 for adjusting the width of the trolley by installing inner and outer adjusting spacers on the suspension shaft.

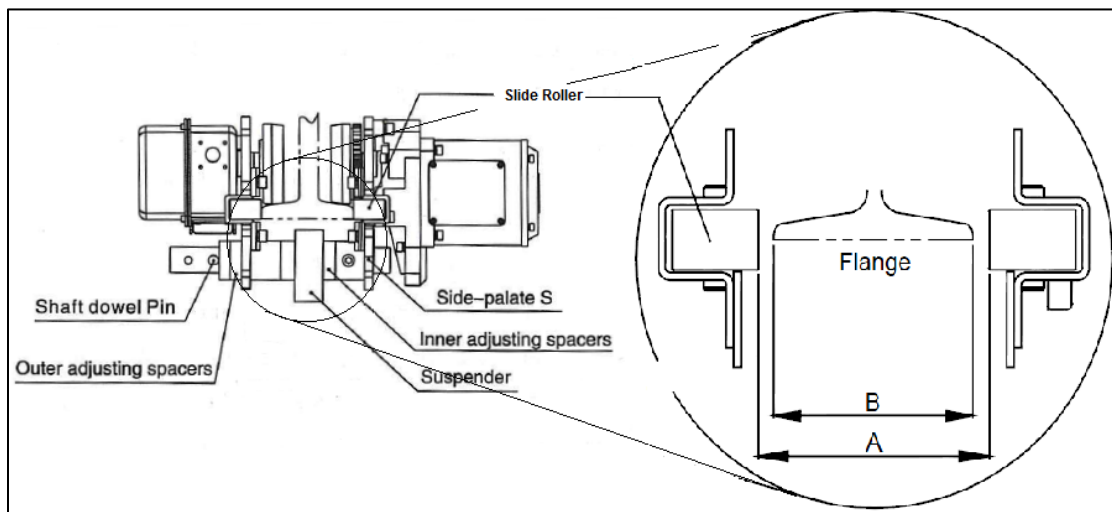

Figure 5.2.1.7

7. Make sure both side plates are spread fully outward and measure dimension "A". Dimension "A" must be $5/32$ " (4 mm) greater than "B" (refer to Figure 5.2.1.7).
8. Rearrange spacers, if necessary, to achieve proper spacing. Distribute washers equally so that the hoist will be centered between trolley side plates and under beam.
9. After obtaining the proper adjustment, secure the shaft with spacer pin and cotter pin.

Even if the unit was ordered for a specific beam size or beam flange width; check trolley wheel spacing between wheel flanges.

5.2.2 Installation of Trolley Hoist on the Beam

1. Place trolley hoist in correct position relative to bridge beam or monorail, orienting it for proper end approach in accordance with specification requirements. Be sure that collectors and conductors are properly positioned and aligned.
2. Place Trolley hoist unit in position on bridge beam or monorail. Check that trolley bumpers, if provided, meet trolley stops on beam, reposition if necessary.
3. The simplest ways to mount the trolley hoist on the beam, as long as the crane or building construction permits it, is to remove the trolley stops on an open end of the beam, run the trolley onto the beam and replace the trolley stops. If this method is not possible due to crane or building interference, mount the trolley hoist according to the following instructions (refer to Figure 5.2.2.1).

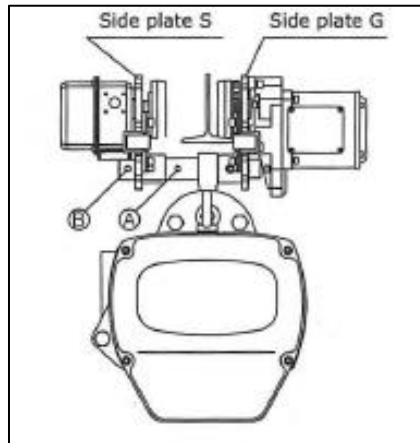

Figure 5.2.2.1

1. Remove side plate assembly, with the wheels intact, from one side of the trolley only, by removing the spacer pin from the suspension shaft hole A. Then insert it into hole B. Insert cotter pin in the spacer pin to fix it in place. On geared and motorized trolleys it is recommended that the side with the plain wheels be removed.
2. Spread side plate G and side plate S apart. Lift the trolley up to the beam; keep both sides of the wheel and beam at the same level.
3. Support one side plate then push the other side towards the supported side to prevent it from shedding from the beam. Keep the wheel and the beam at the same level.
4. Remove the spacer pin from hole B and insert it into hole A. Secure the spacer pin with the cotter pin.
5. Check that the hoist is centered between trolley side plates and centered under the beam.
6. The load block must hang straight and directly under the hoist. The load chain must be free of kinks, twists or any other damage.



If the load chain welding points are not inline you must replace the load chain before use.

Trolley hoists are balanced at the factory based upon the condition of the hoist “as ordered” and “as shipped”. Auxiliary equipment or devices furnished and mounted by others may require additional counterweights to balance the hoist. It is the responsibility of the party mounting such auxiliary equipment or devices to add additional counterweights as necessary and required.

5.2.3 Connecting Power Supply to Hoist

! DANGER

Disconnect power and lockout and tag the power before connecting the power supply to the hoist to prevent accidental application of power.

Only a qualified person should connect the power supply to the hoist.

Check the power supply that will be connected to the hoist to ensure that it is the same voltage as shown on the hoist serial number plate. If the power supply that will be connected to the hoist is not the same as shown on the hoist serial number plate, **DO NOT** connect the power supply to the hoist. Make all electrical connections in accordance with the wiring diagram in chapter 10.

5.2.4 Load Chain

After installation of hoist to the beam check the load chain utilizing the following steps:

1. Check the location of the welding points on the chain. All welds should be inline (refer to Figure 5.2.4.1).
2. Check for twists and kinks in the chain (refer to Figure 5.2.4.2).
3. Raise the load block without a load to within three feet of driving load sheave.
4. Check the direction of the chain movement, for example, if you press up on the pendant the chain should raise.

! WARNING

If load chain is damaged, DO NOT use hoist until load chain is replaced.

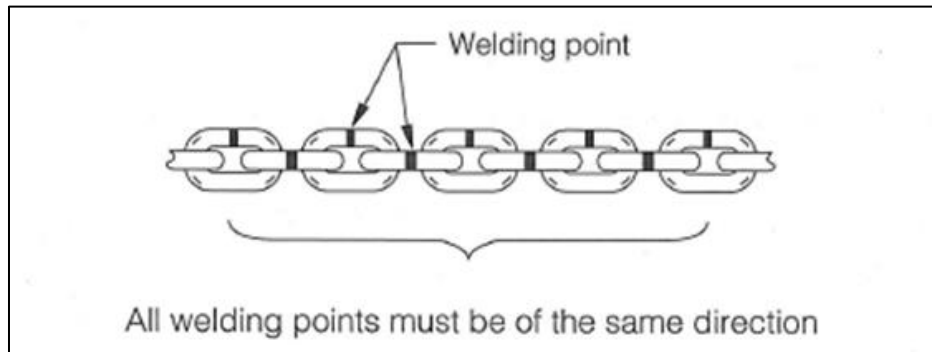

Figure 5.2.4.1

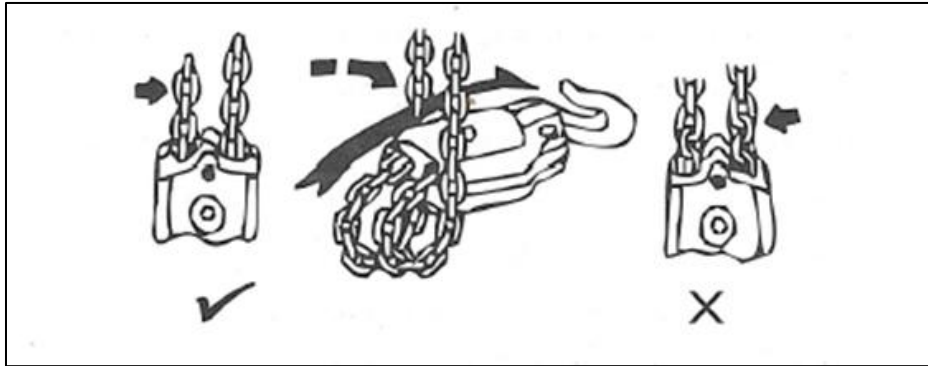

Figure 5.2.4.2

At this time the chain container should be installed utilizing the following procedures:

1. Lower hoist hook until lower limit switch stops downward motion of hook.
2. Place container on hoist and secure it in place with the chain container pins and cotter pins. Orient the container as shown in Figure 5.2.4.3.
3. Place loose end of chain with chain stop into the container. The loose end of the chain should flow into the container.

DO NOT use a chain container with a storage capacity less than the lift length on the hoist (refer to Table 5.2.4.1)

Table 5.2.4.1
Chain Bag Dimensions

Model Number	Chain Length (ft.)	Size of Chain Bag (In.)	Material
8#	< 19.7	5.9 x 5.9 x 7.9	Canvas
8#	< 28.9	5.9 x 5.9 x 11.8	Canvas
12#	26.2 – 52.5	8.3 x 8.3 x 17.7	Canvas
14#	26.2 – 52.5	8.3 x 8.3 x 17.7	Canvas
Other	> 65.6	/	Steel

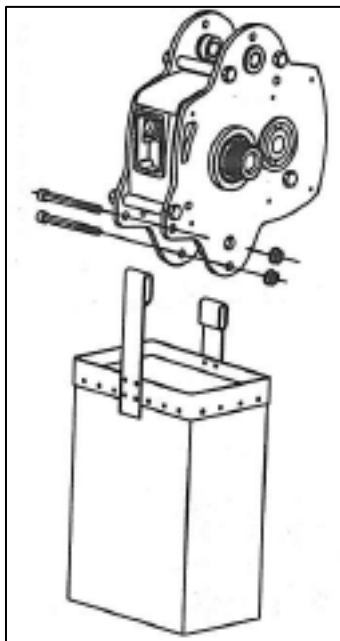

Figure 5.2.4.3

5.3 Prior To Operation

- Before energizing the power supply, and inspecting and testing the hoist prior to initial operational use, check that all electrical connections are in accordance with the wiring diagram.
- ASME B30.16 requires that all new, altered, or modified hoists be inspected by a designated person prior to initial use to verify that the equipment and installation comply with applicable provisions of the standard. Such an inspection should be performed at this time, using ASME B30.16 as the basis for inspection procedures.
- Energize the power supply to the hoist

5.3.1 Motor Phasing

Since motor rotation of a three-phase AC motor can be changed by reversing any two of the lines feeding power to the motor, the direction of the hook motion must be checked to verify that it is correct in accordance with the hoist control device markings. For example, when pressing up on the hoist pendant the chain should ascend.

To check hook motion direction and/or motor phasing do the following:

WARNING

DO NOT activate the down button of the hoist control device. If the hoist motor is improperly phased, hook will move up and cause possible damage to the hoist.

MOMENTARILY activate the **UP** button of the hoist control device and observe the direction of the hook motion. If the direction of the hook travel matches the direction marking of the hoist control device button activated then the hoist motor is properly phased. If the direction of the hook travel does not match the direction marking of the hoist control device button activated, for example when you press UP the hook descends; then the hoist motor is improperly phased and must be corrected. **DO NOT** use the hoist until motor phasing is corrected.

WARNING

DO NOT attempt to correct an improperly phased hoist by changing any wiring in the hoist control device or at the hoist connectors; or by changing the markings on the hoist control device.

WARNING

DO NOT operate the hoist if the direction of the hook travel and the marking on the hoist control device activated **DO NOT** match.

Utilize the following steps to correct hoist motor phasing:

DANGER

- 1 Disconnect the power, lockout and tagout the power supply before working on the electrical wiring to prevent accidental application of power.
- 2 Only a qualified person should disconnect or connect the power lines to the hoist.

3. Interchange any two lines supplying power to the hoist.
4. Re-energize power supply to the hoist.
5. Check the hoist travel direction for correct hook motion by pressing **UP** on the hoist control device. If the direction of the hook travel matches the direction marking of the hoist control device button activated then the hoist motor is properly phased. If the direction of the hook travel does not match the direction marking of the hoist control device button activated the hoist motor is improperly phased and must be corrected by repeating steps 1 through 5.

5.3.2 Trolley Motor Phasing

If the hoist has a motorized trolley please see the trolley's operation manual for proper motor phasing.

5.3.3 Variable Frequency Drive Setup (VFD)

DANGER

To avoid a shock hazard, **DO NOT** perform any mechanical or electrical maintenance on the dual speed (VFD Control) trolley or hoist within 5 minutes of de-energizing (disconnecting) the trolley or hoist. This time allows the interval VFD capacitor to safely discharge.

WARNING

DO NOT remove power to the dual speed VFD Control hoist or trolley during operation.

- Some dual speed hoists may be equipped with a VFD. The VFD is used to control the high and low lifting speeds. The speeds come preset from the factory at a 6:1 speed ratio. The speed (frequency) can be customized.
- Some trolleys may be equipped with a VFD. The VFD will be setup for infinite speed control.
- The VFD is controlled by a Keypad/Display Interface. Refer to Figure 5.3.3.1 for Keypad/Display Interface functions and descriptions.

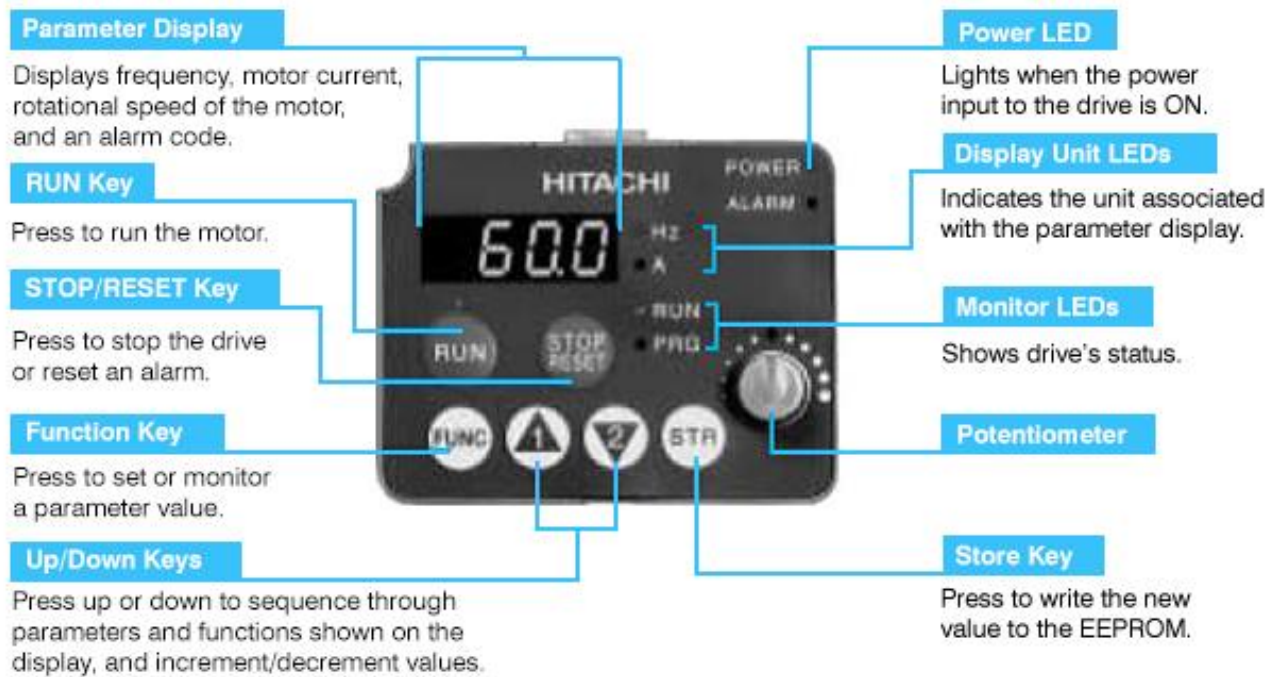

Figure 5.3.3.1

5.3.4 Testing Limit Switches

All testing of limit switches should be accomplished without a load on the hook of the hoist. All tests should be accomplished by using the low speed of variable-speed hoists, or inched into the limit if the hoist is a single-speed unit. Before checking limit switches the function of limit rocker arms should be checked by pushing the rocker arms up and down to ensure they function properly.

⚠ WARNING

Never operate the hoist without the protection of properly functioning limit switches.

Hoist limit switches shall **NOT** be used as a normal means of stopping travel motion or the load; these are emergency devices only.

The primary upper and lower limit switch should be checked without a load on the hook at the start of each shift, or before the first time the hoist is to be operated during each shift.

These instructions apply to limit switch adjustment for an unloaded load block only. Limit switches must be adjusted to prevent the load block or the load being lifted from coming into contact with any part of the hoist, crane, hoist support structure, or other equipment where the hoist is installed.

To check lower limit device, operate the hoist in the lowering direction until motion of the load block stops. While lowering the load block, watch the length of the load chain on the unloaded side of the hoist. If the loop will become taut before the lower limit device stops load block motion, **STOP** the hoist motion, the lower limit device requires adjustment. The hoist lower limit device is set at the factory to stop lower travel of the load block with approximately nine to fifteen (9-15) links of load chain extending beyond the chain guide on the unloaded side of the hoist. It is recommended that the lower limit device be set to prevent the load block from resting on the floor and allowing the load chain to go slack. If adjustment of the lower limit device is required, refer to the Limit Switches section of this manual.

To check upper limit device, operate the hoist in the lifting direction to a point where the block is about 12 inches below the hoist. If the hoist has more than one speed, continue to raise the load block at low speed or if hoist is a single speed unit inch the load block in the lifting direction until motion of the load block stops. If the load block will hit the hoist or hoist frame before the upper limit device stops the load block motion, **STOP** the hoist motion, the upper limit requires adjustment. If adjustment of the upper limit device is required, refer to the Limit Switches section of this manual.

1. Operate the hoist without a load on the hook through the entire lifting range to ensure that the limit switches function properly and that the load block and hook do not interfere with any other items or pieces of equipment located in the operating area.
2. If the hoist has a trolley, operate the trolley without a load on the hoist hook for the entire travel distance of the trolley to ensure that the trolley, hoist, load block and hook do not interfere with any other items or pieces of equipment located in the travel path.

The hoist is now ready to be load tested, if required.

5.3.5 Hoist Load Test

Complete hoists are load tested by Manufacturer in accordance with ASME B30.16. If the hoist is installed on a crane, load testing of the crane in accordance with, as applicable, ASME B30.2, ASME B30.11, or ASME B30.17 may be required.

Prior to operating hoist for the first time, the hoist should still be test operated, as follows, with a load on the hoist hook.

1. Attach a load to the hoist hook. Load shall not exceed the rated load capacity of the hoist.
2. Before lifting the load, operate the hoist in the raising direction to take any slack out of the hoist load chain.
3. Raise the load a few inches and stop the hoist. If brakes stop and hold the load, continue raising and lowering the load several feet, stopping the hoist several times in each direction to check that the hoist braking system stops and holds the load.
4. If the hoist braking system stops and holds the load, the hoist operates in accordance with the control devices, and no unusual sounds are present during operation, the hoist is ready to be released for operating purposes.
5. If the hoist braking system does not stop and hold the load, the hoist does not operate in accordance with the control devices, or any unusual sounds are present during operation, the hoist is not ready to be released for operating purposes; corrective action must be taken.

6.0 OPERATION

The operator of the hoist must be well acquainted with this manual and be instructed on the requirements for safe operation. The operator's clothing should be in accordance with working conditions. The operator should always have at hand the operation manual or a copy of the Operation and Safety sections, which must be placed near power circuit breaker or on an easy and accessible place.

All personnel that will operated the hoist shall read the Operation section of this manual, the **DANGER, WARNING, CAUTION**, and **NOTICES** contained in this manual, and instruction and labels on the hoist before operating the hoist or lifting system.

Operation of an overhead hoist involves more than activating the buttons of the hoist control device. It is emphasized in ASME B30 Safety Standard that the use of overhead hoists is subject to certain hazards that cannot be met by mechanical means, but only by the exercise of intelligence, care, common sense and experience in anticipating the motions that will occur as a result of activating the hoist controls. Certain precautions are necessary before moving the load and this includes the proper rigging of loads to the hoist hook.

WARNING

Hoist operators **SHALL** be required to read the operation section of this manual, the **DANGERS, WARNINGS, CAUTIONS** and **NOTICES** contained in this manual, operation instructions and labels on the hoist or lifting system, and the operation section of ASME B30.16, and to be familiar with the hoist and hoist controls before being authorized to operate the hoist or lifting system.

Hoist operators should be trained in proper rigging procedures for the attachment of loads to the hoist hook.

Hoist operator should be trained to be aware of potential malfunctions of the equipment that require adjustment or repair, instructed to stop operation if such malfunctions occur, and immediately advise their supervisor so corrective action may be taken.

Hoist operators should have normal depth perception, field of vision, reaction time, manual dexterity, and coordination.

Hoist operators should not be subject to seizures, loss of physical control, physical defects, or emotional instability that could result in actions of the operator being a hazard to the operator or others.

Hoist operators should not operate a hoist or lifting system when under the influence of alcohol, drugs, or medication.

Overhead hoists are intended only for vertical lifting service of freely suspended unguided loads. Do not use hoist for loads that are not lifted vertically, loads that are not freely suspended, or loads that are guided.

6.1 General Safety

Safe operation of an overhead hoist is the operator's responsibility. Listed below are some basic rules that can make an operator aware of dangerous practices to avoid and precautions to take for his or her own safety and the safety of others. Observance of these rules, in addition to frequent examinations and periodic inspection of the equipment, may save injury to personnel and damage to equipment.

- The operator shall know hand signals used for hoist and crane operations, if a signalperson is used in the operation, and accept signals of only persons authorized to give hand signals **EXCEPT** to obey a stop signal regardless of who gives it.
- The operator shall **NOT** adjust or repair a hoist unless qualified and authorized to perform maintenance.

- The operator shall **NOT** use the hoist load limiting devices as a means to measure the load.

6.1.1 General DO's and DO NOT'S

- **DO** establish a regular inspection schedule and maintain a record of all inspections performed with special attention directed to the chain, hooks, and breaks.
- **DO** remove the hoist from service and perform necessary maintenance and repair.
- **DO** follow recommended maintenance procedures for taking a hoist out of service to inspect and perform maintenance and repair.
- **DO** use the original hoist manufacture's recommended parts when repairing a hoist and replacing worn or damaged parts.
- **DO NOT** allow unqualified or unauthorized personnel to operate, inspect, maintain, or repair the hoist.
- **DO NOT** operate a hoist that is damaged or has any actual or suspected mechanical or electrical malfunction.
- **DO NOT** use the chain, any part of the hoist, or the load block and hook as a ground for welding.



DO NOT walk under a suspended load.

DO NOT perform any work on a suspended load that requires a worker to be positioned under the suspended load.

If it is essential that a worker be positioned under a suspended load to perform work on the suspended load, such work shall not be started or performed until other auxiliary supporting means are placed under the suspended load. Failure to use other auxiliary supporting means could result in serious bodily injury or death, and/or property damage.

6.2 Safety Rules before Operating the Hoist

- Be familiar with all operating controls of the hoist.
- Be familiar with the operation procedures of this manual, the **DANGERS, WARNINGS, CAUTIONS** and **NOTICES**, also the procedure of instructions and labels on the hoist and lifting system.
- **DO NOT** operate the hoist if any damage or malfunctions exist or are suspected to exist. All suspected or actual malfunctions and damage **SHOULD** be reported to the supervisor.
- **DO NOT** operate if tagged with an out of order sign.
- **DO NOT** use the hoist load chain as a sling to wrap around the load.
- Attach the load to the hoist hook by proper means such as slings or lifting devices.
- Only attach a load to the hoist hook that does **NOT** exceed the rated load capacity of the hoist.
- Confirm that the size of the attachment of the sling or other lifting device to be used is compatible to the size of the hoist hook.
- Confirm that the attachment part of the sling or other lifting device is properly seated in the base, bowl, or saddle of the hoist hook.

- Conform that the hook latch operates properly and that the hook latch properly bridges and closes the hook throat opening.
- Confirm that the latch of the hoist hook will not support any part of the load.
- Conform that the load or any part of the load will not be applied to and/or not supported by the tip of the hook.
- Confirm that the load will be properly balanced when lifted.
- Confirm that the hoist load chain is not kinked or twisted, and that the load chain parts are not twisted around each other.
- Confirm that the hoist load chain is properly seated in the load sheave and sheave pockets.
- Notify personnel in the area that a load will be lifted and verify that all personnel are clear of the load.
- Confirm that when the load is lifted, it will clear all material, machinery, or other obstructions in the area.

6.3 Safety Rules for Operating the Hoist

- **DO NOT** engage in any activity that will divert the attention of the operator.
- **DO NOT** lift, lower, or transport a load and hoist until the operator and all other personnel are clear of the load and the path of the load.
- Confirm that the load a hoist will clear all obstacles before moving or rotating the load.
- Avoid moving loads over personnel.
- **DO NOT** lift, lower, or transport personnel by the hoist, trolley, hoist hook, or load.
- Slowly inch the hook into engagement with the load to eliminate wire rope slack and reduce impact loading of the hoist.
- Avoid unnecessary inching and quick reversals of direction.
- Only lift the load a few inches to confirm that the load is properly balanced before continuing with the lift.
- Only lift the load a few inches to confirm the hoist braking system is functioning properly before continuing with the lift.
- Avoid swinging of the load or hoist hook when the hoist is travelling.
- Avoid sharp contact between trolleys or between trolleys and stops.
- **DO NOT** use hoist limit switches or devices as a normal means of stopping the hoist.

6.4 Safety Rules for Parking the Load

- **DO NOT** lower a load with the hoist until the operator and all other personnel are clear of the load and the path of the load.
- Confirm that the load will clear all obstacles before lowering the load.
- Block loads before landing if slings or other lifting devices must be removed from under the landed load.
- Exercise care when removing a sling from under a landed and blocked load.
- **DO NOT** leave a suspended load unattended unless specific precautions to prevent the load from inadvertently lowering have been instituted and are in place.
- Position the hoist load block and hook above head level for storage when the hoist is not in use.

6.5 Safety Rules before Each Shift

- Visually inspect the load chain for nicks, gouges, and any type of deformation or damage to the load chain. Check for lubrication of load chain.
- Visually inspect the hooks for nicks, gouges, deformation of the throat opening, and wear on saddle or load bearing point and twisting.
- Visually inspect the hook latches for proper operation or damages that do not allow proper operation.
- Replace warning labels if missing or illegible.
- Report any damage or malfunctions to the supervisor.
- **DO NOT** operate the hoist if any damage or malfunctions exist.
- **DO NOT** operate the hoist if it is tagged with an out of order sign.

7.0 INSPECTION

All ACI hoists are inspected and tested at the factory. Regular in-service inspection and preventative maintenance programs not only help reduce overall maintenance costs but may also prevent service shutdowns by forewarning of problems that could arise and cause a shutdown. Regular inspections, periodic minor adjustments, regular cleaning, lubrication, and replacement of worn parts can help maintain the hoists performance and operation in good order.

Hoists shall be maintained, inspected and tested in accordance with this manual and in accordance with the intervals and requirements of ASME B30.16. Cranes shall be maintained, inspected and tested in accordance with the manual furnished by the crane manufacturer and in accordance with the intervals and requirements of, as applicable, ASME B30.2, ASME B30.11, or ASME B30.17. The following definitions are from ANSI/ASME B30.16 and pertain to the inspection procedures below.

- **Designated Person** – a person selected or assigned as being competent to perform the specific duties to which he/she is assigned.
- **Qualified Person** – a person who, by possession of recognized degree or certificate of professional standing, or who, by extensive knowledge, training and experience, has successfully demonstrated the ability to solve or resolve problems relating to the subject matter and work.
- Definitions of service from ASME B30.16 are as follows:
- **Normal Service** – service which involves operation of the hoist with randomly distributed loads within the rated load limit, or uniform loads less than 65% of rated load, for not more than 25% of the time for a single work shift.
- **Heavy Service** – service which involves operation within the rated load limit which exceeds normal service.
- **Severe Service** – service which involves normal to heavy service with abnormal operating conditions.

7.1 Prior to Maintenance or Inspection

Before maintenance or inspections are performed on a hoist, trolley or crane the following precautions shall be taken as applicable.

- The hoist, trolley, or crane to be inspected, tested or repaired shall be run to a location where it will cause the least interference with other hoists, cranes and operations in the area.
- If a load is attached to the hoist hook, it shall be landed.
- All controllers shall be placed in the off position.

- If the hoist is trolley suspended, the trolley shall be blocked to prevent trolley movement.
- If the hoist is installed on a crane, the crane shall be blocked to prevent crane movement.



Hazardous voltages are present in the control box, other electrical components and connections between these components.

The main switch (disconnect) of the hoist, crane or lifting system shall be de-energized. Lock and tag the main switch in the de-energized position in accordance with ANSI Z244.1.

- Warning signs and barriers shall be utilized on the floor beneath the hoist, crane or lifting system where overhead maintenance, repair or inspection work creates a hazardous area on the floor beneath the hoist, crane or lifting system.
- If the crane runway or monorail remains energized because other hoists or cranes are on the same runway or monorail are in operation, rail stops or a signal person(s) shall be located full-time at a visual vantage point for observing the approach of an active hoist(s) or an active crane(s) to prohibit contact by the active hoist(s) or crane(s) with the idle hoist or crane, persons performing maintenance, repair or inspection and equipment used in performing maintenance, repair or inspection.
- A guard or barrier shall be installed between adjacent runways for the length of the established work area to prevent contact between persons performing maintenance, repair, or inspection and a crane on the adjacent runway.
- Safe Access to the hoist, crane or lifting system, such as, scaffolding, work platforms, etc., shall be provided for personnel that will perform maintenance, repair or inspection. If personnel are required to work at elevations in excess of 6 feet above floor or ground level, a fall prevention policy and procedures shall be developed, documented and implemented by the owner/user.
- After maintenance, repair, or inspection work is completed, and before the hoist, crane or lifting system is returned to normal operation:
 - Any guards on the hoist, crane or lifting system that were removed to perform maintenance, repairs or inspection work shall be reinstalled.
 - Any safety devices on the hoist, crane or lifting system that were deactivated to perform maintenance, repair or inspection work shall be reactivated.
 - Any parts that were replaced and other loose material shall be removed.
 - All equipment used in the maintenance, repair or inspection work shall be removed.
- Warning signs, barriers and guards shall be removed only by authorized personnel.
- Lock and tag on the main switch (disconnect) of the hoist, crane or lifting device shall be removed only by the person that locked and tagged the main switch originally, or an authorized person.

7.1.1 Inspection Records

Dated inspection reports and records of the condition of critical components such as load chain, hooks and brakes observed during frequent and periodic inspections should be established. This record should also record replacement, maintenance and repair information. Use of this recorded information will allow a preventative maintenance program to be established for replacement of wearing components on a regular basis, thereby eliminating or reducing

unscheduled downtime situations. These records should be stored where they are available to personnel involved with the inspection, maintenance, or operation of the hoist.

7.2 Inspection Classification

Many factors influence the inspection and preventative maintenance programs required for the hoist. Frequency and severity of service and material handled, local environmental conditions and various applicable codes are some of the factors that the user must consider and adjust the inspection and maintenance programs outlined in this section to meet the specific conditions.

Inspection procedure for hoists in regular service is divided into two general classifications as outlined in ASME B30.16. These two general classifications are based upon the intervals at which the inspections should be performed. The intervals are dependent upon the nature of the critical components of the hoist and the degree of exposure the hoist components and parts to wear and deterioration. The degree of exposure is dependent upon hoist activity and severity of hoist service. Environmental conditions in which the hoist operates are also important considerations for the user when

adjusting hoist inspection and maintenance programs to local conditions. Frequency of inspection and maintenance must be increased if hoist is subjected to severe atmospheric environmental conditions, such as corrosive vapors, extreme heat or cold, cement or dust and other airborne contaminants. The user should carefully consider all environmental conditions and adjust frequency and degree of maintenance for his/her local conditions. Various codes also regulate inspection and maintenance programs. Attention must be given to applicable federal standards, OSHA regulations, national standards, state and local codes which may include mandatory rules relating to hoist inspection and maintenance. The user should become familiar with all applicable codes for his area and be guided accordingly.

These two general classifications of hoist inspections are designated as frequent and periodic. In addition, daily inspections are required to be performed by the operator at the start of each shift or at the time the hoist is first used during each shift.

FREQUENT INSPECTION: Frequent inspections are visual inspections and examinations by the operator or other designated personnel with records not required. Nominal inspection intervals are as follows:

- Normal service – monthly
- Heavy service – weekly to monthly
- Severe service – daily to weekly

PERIODIC INSPECTION: Periodic inspections are visual and audio inspections by designated personnel making records of external conditions to provide the basis for a continuing evaluation of the hoist and its components. If the external inspection indicates the need, some disassembly may be required to make a more detailed inspection and examination. Nominal inspection intervals are as follows:

- Normal service – annually
- Heavy service – semiannually
- Severe service – quarterly

The inspection and maintenance intervals outlined in this section are considered a minimum. The recommended minimum inspection and maintenance intervals are based on average daily use in a normal environment.

Perform these inspections regularly as scheduled and additional inspections as may be required for activity, service and environment of the hoist. The hoist operator must be responsible for determining the operating conditions and severity of service.

WARNING

The inspection intervals listed above are nominal recommendations for reference purposes only. They are based on single shift operation under normal operating conditions and normal environmental conditions. Actual operating and environmental conditions should be reviewed by a qualified person and inspection intervals established on the recommendations of the qualified person.

7.3 Daily, Frequent & Periodic Inspections

Required daily inspection items to be performed by the operator at the start of each shift, or before the hoist is first used during each shift are shown in Table 7.3.1.

WARNING

If any damage or malfunctions are noted by the daily inspection items of Table 7.3.1, the operator shall not operate the hoist and shall immediately advise the supervisor so corrective action may be taken. If the hoist is tagged with an out of order sign, the operator shall not operate the hoist.

Hoist operators should be trained to be aware of malfunctions of the equipment during operation, and to immediately stop operation if such malfunctions occur and to immediately advise the supervisor so corrective action may be taken.

Recommended items to be checked for deficiencies or damage during frequent and periodic inspections are shown in Table 7.3.1. Detailed inspection procedures for some items will be found in specific sections of this manual. These inspections may be performed with the hoist in its normal location and do not require that the hoist be disassembled. Covers and other items normally supplied to allow inspection of components should be opened or removed for these inspections. Any deficiencies or damage such as those listed in Table 7.3.1 shall be examined by a designated person to determine whether they constitute a hazard, or whether any disassembly is necessary for a more detailed examination. The hoist operator should make observations during regular operation for any deficiencies or damage that might appear between inspections.

The list of items in Table 7.3.1 is based on those listed in ANSI/ASME B30.16 for the Frequent and Periodic Inspection. In accordance with ANSI/ASME B30.16, these inspections are not intended to involve disassembly of the hoist. Rather, disassembly for further inspection would be required if frequent or periodic inspection results indicated to do so. A qualified person, trained in the disassembly and re-assembly of the hoist, should only perform such disassembly and further inspection.

Table 7.3.1

Item	Daily	Frequent	Periodic	Inspection Points	Action
Tagged Hoist/Trolley	✓	✓	✓	Check that the hoist/trolley is not tagged with an out of order sign.	Do not operate hoist until an authorized person has repaired and cleared the hoist for operation.
Control Devices	✓	✓	✓	Check that the travel motions match with the control device markings. When checking hoist travel motion, always use the lifting/UP control first.	Repair or replace as required.
Upper Limit Switch	✓	✓	✓	Check that the upper limit switch stops the lifting motion of the hoist load block before striking any part of the hoist or crane.	Repair or replace as required.
Lower Limit Switch	✓	✓	✓	Check that the lower limit switch stops the lowering motion of the hoist hook with a minimum of 9 links of load chain on the unloaded side of the hoist.	Repair or replace as required.
Hook	✓	✓	✓	Check for damage, cracks, nicks, gouges, deformation of the throat opening, wear on saddle or load bearing point and twist.	Replace.
Hook Latch	✓	✓	✓	Check that the hook latch is not missing and that it operates properly.	Replace.
Load Chain	✓	✓	✓	Check for nicks, gouges and any type of deformation or damage to the load chain. Check for lubrication of the load chain.	Lubricate or replace.
Motor Brake Mechanism	✓	✓	✓	Check that the hoist and trolley motions do not have excessive drift or slippage.	Adjust, repair or replace as required.
Mechanical Brake	✓	✓	✓	Check that the braking distance with a rated capacity does not exceed 3% of the lifting speed, approximately 2 chain links.	Repair or replace as required.
Oil Leakage	✓	✓	✓	Check for any sign of oil leakage on the hoist and on the floor area beneath the hoist.	Repair or replace as required.
Unusual Sounds	✓	✓	✓	Listen for any unusual sounds from the hoist and hoist mechanism while operating the hoist.	Adjust, repair or replace as required.
Reeving/Parting	✓	✓	✓	Check that the load chain is properly seated in the reeving/parting and that the load chain and associated parts are not twisted around each other.	Replace.
Capacity & Warning Label	✓	✓	✓	Check that the capacity, warning and other safety labels are not missing and are legible.	Replace.
Control Device Markings	✓	✓	✓	Check that the control device markings are not missing and legible.	Replace.
Fastening Devices		✓	✓	Check that the fastening devices are properly secured (tightened) and that there are no damage or missing parts.	Tighten or replace as required.
Sheaves		✓	✓	Check for cracks, damage to pockets and excessive wear.	Replace.
Load Block		✓	✓	Check for cracks, damage and distortion.	Replace.
Lubricant Levels			✓	Check the quality and quantity of lubricant levels.	Lubricate or replace.
Trolley Wheels			✓	Check for flat spots and excessive wear.	Replace.
Supporting Structure & Trolley			✓	Check for cracks, damage and distortion.	Repair or replace as required.
Electrical Apparatus			✓	Check for pitting, deterioration, wear and improper operation.	Repair or replace as required.
Wiring & Fittings			✓	Check for loose connections and abraded, cut or nicked insulation and wires.	Tighten, repair or replace as required.

7.4 Hook Inspection

Load hooks on hoists in regular service should be visually inspected daily by the operator. If the hoist is used in multiple shift operations, load hooks should be visually inspected by the operator at the start of each shift or before being used for the first time on each shift. When a visual inspection indicates that a more detailed inspection is required, follow the procedures outlined below. These procedures also apply to scheduled frequent and periodic inspections. Refer to Table 7.4.1 for Hook original dimensions.

- Measure hook throat opening from metal to metal of the hook as shown by dimension “g” in Figure 7.4.1. **DO NOT** measure from latch to metal. Hook must be replaced when throat opening measurement has increased 5% over the original throat opening dimension of a new hook. Refer to Table 7.4.2 for original dimensions and replacement dimensions for throat openings of standard hooks specified for the ACI electric chain hoist line. To aid in measuring the throat opening, it is recommended the hoist owner/user make a gage of the dimensions shown in Table 7.4.2. This will allow quick measurement of the throat opening and immediate indication that the hook replacement is required.
 - If the electric chain hoists are specified with special hooks not covered in Table 7.4.1, the hook throat opening should be measured by the owner/user prior to installing the hoist. This will establish a reference point to use in future inspections for determining when the throat opening dimensions have increased by 5% thus requiring the hook be replaced. A gage similar to the one discussed above is recommended. The gage should have the throat opening dimension measured prior to installation, and a dimension 5% greater than the throat opening dimension measured prior to installation.
- Measure Hook depth at the load bearing point (base, bowl or saddle) of the hook as shown by dimension “c” in Figure 7.4.1. The hook must be replaced when wear at load bearing point has decreased the original depth of the hook load bearing point by 5%. Refer to Table 7.4.2 for original dimensions and replacement dimensions for depth at load bearing point of standard hooks specified for the ACI electric chain hoist line.
 - If the electric chain hoists are specified with special hooks not covered in Table 7.4.1, the hook depth at the load bearing point should be measured by the owner/user prior to installing the hoist. This will establish a reference point to use in future inspections for determining when the wear at the load bearing point has decreased the original depth by 5%, thus requiring hook replacement.

Table 7.4.1 Hook Dimensions

Capacity*		a*	b*	c*	d*	e*	g*
1/4	1/2	1.02	0.75	1.02	0.75	1.3	1.1
1		1.34	0.94	1.3	0.94	1.65	1.18
2		1.81	1.22	1.69	1.18	1.93	1.57
3		2.2	1.42	1.97	1.42	2.32	1.89
5		2.64	1.61	2.24	1.61	2.36	1.89
7 1/2		3.43	2.36	3.31	2.36	3.35	2.76

*Capacity in tons & measurements in inches

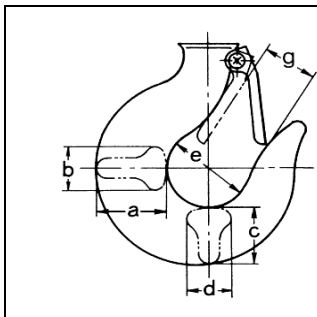
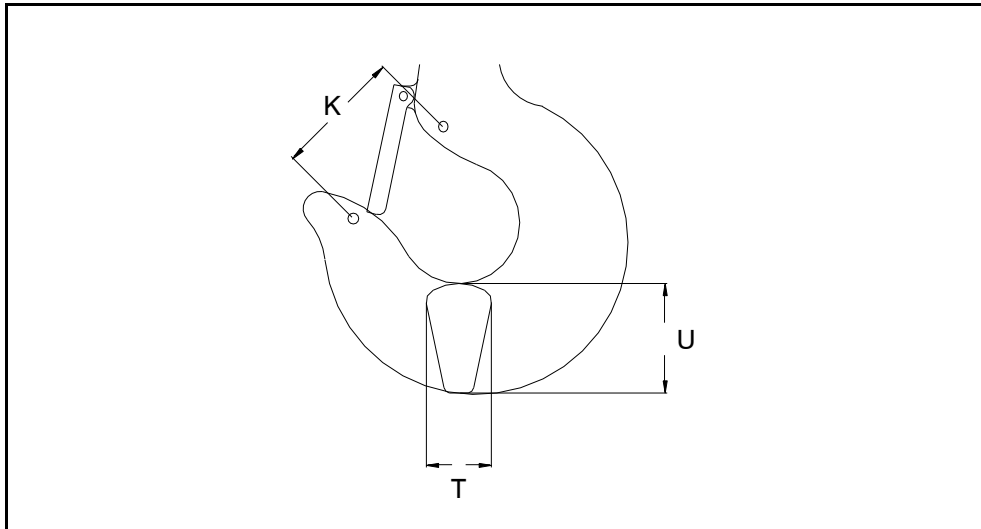

Table 7.4.2
Top and Bottom Hook Throat Opening and Depth Replacement Dimensions



Capacity	K (Nominal)		U		T	
	Standard	Discard	Standard	Discard	Standard	Discard
1/4	2.14	2.25	1.14	1.20	0.91	0.96
1/2						
1						
2	2.64	2.77	1.61	1.69	1.22	1.28
3	2.98	3.13	1.89	1.98	1.34	1.41
5	3.75	3.94	2.36	2.48	1.77	1.86
10	4.35	4.57	3.74	3.93	2.36	2.48

All measurements in inches.
Per ANSI 30.10 Hoists - Replace hook with 5% or more change in throat (K) dimension.

K Measured When New

Top Hook: Bottom Hook:

- A bend or twist exceeding 10° from the plane of the unbent hook requires the replacement of the hook.
- A hook latch, when required, that is missing shall be replaced
- A hook latch, when required, that is inoperative shall be repaired or replaced.
- Hooks having damage from chemicals, corrosion or deformation shall be repaired or replaced. Damage in the form of cracks, nicks and gouges may be repaired by a designated person by grinding longitudinally, following the contour of the hook, providing no dimension of the hook is reduced by more than 5% of the original dimension of a new hook. If the repair reduces the dimension of the hook by more than 5% of the original dimension of a new hook, the hook shall be replaced.

NOTICE

Any hook that requires replacement because of excessive bends, twists or throat opening indicates abuse or overloading of the hoist therefore, other load supporting components of the hoist should be inspected for possible damage when such conditions are found.

CAUTION

Never repair hooks by welding or reshaping. Heat applied to the hook will alter the original heat treatment of the hook material and reduce the strength of the hook.

CAUTION

Never weld handles or other attachments to the hook. Heat applied to the hook will alter the original heat treatment of the hook material and reduce the strength of the hook; if handles or other attachments are required on the hook, contact ACI or the distributor of the hoist.

CAUTION

DO NOT use cotter pins, groove pins or locknuts that have been removed during disassembly. They may be damaged during removal and will not function properly if reused. Always install hook nuts using new cotter pins.

7.5 Limit Switch Inspection

ACI hoists are equipped with a rocker type limit switch (see Figure 7.5.1), which are operated by the limit lever and actuator attached to the chain in the raising direction, and an actuator and stopper attached to the chain in the lowering direction. The chain operated limit stop is provided to guard against over travel of the load in either raising or lowering directions, which can cause damage to the hoist.

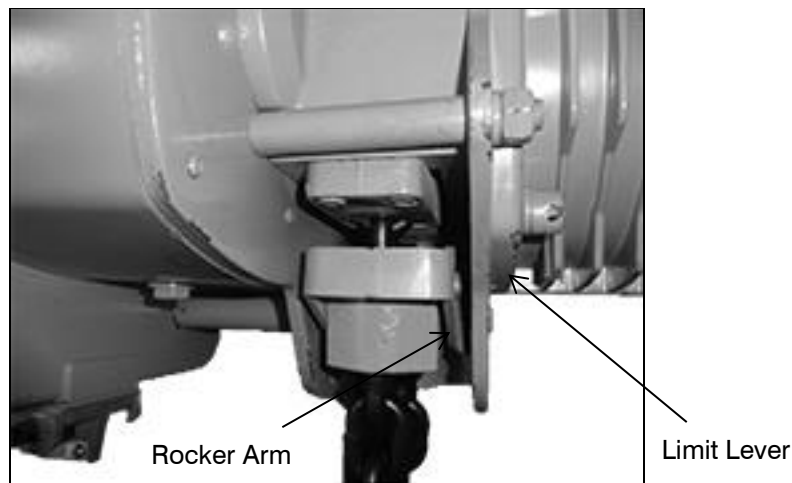

Figure 7.5.1

When the highest position is reached the limit actuator (limit spring) on the load chain, above the hook block, trips the limit lever (see Figure 7.5.2).

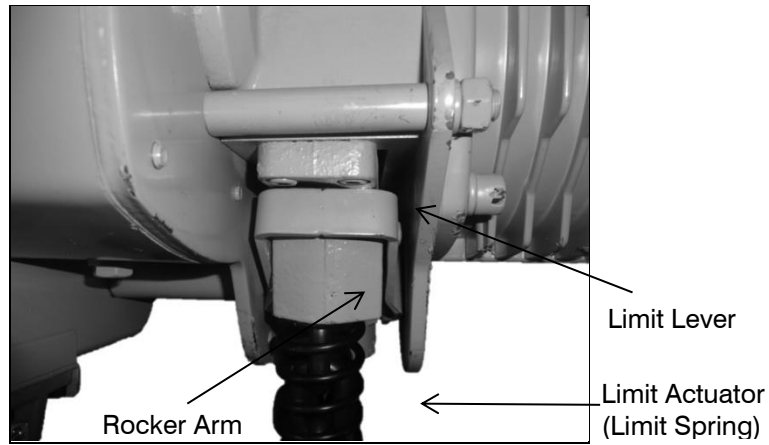

Figure 7.5.2

When the lowest position is reached the limit actuator on the tail end of the load chain trips the limit lever (see Figure 7.5.3).

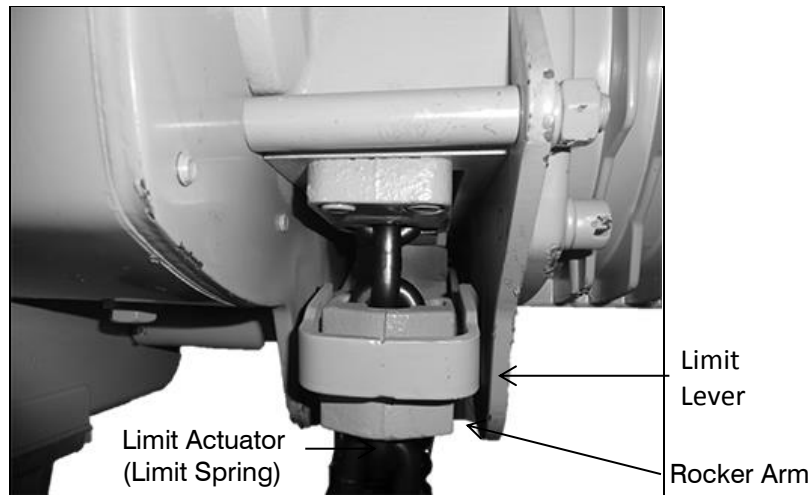

Figure 7.5.3

The limit lever is connected to a limit switch that automatically stops the hoist motor. This is intended as a safety device and is not to be used on a routine basis to stop travel of hook block or to shut off the hoist.

The hoist lower limit device is set at the factory to stop lower travel of the load block with approximately 10 to 15 links of load chain extending beyond the chain guide on the unloaded side of the hoist. It is recommended that the lower limit device be set to prevent the load block from resting on the floor and allowing the load chain to go slack.

The hoist upper limit device is set at the factory to stop hook travel when the load block is approximately 3 inches below the hoist or hoist frame. By changing chain stop location, the limit switch setting can be adjusted. To do this, loosen the two screws holding the chain stopper until the stopper can be released from the chain (see Figure 7.5.4).

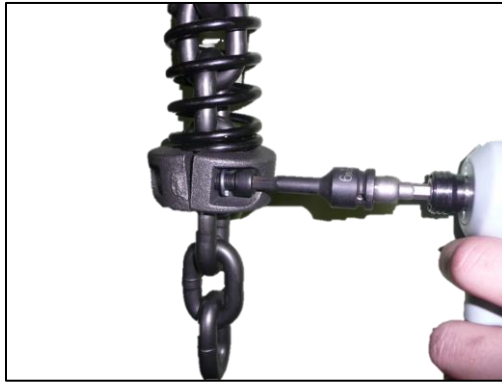

Figure 7.5.4

Install the stopper as follow:

- In some hoist models even when the chain container is used, the free end of the chain is attached to the hoist body as shown in Figure 7.5.5. Depending on the hoist size and capacity, install the chain stopper approximately 7 to 12 links from the free end and make sure the chain remains free of twists.



Figure 7.5.5

- In some other hoist models, the free end of the chain is not attached to the hoist body and the chain stopper is installed on the third link from the free end as shown in Figure 7.5.6.



Figure 7.5.6

7.6 Load Chain Inspection

Load chain on hoists in regular service should be visually inspected daily by the operator. If the hoist is used in multiple shift operations, the load chain should be visually inspected by the operator at the start of each shift or before the first time it is operated on that shift. The daily inspection by the operator is for visual damage to the load chain. Such damage includes nicks, gouges, cracks, wear, twists, kinks, stretch, distortion or deformation, end connections, deposits of foreign material, heat damage and inadequate lubrication. Inspections should also include visual damage to load chain end connections including damaged, worn, loose, or missing end connections. When visual damage is present, the operator shall report such damage to the supervisor and shall not operate the hoist until a more detailed inspection is performed to determine that the chain can be used or the chain is replaced. Detailed inspection procedures are outlined below. These procedures also apply to scheduled frequent and periodic inspections.

WARNING

DO NOT operate a hoist with a chain that shows any sign of damage, deformation, excessive stretch or excessive wear.

The load chain should be inspected during scheduled frequent and periodic inspections; or if the daily visual inspection by the operator indicates a more detailed inspection is required, as follows:

1. Test the hoist with a load on the hook in both lifting and lowering directions. The load chain should feed smoothly into and away from the sheaves or sprockets.
2. If the load chain binds up, jumps or is noisy, check that the load chain is clean and properly lubricated. If the load chain still binds up, jumps or is noisy, clean the load chain and inspect the chain and mating parts for wear, stretch, distortion and other damage.
3. Check the load chain visually for gouges, nicks, weld splatter, carrion, and twisted or distorted links. The existence of any of these conditions is sufficient reason to question continued use of the chain and therefore the chain should be replaced.
4. Check load chain for wear at the inter-link contact points. Slacken the chain and move adjacent links apart to one side to observe and inspect for wear at the contact points. If wear is observed, measure the diameter of the chain link at the wear contact point. Case hardness of chain is about 0.015" deep. Chain must be replaced before the case is worn through. Also check chain for elongation using a Vernier caliper (see Figure 7.6.1).

WARNING

Do not assume that the load chain is safe because it measures below replacement points given herein. Other factors, such as those mentioned in visual checks above may render the chain unsafe or ready for replacement long before elongation replacement is necessary.

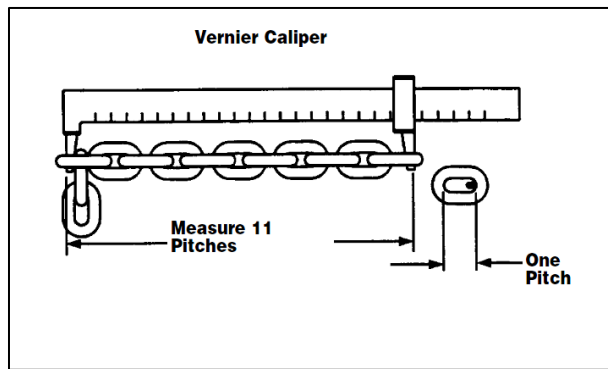

Figure 7.6.1

5. Select an unworn, un-stretched section of chain (usually at slack or tail end) and measure and record the length over the number of chain links (pitches) indicated in figure 7.6.1. Measure and record the same length of a worn section in the load side of the chain. Obtain the amount of wear by subtracting the measurement of the unworn section from the measurement of the worn section. If the result (amount of wear) is greater than the amount specified in the “Allowable Chain Wear” (Table 7.6.1) then the chain has elongated beyond the maximum allowable length and must be replaced.

Table 7.6.1
Allowable Chain Wear

Hoist Capacity*					Number of Pitches to Measure	Max Wear Limit**
1/4	1/2	1	2	3	11	0.138
2						0.196
5	7.5	10				0.221
15		20				

6. Replace chain with excessively pitted, corroded, nicked, gouged, twisted or worn links using only factory approved chain. Replacement load chain must be the same size, grade and construction as the original chain. Never weld or attempt to repair the chain.
7. When the chain is replaced, disassemble the mating parts, such as sheaves, sprockets, guides and stripper for wear and replace as required.
8. Parting of replacement chain must be the same as the original parting of chain on the hoist. Refer to Figure 7.6.2 for parting arrangement of hoists.
9. Replacement chain must be installed without any twist between the hoist and an anchored end on either the loaded or slack (unloaded) side of the driving sheave.

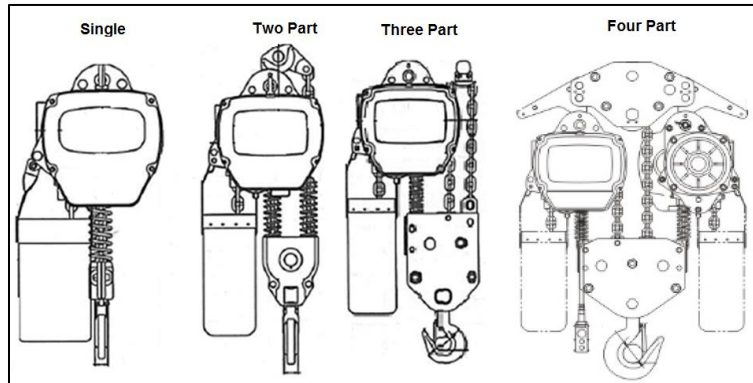

Figure 7.6.2

⚠ WARNING

DO NOT operate a hoist with a twist in the load chain. Operating a hoist with a twist in the load chain can cause the load chain to break and result in serious bodily injury or death and/or property damage.

10. To check the load chain for twists, raise the load block without a load to within three feet of driving load sheave. Check the links. Welds must be away from the driving load sheave grooves and toward the load block sheave grooves.
11. Do not use hoist until replacement load chain has been lubricated. Refer to the lubrication section of this manual.

7.7 Hoist Motor Brake Inspection

The hoist braking system on hoists in regular service should be checked without load on the hook by the operator at the start of each shift, or before the first time the hoist is to be operated during each shift. The hoist braking system should be checked during scheduled frequent and periodic inspection.

During daily, frequent or periodic inspections, the hoist braking system should be checked by operating the hoist in the lifting and lowering directions, without a load on the hook, and stop the hook motion to check operation of the hoist braking system. The hook's drift should not exceed $\frac{1}{4}$ inch in either direction. If the hook drifts exceeds 1.4 inch, the motor brake requires adjustment or the lining requires replacement. Refer to section 8.5 Hoist Motor Brake Adjustment for further details.

The brake lining is designed for a long life and should provide years of trouble free service. If the brake lining is being inspected due to excessive load chain drift during operation, disassemble the motor brake and inspect all motor brake parts. Braking surfaces should be clean, free of grease/oil and should not be glazed. Replace the brake pad assembly and/or motor cover if necessary. For normal inspections, the brake lining should be measured and the motor cover wear should be inspected. Compare the measurement with the values listed in Table 7.7.1. Replace the brake pad assembly if the measurement is smaller than the replacement limit. Refer to section 8.6 Hoist Motor Brake Disassembly.

Table 7.7.1
Hoist Motor Brake Gap Dimensions

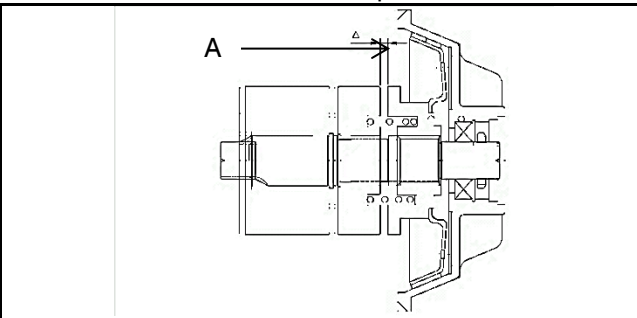

HP	A	Brake Disc Thickness	
	Adjustment Range	Nominal	Replace
1	0.03 - 0.05	0.14"	0.09"
2		0.23"	0.19"
4			

7.8 Trolley Inspection

Trolleys specified for the ACI electric chain hoist line include:

- Push under-running trolleys
- Hand-gearred under-running trolleys
- Motorized under-running trolleys

The trolley should be inspected every three months and during scheduled frequent and periodic inspections as follows:

1. Inspect trolley wheel bearings for wear by manually rotating and rocking wheels. If excessive bearing play is present, replace bearings.
2. Inspect for wear, flat spots or damage to wheel tread and cracked or broken wheel flanges. Replace wheels as required. When wheel replacement is required, all the wheels of a trolley should be replaced.
3. Inspect gear teeth of geared wheels and pinion for wear, cracks or damage. Replace geared wheels or pinion as required. Geared wheels should always be replaced in pairs.
4. Inspect and tighten or replace as required, all bolts, nuts and locking devices.
5. Check lubrication in accordance with the Lubrication section of this manual.

The Trolley brake (if specified) on hoists in regular service should be checked without a load on the hook by the operator. At the start of each shift or the first time the hoist is to be operated during each shift. The trolley brake should be checked during scheduled frequent and periodic inspections.

During daily, frequent or periodic inspections, the trolley brake should be inspected as follows:

- Operate the trolley in both travel directions, without a load on the hook, and stop the motion to check operation of the trolley brake. The drift of the trolley should not exceed a distance equal to 10% of the trolley's travel speed in either direction. If trolley drift exceeds this distance, the motor brake normally requires lining replacement.

- After completing trolley brake lining replacement, operate trolley in both travel directions, without a load on the hook, and stop motion to check operation of the trolley brake. If the trolley drift is still excessive, replace the brake assembly.

The brake lining is designed for a long life and should provide years of trouble-free service. If the brake lining is being inspected due to excessive trolley drift during operation, disassemble the motor brake and inspect all motor brake parts.

Brake surfaces should be clean, free of grease/oil and should not be glazed. Replace the brake assembly and/or motor cover if necessary.

Inspection of the motor brake requires removal of the motor brake unit from the trolley as an assembly. Remove the motor brake as follows:

- Loosen and remove the four screws and spring washers that attach the motor brake end cover to the motor frame.
- Remove the motor cover, brake components and stator (see Figure 7.8.1).



Figure 7.8.1

- Use brake cleaner to remove any lining dust that has accumulated on brake parts (see Figure 7.8.2).



Figure 7.8.2

- Check for loose electrical connections or broken wires. Repair or replace as required.
- Check thickness of brake pad. Replace the brake pad if worn to a thickness of 0.14 inch (3.6 mm) or less.
- Trolley brake is not adjustable.
- After the brake is inspected, carefully place the stator and brake components into the motor frame. Be sure to put back the gasket. Install the motor cover attachment screws.

DANGER

Disconnect power and lockout disconnecting means before adjusting trolley motor brake.

Only qualified personnel should adjust brakes.

7.9 Mechanical Load Brake Inspection

1. Remove the rubber dust cover.



Figure 7.9.1

2. Bend the tabs back on the external tooth washer with a screwdriver.



Figure 7.9.2

3. Remove the bearing nut using the specialized tool depending on the size of your hoist (P/N ECH-MBA-L or ECH-MBA-S).



Figure 7.9.3

4. Remove the external tooth washer.
5. Remove bushing.
6. Remove brake cover nuts using an 8mm allen wrench.



Figure 7.9.4

7. Remove brake cover.
8. Remove cone springs.
9. Remove thrust washer.



Figure 7.9.5

10. Remove brake drum.



Figure 7.9.6

11. Remove brake spring.



Figure 7.9.7

12. Replace only the brake cover, securing in place with the brake cover nuts.

13. Load test the unit using 25-50% load capacity in order to test the integrity of the mechanical load brake. The load brake may slip 3 to 4 chain links.



Figure 7.9.8

14. Reassemble the unit before further use.

7.10 Tests

All new complete hoists, less trolley or trolleys, are load tested by ACI in accordance with ASME B30.16. Hoists furnished in an uncompleted condition (example, less controls, less motor, less load chain, etc.) as hoist components, and winch units are not load tested by ACI. Therefore, it is the responsibility of the owner/user to load test the final lifting system, using such hoist components or winches in accordance with ASME B30.16. If the hoist is installed on a crane, load testing of the crane in accordance with, as applicable, ASME 830.2, ASME B30.11, or ASME B30.17 may be required.

Testing of hoists after original installation is required when the hoist has been altered or repaired; has been idle for a period 12 months or longer; or in accordance with specific testing requirements established by the owner/user. General testing requirements are outlined in ASME 830.16 and should be followed. ASME B30.16 lists two types of hoist tests as follows:

- Operational Test
- Load Test

ASME B30.16 uses the words **SHALL** and **SHOULD** in listing requirements and defines these two words as follows:

- **SHALL** – indicates that the rule is mandatory and must be followed.
- **SHOULD** – indicates that the rule is a recommendation, the advisability of which depends on the facts in each situation.

7.10.1 Operational Test

All altered or repaired hoists, or hoists that have not been used within the past 12 months, **SHALL** be tested by the owner/user before being placed in operational service. The operational test is performed without a load on the hook and includes:

- Operation of control devices.
- Lifting and lowering.
- Operation of brakes.
- Operation and setting of limit switch devices.

Operational test procedures are as follows:

- I. Check hoist travel for correct hook motion to ensure the hoist motor is properly phased. Since motor rotation of a three-phase AC motor can be changed by reversing any two of the lines feeding power to the motor, the direction of hook motion must be checked to verify that it is correct in accordance with the hoist control device markings.
 - **MOMENTARILY** activate the **UP** button of the hoist control device and observe the direction of hook motion. If the direction of the hook travel matches with the direction marking of the hoist control device button activated (example, hook direction is UP when the hoist UP control device button is activated), the hoist motor is properly phased and proceed to step 2. If the direction of the hook travel does not match with the direction marking of the hoist control device button activated, the hoist motor is improperly phased and must be corrected. **DO NOT** use the hoist until motor phasing is corrected.

WARNING

DO NOT attempt to correct an improperly phased hoist by changing the wiring in the hoist control device or the hoist contactors; or by changing the markings on the hoist control device.

Utilize the following steps to correct hoist motor phasing:

1. Disconnect the power, lockout and tagout the power supply before working on the electrical wiring to prevent accidental application of power.
2. Only a qualified person should disconnect or connect the power lines to the hoist.



3. Interchange any two lines supplying power to the hoist.
4. Re-energize power supply to the hoist.
5. Check the hoist travel direction for correct hook motion by pressing **UP** on the hoist control device. If the direction of the hook travel matches the direction marking of the hoist control device button activated then the hoist motor is properly phased. If the direction of the hook travel does not match the direction marking of the hoist control device button activated the hoist motor is improperly phased and must be corrected by repeating steps 1 through 5.

- II. If the hoist has a motorized trolley, check that the trolley travel motion matches the direction marking of the trolley control device button activated.
- o **MOMENTARILY** activate one button of the trolley control device and observe the direction of trolley motion. If the direction of the trolley travel matches the direction marking of the trolley control device button activated (example, the trolley direction is EAST when the trolley EAST control device button is activated), the trolley motor is properly phased. If the direction of the trolley travel does not match with the direction marking of the trolley control device button activated, the trolley motor is improperly phased and must be corrected. **DO NOT** use the trolley until motor phasing is corrected.



DO NOT operate the trolley if direction of the trolley motion does not match the direction marking on the trolley control device button activated.



DO NOT attempt to correct an improperly phased trolley by changing any wiring to the trolley control device or at the trolley contactors; or by changing the markings on the trolley control device.

Utilize the following steps to correct trolley motor phasing:



1. Disconnect the power supply, lockout and tagout the disconnecting means before reconnecting (reversing) power lines to trolley.
2. Only a qualified person should reconnect the power lines to the trolley.

3. Interchange any two lines supplying power to the trolley motor only. **DO NOT** reverse main power leads to the hoist as this will also affect the phasing of the hoist motor.
 4. Re-energize the power supply to the hoist.
 5. Re-check the trolley travel for correct trolley motion. If the direction of the trolley travel matches the direction marking of the trolley control device button activated (example, the trolley travel direction is EAST when the trolley EAST control device button is activated), the trolley motor is properly phased. If the direction of the trolley travel does not match with the direction marking of the trolley control device button activated, then the trolley motor is improperly phased and must be corrected by repeating steps 1 through 5.
- III. Operate hoist in the raising and lowering directions, without a load on the hook, and stop motion to check operation of the motor brake. The hook drift should not exceed $\frac{1}{4}$ inch in either direction. If the hook drift exceeds $\frac{1}{4}$ inch, the motor brake requires adjustment. Refer to the motor brake section of this manual for instructions on motor brake adjustment.

7.10.2 Load Test

All hoists in which load suspension parts have been altered, replaced or repaired **SHALL** be dynamically tested by the owner/user before being placed in operational service. The load test shall be conducted under the direction of a designated person and a record of the test should be made. The test load applied to the hoist shall be at least equal to the rated load capacity of the hoist, or greater as approved by the hoist manufacturer. Functions to be performed during the load test include:

- Operation of control devices.
- Lifting and lowering.
- Operation of brakes.

Load test procedures are as follows:

1. Attach the test load to the hoist hook. The test load **SHALL** be at least equal to the rated load capacity of the hoist. ACI will authorize the use of a hoist test load equal to 125% of the rated load capacity of the hoist for load test purposes only.
2. Before lifting the load, operate the hoist in the lifting direction to take any slack out of the hoist load chain.
3. Lift the load a few inches and stop the hoist. If brakes stop and hold the load, continue lifting and lowering the load several feet, stopping the hoist several times in each direction to check that the hoist braking system stops and holds the load.
4. If the hoist braking system stops and holds the load, the hoist operates in accordance with the control devices and no unusual sounds are present during operation, the hoist is ready to be released for operating purposes.
5. If the hoist braking system does not stop and hold the load, the hoist does not operate in accordance with the control devices or any unusual sounds are present during operation, the hoist is not ready to be released for operating purposes; and corrective action must be taken.

8.0 MAINTENANCE & REPAIR

Repairs include removal of small defects noticed during inspections, such as, damage of the cables or light activities as replacement of the contactors and relays. They do not include technical activities that must be coordinated with the manufacturer, such as, changing the electric diagram or implementation of additional devices.

If maintenance, adjustment, replacement of parts or repair of the hoist is required due to any damage or malfunctions noted during the daily, frequent or periodic inspections outlined in the Inspection section of this manual; due to conditions found during a hoist test as outlined in the Test section of the manual; or based upon specific instructions outlined in other sections of this manual, the hoist shall be taken out of service and maintenance performed as required.

Follow the instructions outlined in various sections of this manual for specific components or portions of the hoist where maintenance or adjustment is required. Refer to the parts identification pages for the specific portion of the hoist where maintenance or adjustment is being performed and to identify and part numbers requiring replacement. If any instructions are unclear; or if any additional information is required in reference to adjustment, maintenance or identification of parts; contact ACI Hoist & Crane or the distributor of the hoist.

8.1 Lubrication

All moving parts of the hoist or trolley for which lubrication is specified should be inspected, checked and lubricated on a regular basis. This section applies to the hoist and trolley only. If the hoist is installed as part of a crane or as part of a lifting system, lubrication instructions covered in the manual furnished by the crane or lifting system manufacturer should be followed.

Hoist and trolley drive unit gear are enclosed and provided a liberal oil reservoir from which gears and bearing inside the hoist are splash lubricated. Check oil level in gear housing periodically with intervals determined by use and operating conditions.

Hoist and trolley machinery must be stationary when inspecting, checking, adding or changing lubricants. The main switch (disconnected) of the hoist, crane or lifting system must be de-energized. Lock and tag the main switch in the de-energized position in accordance with ANSI Z244.1.

Table 8.1.1
Lubrication Chart

Item	Lubrication	Frequency
Trolley Motor Gearbox	*Cosmo No. 3 grease or equivalent.	Every 6 months or 2500 hours.
Trolley Track Wheel & Pinion	Grease or graphite grease.	Monthly.
Load Chain	Lubriplate Bar & Chain Oil 10-R.	Weekly or more frequently, depending on service.
Hoist Motor Gearbox	**SAE 80W/90W lubricating oil.	Check and top off every 6 months. Replace every 3 years.
*Change after first 100 hours of operation. **Change after first 500 hours of operation.		

8.1.1 Hoist Gear Housing

The gear housing cover contains the oil fill hole and eye bolt, check the hole (oil level hole) and plug, as well as the oil drain hole and plug as shown in Figure 8.1.1.1. See Table 8.1.1.1 for oil capacity.

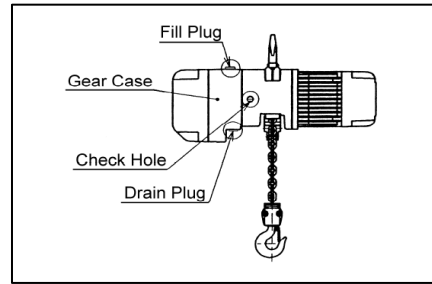

Figure 8.1.1.1

- Check the oil level in the oil level hole. The level of the oil in the housing should be level with the bottom of the oil level hole. If the level of the oil in the housing is below this point, add oil. Add oil through the oil fill hole until oil level in the housing is level with the bottom of the oil level hole.



Figure 8.1.1.2

- When the hoist is shipped from the factory, the oil fill hole is closed by use of an eye bolt in the upper side of the gearbox casing (see Figure 8.1.1.3). **DO NOT** fill above oil level hole, as this will cause oil leakage.

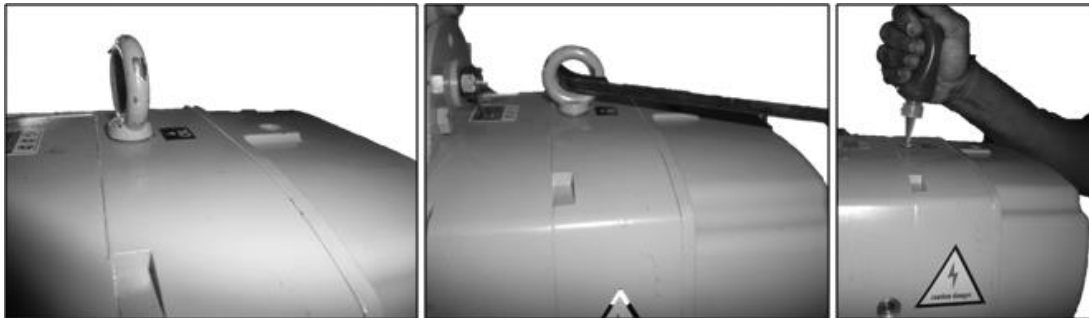

Figure 8.1.1.4

- Removal of oil from the housing is done through the drain hole. The oil drain plug is the bolt in the underside of the gearbox casing. Replace the drain plug and refill the gear case with new oil through the oil fill hole until oil level in the housing is level with the bottom of the oil level hole.
- For normal service, check the hoist gear housing gear oil after 500 operational hours. Thereafter, check oil level every 3 months. Replace the oil more frequently for heavy service or as required by operating environment.

Table 8.1.1.1
Gear Box Oil Capacity

Model	Liters	Quarts
ECH-00518	1.1	1.06
ECH-00526		
ECH-00544		
ECH-01018		
ECH-01026		
ECH-01044		
ECH-02018		
ECH-02026	2.3	2.43
ECH-04009	1.1	1.06
ECH-04013		
ECH-04026	2.3	2.43
ECH-06006	1.1	1.06
ECH-06009		
ECH-06017	2.3	2.43
ECH-10010		
ECH-15007		
ECH-20010	2 x 2.3	2 x 2.43
ECH-30007		
ECH-40005		

8.1.2 Load Chain, Hook & Thrust Bearing

- The load chain should be lubricated after cleaning the load chain with an acid free cleaning solution.
- Apply industrial general lithium grease, NLGI No. 0, to the bearing surfaces of the load chain links.
- Apply the grease to areas of the load chain that contact the load sheave and ensure that grease is applied to the contact areas in the load sheave pockets.
- Machine or gear oil may be used as an alternative lubricant but must be applied more frequently.
- The chain should be lubricated every 3 months, more frequently for heavier usage or severe conditions.
- For dusty environments it is acceptable to substitute a dry lubricant.
- The hook bearings should be cleaned and lubricated at least once a year for normal usage. Clean and lubricate more frequently for heavier usage or severe conditions.
- The suspension pins should be lubricated at least twice per year for normal usage, more frequently for heavier usage or severe conditions.

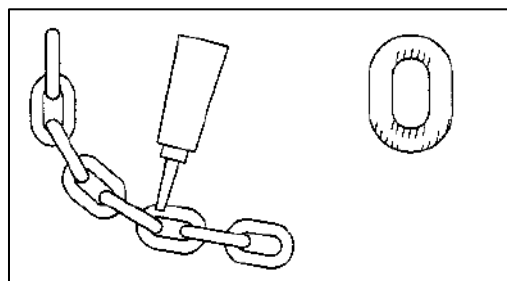

Figure 8.1.2.1

8.2 Chain Maintenance

The load chain should be kept clean and free from any coating or deposits of foreign material which can cause buildup and change link dimensions or reduce the flexibility between chain links. The cleaning process utilized to clean the chain must not damage the chain; any solution used shall be acid-free.

Replacement chain should be stored in a manner to prevent damage or deterioration to the chain.

During installation of chain, care should be exercised to avoid dragging the chain in dirt or around objects that will scrape, nick, cut, crush or induce sharp bends in the chain.

Load chain links articulate slowly under high bearing pressures. The load chain must be lubricated, refer to the Lubrication section of this manual.

8.3 Chain Replacement

Instructions for replacing the load chain on the hoist are outlined below. Parting of replacement load chain must be the same as the original parting of load chain on the hoist. Refer to Figure 8.6.2 for parting arrangement of hoists and section 12.3 for Chain Assembly.

1. Follow the procedures and instructions listed in the Maintenance and Inspection sections of this manual.
2. Remove any load from the hoist hook.
3. Lower hoist hook until lower limit switch stops downward motion of hook.
4. If the hoist is equipped with a chain container, remove the chain container. Refer to Figure 5.2.4.3. If the hoist does not have a chain container, locate the chain support on the hoist body and remove the load chain.

WARNING

DO NOT use cotter pins, groove pins or locknuts that have been removed during disassembly. They may be damaged during removal and will not function properly if reused. **ALWAYS** install load chain using new cotter pins, groove pins or locknuts.

5. Replacement load chain is installed by attaching it to the tail end of the old chain, after disconnecting the old chain from side of hoist frame and removing the limit actuator.
6. Use open “C” links for attaching the new chain to the old chain (see Figure 8.3.1). Links must be identical in size to hoist chain. Refer to Table 8.3.1 for “C Opening Cut Size”. The new chain is then run into the hoist as the old chain is run out. Be certain that all welds on the links of the replacement chain face away from the center of the load sprocket.

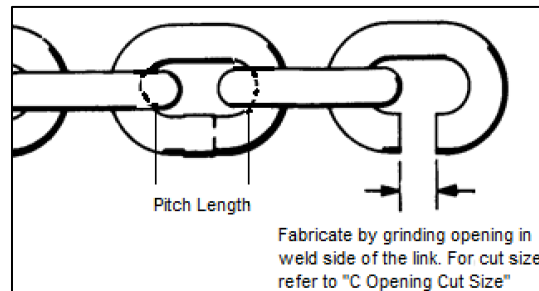

Figure 8.3.1

Table 8.3.1
"C" Opening Cut Size

Capacity*				Pitch Length**	"C" Opening Size**
0.25		0.5		0.75	9/32
1	2	3		0.83	5/16
1.5	2	3		1.18	7/16
2.5	3	5	7.5	1.34	15/32

*Capacity measured in tons.
**All other measurements in inches.

- Remove the hook block assembly and actuator from the old chain and attach them to the replacement chain at the end which was just run through the hoist. Depending on hoist configuration, install limit actuator (chain spring and stopper) on the other end of the chain or connect the end chain to the hoist body.

NOTICE

To avoid serious internal damage to the hoist, when installing the load chain, **DO NOT** attempt to hand feed the chain into the hoist, or use a piece of wire in place of the method described herein. To do so may result in serious internal damage to hoist, as the chain links must be properly seated in the chain sprocket before chain is run into the hoist. Install the chain only as described in this manual.

- If the hoist is equipped with a chain container, reinstall the container. Place the end of the new load chain with the stop into container.
- Examine entire length of the new load chain for twists. Eliminate any twist that is found.
- Test all the limit switches before returning the hoist to regular service.
- Lubricate the new load chain. Refer to the Lubrication section of this manual.

8.4 Overload Limiting Clutch

If abnormal operation or slippage occurs **DO NOT** attempt to disassemble or adjust the overload limiting clutch. Replace the worn or malfunctioning overload limiting clutch as an assembly with a new, factory adjusted part.

8.5 Hoist Motor Brake Adjustment

To keep the hoist working in optimum condition and prevent possible downtime, it is recommended to check the motor brake lining and adjustment at regular intervals.

Inspection and adjustment of the motor brake requires removal of the motor brake unit from the hoist as an assembly. But first, be sure that the power is off, the hoist is unloaded and the load chain is secured.

⚠ DANGER

Before proceeding, disconnect the power supply and make sure the hoist is unloaded. To keep the load chain from moving, secure it by tying together the load and no-load sides directly under the hoist using a cord or wire.

Refer to section 12.1 for Housing & Motor Parts List.

1. Loosen and remove socket head cap screw and spring washers securing the motor shell (see Figure 8.5.1).

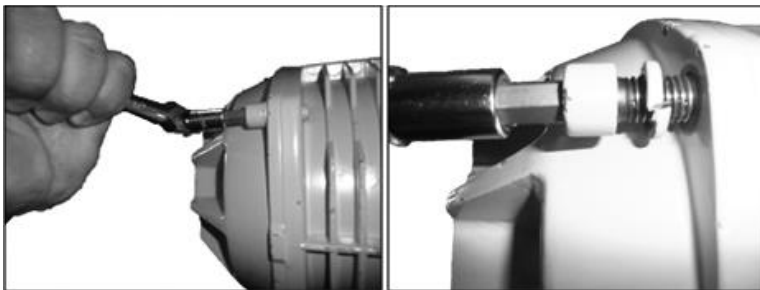

Figure 8.5.1

2. Carefully pull the motor brake unit out of the hoist (see Figure 8.5.2).



Figure 8.5.2

The brake gap is the gap between the brake pad assembly and the brake magnet coil (see Figure 8.5.3).

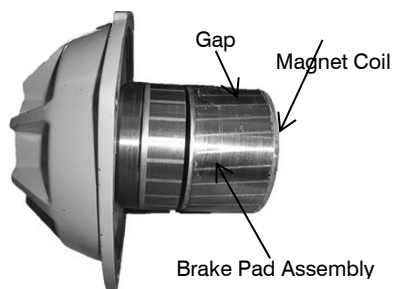

Figure 8.5.3

As the brake disc wears, this gap increases and the brake will not release, and the brake gap will require adjustment. The correct gap is 0.03”-0.05”. Adjustment of the brake gap is accomplished by turning the adjustment nut in the center of the motor cover as follows:

1. Remove the rubber cover (see Figure 8.5.4).



Figure 8.5.4

2. Bend the tab of the lock washer away from the adjusting nut so that the adjusting nut can be rotated (see Figure 8.5.5).

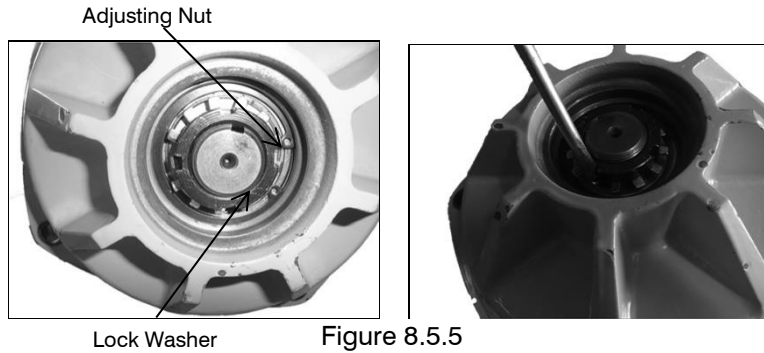

3. Use a brake adjusting tool to rotate the adjusting nut to attain the proper brake gap of 0.03"-0.05" (see Figure 8.5.6).



4. Use a feeler gauge to measure the brake gap (see Figure 8.5.7).



5. After the brake gap is set, secure the adjusting nut by bending one of the tabs of the lock washer into a slot in the adjusting nut. If necessary rotate the adjusting nut clockwise (tightening) to line up the tab with the slot.
6. If the proper brake adjustment cannot be achieved, disassemble the motor brake and inspect all motor brake parts. Replace the brake pad if necessary.

8.6 Hoist Motor Brake Disassembly

1. Loosen and remove socket head cap screw and spring washers securing the motor shell (see Figure 8.5.1).
2. Carefully pull the motor brake unit out of the hoist (see Figure 8.5.2).
3. Remove the rubber cover (see Figure 8.5.4).
4. Bend the tab of the lock washer away from the adjusting nut so that the adjusting nut can be rotated (see Figure 8.5.5).
5. Remove the adjusting nut, lock washer and washer (see Figure 8.6.1).

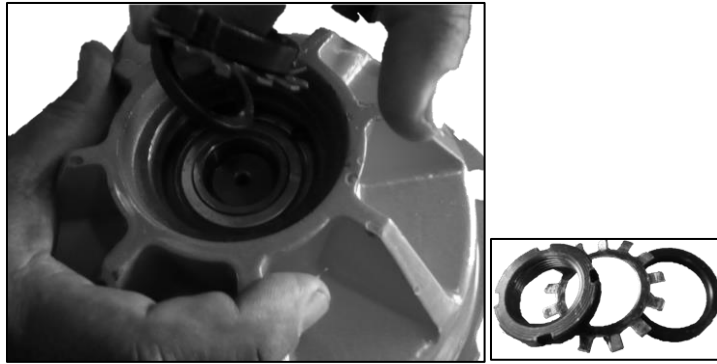
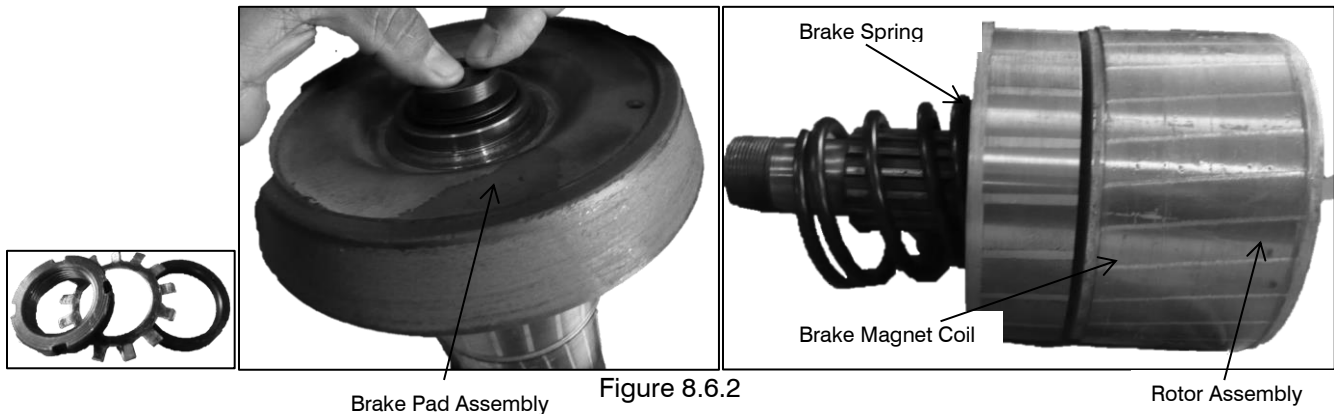

Figure 8.6.1

6. Remove the motor cover.
7. Release the brake pad by pushing the shaft down and removing the washer and plates (see Figure 8.6.2).



8. Inspect all parts. Braking surfaces should be clean, free of grease/oil and should not be glazed. Measure brake gap (see Figure 8.5.7) and brake lining (see Figure 8.6.3) and compare the measurement with the values listed in Table 8.7.1. Replace the brake pad assembly if the measurement is smaller than the replace limit.



Figure 8.6.3

9. After the brake is properly adjusted and inspected, carefully replace the motor brake unit back into the hoist. Reassemble the parts in reverse order of removal.

8.7 Mechanical Load Brake

If abnormal operation or slippage occurs **DO NOT** attempt to disassemble or adjust the mechanical load brake. Replace the worn or malfunctioning mechanical load brake as an assembly with a new, factory adjusted part.

9.0 TROUBLESHOOTING

If the hoist operates erratically, or not at all the hoist should be taken out of service. Any problem should be diagnosed and corrected before the hoist is returned to regular service. Refer to Table 9.1 for some problem areas to consider and investigate.



Disconnect power and lockout/tagout the disconnecting means before performing service to electrical parts of this equipment.

Only a qualified person should perform service to electrical parts of this equipment.

Table 9.1
Troubleshooting Guide

Problem	Possible Cause	Corrective Action
Hoist will not operate.	Power failure in power lines.	Check circuit breakers, switches and connections in power lines. Check power collectors.
	Wrong voltage or frequency.	Check voltage and frequency, or power supply. Check voltage required on motor data plate against power supply.
	No control voltage.	Check transformer fuses. If blown, check for grounding and/or short in the pushbutton station. Check the transformer coil for signs of overheating. Replace transformer if burned out. Verify the transformer secondary is the same voltage as the coils to which it is connected.
	Motor overheated.	Check voltage and frequency, or power supply. They must match with the data on the nameplate.
	Improper, loose or broken wire connection.	Check wiring connections. Check connections in pushbutton station and limit switches.
	Brake does not release.	Check connections and lead wires. Check connections in control devices.
	Control transformer damaged.	Check transformer fuses, coil and open winding.
	Motor burned out.	Replace the motor.
	Faulty VFD.	Check fault codes (see Section 12: Appendix A). Replace as needed.

Table 9.1
Troubleshooting Guide (Continued)

Problem	Possible Cause	Corrective Action
Hook moves in the wrong direction.	Reverse phasing.	Interchange any tow power supply line leads.
	Improper electrical connections.	Check all connections with the wiring diagram
	Faulty VFD.	Check fault codes (see Section 12: Appendix A). Replace as needed.
Hook lifts but will not lower.	Lowering circuit open.	Check circuit for loose connections. Check lower limit switch (if provided).
	Broken conductor in pendant cable.	Check continuity of each conductor in the cable. If one is broke, replace the cable.
	Faulty VFD.	Check fault codes (see Section 12: Appendix A). Replace as needed.
Hook lowers but will not lift.	Lifting circuit open.	Check circuit for loose connections. Check upper limit switch.
	Broken conductor in pendant cable.	Check continuity of each conductor in the cable. If one is broken, replace the cable.
	Low voltage.	Determine the cause of low voltage and correct to within 10% of the specified voltage on the nameplate. Measure voltage at hoist contactor.
	Faulty VFD.	Check fault codes (see Section 12: Appendix A). Replace as needed.
Hoist will not lift rated load or does not have proper lifting speed.	Hoist overloaded.	Reduce the load to within rated capacity of the hoist.
	Low voltage.	Determine the cause of low voltage and correct to within 10% of the specified voltage on the nameplate. Measure voltage at hoist contactor.
	Motor brake not releasing.	Check the brake components.
	Overload limiting clutch slipping.	Contact ACI Hoist & Crane, this adjustment needs to be carried out on a test rig.
Excessive drift when stopping.	Excessive load.	Reduce load to the rated load shown on the nameplate.
	Motor brake not holding.	Check the brake components.
	Motor brake not setting due to insufficient plunger air gap.	Adjust air gap.
Excessive wear of the load chain.	Inadequate lubrication.	Replace load chain and lubricate.
	Side-pulling or abuse.	Replace load chain and avoid improper operation.

Table 9.1
Troubleshooting Guide (Continued)

Problem	Possible Cause	Corrective Action
Hoist motor overheats.	Excessive load.	Reduce load to the rated load shown on the nameplate.
	Excessive duty-cycle.	Reduce frequency of lift.
	Excessive "jogging."	Reduce frequency of jogs.
	Wrong voltage or frequency.	Check voltage and frequency rating on motor data plate against the power supply.
	Damaged motor or worn bearings in motor or hoist frame.	Disassemble the hoist and inspect for worn or damaged parts.
	Motor brake not releasing.	Check the brake components.
	Extreme external heating.	If the ambient temperature exceeds 100°F, frequency of hoist operation must be limited to avoid overheating. Special provisions may be required to ventilate the hoist or shield it from the heat source.
Trolley brake does not release.	Power failure in power lines.	Check circuit breakers, switches and connections in the power lines.
	Improper, loose or broken wire connections.	Check connections and lead wires. Check connections in control devices.
	Wrong voltage or frequency.	Check voltage and frequency rating on motor data plate against the power supply.
	Broken or damaged parts.	Inspect and replace parts as necessary.
Trolley operates in only one direction.	Control circuit broken.	Check for shorted windings in transformer or reversing of contactor coil. A loose connection or broken wire in circuit. Mechanical binding in contactor. The control station switch contacts not making contact. Check continuity and repair or replace defective parts.
	Faulty VFD.	Check fault codes (see Section 12: Appendix A). Replace as needed.
Trolley operates sluggishly.	Excessive load.	Do not exceed the rated load of the trolley.
	Low voltage.	Determine the cause of low voltage and correct to within 10% of the specified voltage on the nameplate.
	Worn or dirty rail.	Clean rails and inspect for worn spots.
	Faulty VFD.	Check fault codes (see Section 12: Appendix A). Replace as needed.

Table 9.1
Troubleshooting Guide (Continued)

Problem	Possible Cause	Corrective Action
Trolley does not track on beam, or bumps as it travels on the beam.	Excessive wear of trolley wheel treads or flat spots on trolley wheel treads.	Inspect trolley wheels and replace as necessary.
Trolley motor overheats.	Excessive load.	Do not exceed the rated load of the trolley motor.
	Low voltage.	Determine the cause of low voltage and correct to within 10% of the specified voltage on the nameplate.
	Extreme external heating.	If the ambient temperature exceeds 100°F, frequency of hoist operation must be limited to avoid overheating. Special provisions may be required to ventilate the hoist or shield it from the heat source.
	Frequent starting or reversing.	Avoid excessive inching, jogging or plugging.
	Phase error.	One line of supply system is grounded or connected. Check for electrical continuity.
	Faulty VFD.	Check fault codes (see Section 12: Appendix A). Replace as needed.
Oil leaks.	Worn or damaged gaskets and/or oil seals.	Replace worn or damaged parts.
	Joints not tight.	Tighten bolts to recommended torque.

10.0 WIRING DIAGRAMS

10.1 Electric Chain Hoist, Hook Mounted (Single Speed)

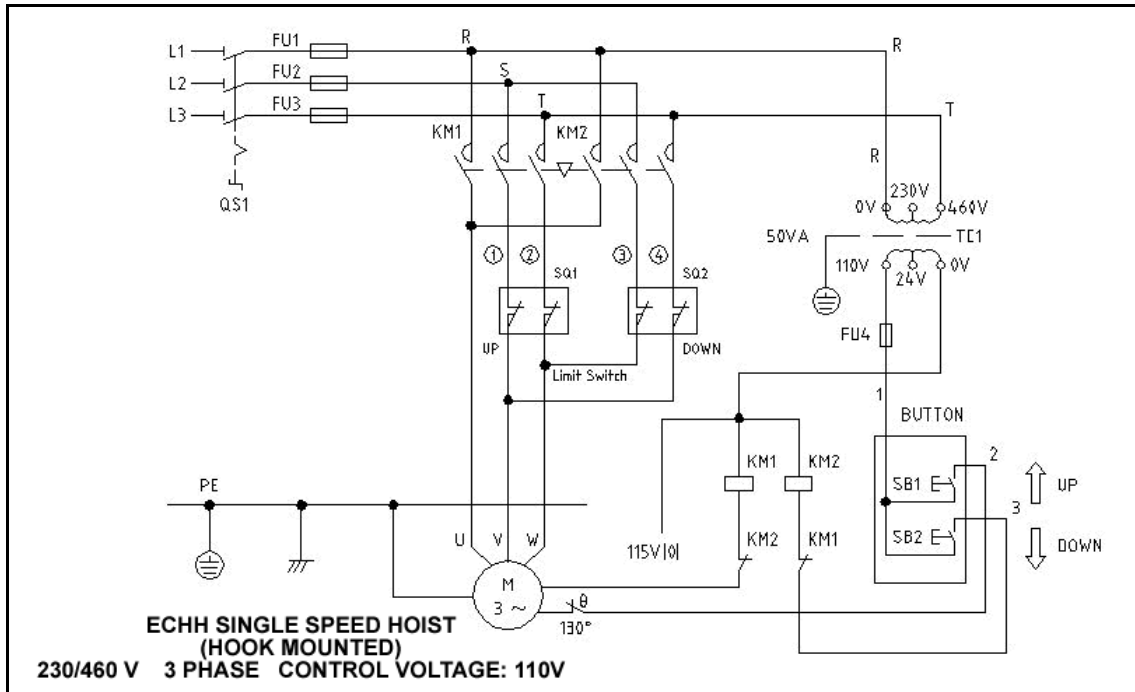

10.2 Electric Chain Hoist with Trolley (Single Speed)

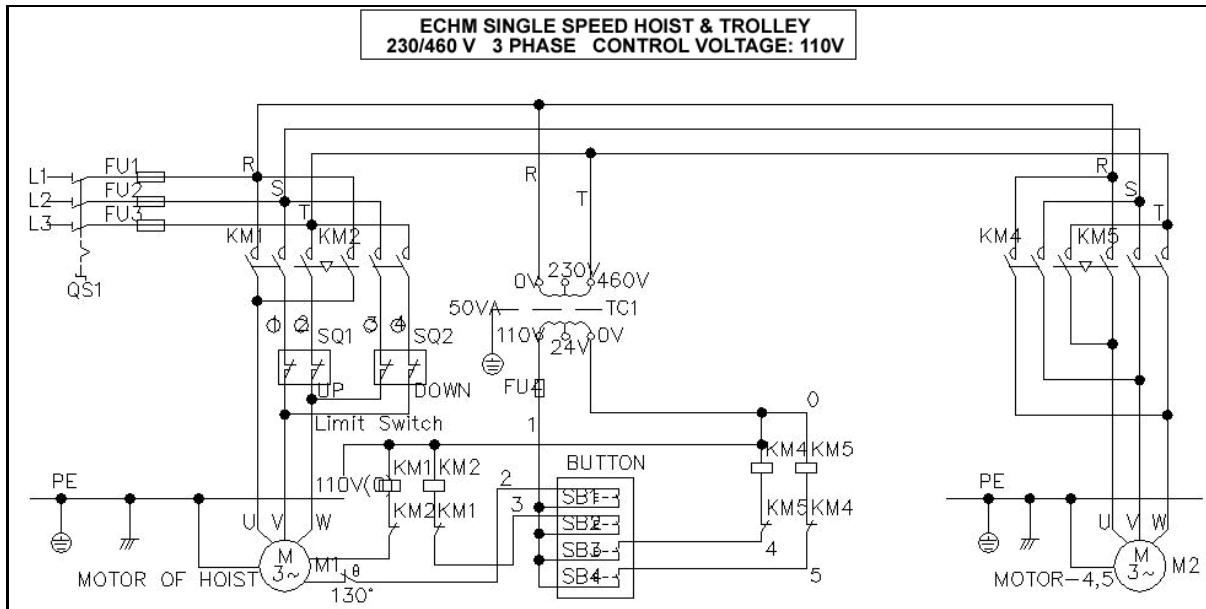

10.3 Electric Chain Hoist Hook Mounted (Dual Speed)

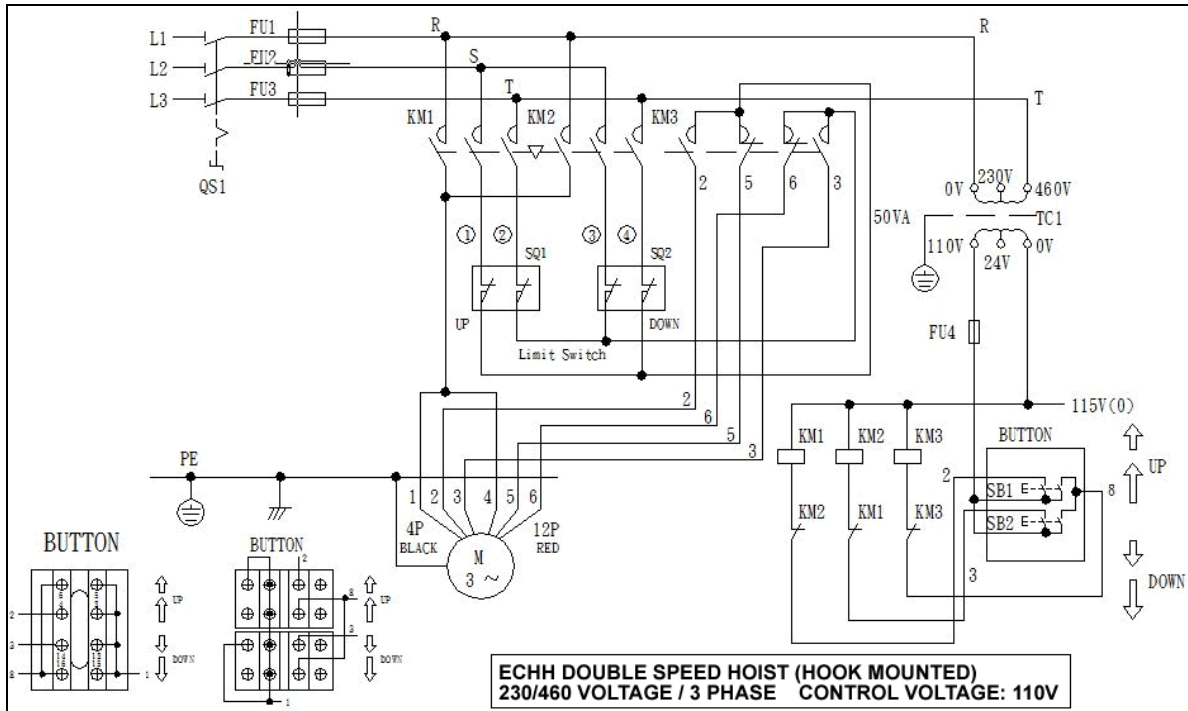

10.4 Electric Chain Hoist with Motorized Trolley (Dual Speed)

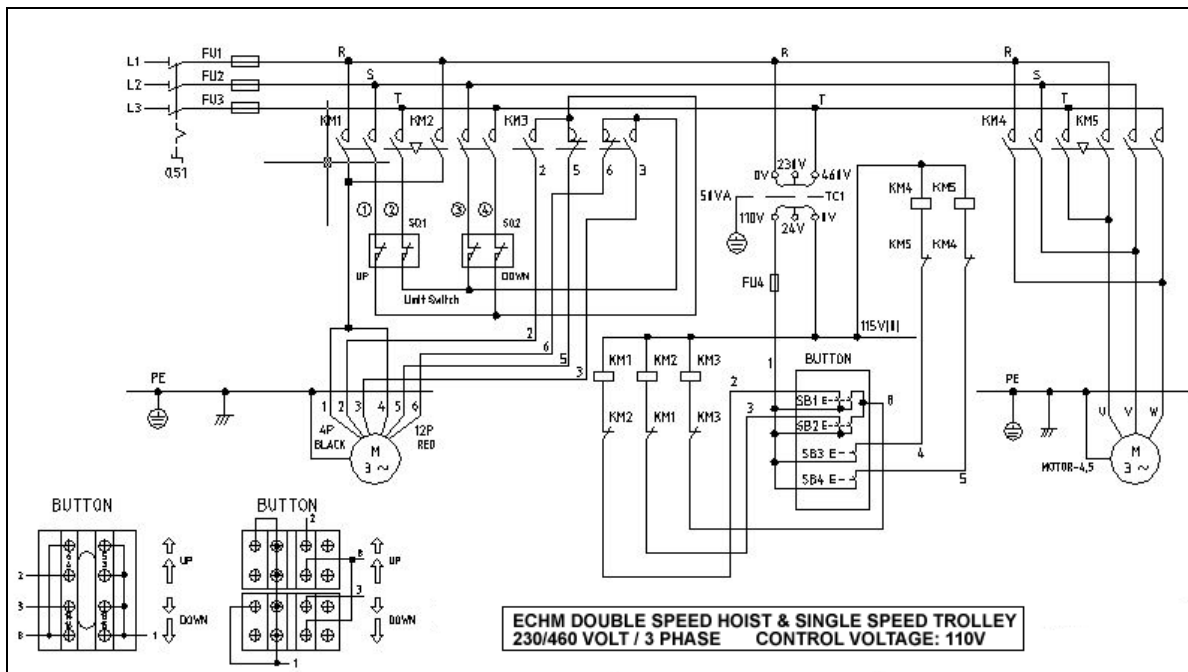

10.5 Motor Connections

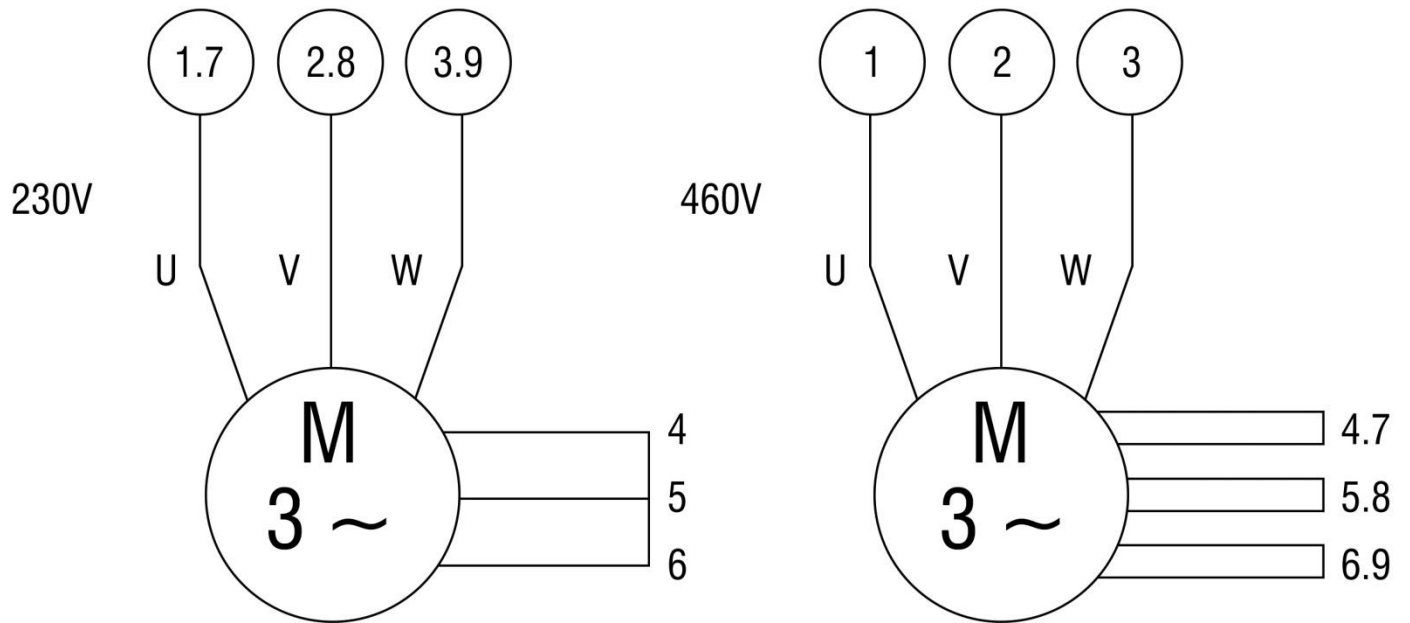

11.0 DIMENSIONS & SPECIFICATIONS

11.1 Hoist Specifications

Table 11.1.1
Specifications of 1/4 to 10 Ton Hoists

Model Number	Capacity (Ton)	Lift Speed (Ft/Min)	Number of Chain Falls	Hoist Motor 3 Ph / 60 Hz		
				HP	Rated Current	
					230 V	460 V
ECHH-00518	1/4	18	1	1.3	8	4
ECHH-00526		26		1.3	8	4
ECHH-00544		44		2.0	10	5
ECHH-01018	1/2	18		1.3	8	4
ECHH-01026		26		1.3	8	4
ECHH-01044		44		2.0	10	5
ECHH-02018	1	18		1.3	8	4
ECHH-02026		26		2.0	10	5
ECHH-04026	2	26		5.0	19	10
ECHH-04009		9		2	1.3	8
ECHH-04013		13	2.0		10	5
ECHH-06017	3	17	5.0	19	10	
ECHH-06006		6	3	1.3	8	4
ECHH-06009		9		2.0	10	5
ECHH-10010	5	10	2	5.0	19	10
ECHH-15007	7 1/2	7	3	5.0	19	10
ECHH-20010	10	10	4	2 X 5.0	2 X 19	2 X 10
ECCH-30007	15	7	6	2 X 5.0		
ECHH-40005	20	5	8			

Table 11.1.2
Hoist with Motor Trolley Dimensions

		1/4 - 5 Ton		7 1/2 Ton		10 Ton		15 Ton		20 Ton	
Model Number	H	A	B	C	D	E	F	Flange Width Range	Approx. Gross Weight (lbs.)		
ECHM-00518	16.5	8	8.5	7.75	16.5	10.5	11	3 - 9.5	303.6		
ECHM-00526											
ECHM-00544											
ECHM-01018											
ECHM-01026											
ECHM-01044											
ECHM-02018											
ECHM-02026	22	10	8.75	8	20	12	13.5	4 - 12.5	528.5		
ECHM-04009											
ECHM-04013	23	8	8.5	7.75	20.75	10.75	11	5 - 10	477.8		
ECHM-06006											
ECHM-06009	29.75	10	8.75	8	20	12	13.5	4 - 12.5	593.5		
ECHM-06017											
ECHM-10010	30.75	11	8.75	6.75	8	20.5	12	13.5	652.5		
ECHM-15007											
ECHM-20010	43	8	8	6.75	39	12	13.5	6 - 12	1408.5		
ECHM-30007											
ECHM-40005	45	7	8	6.75	49.25	12	13.5	6 - 12	2773.5		

* Can change to 3.75" specification modification.
All measurements are in inches.
Based on standard 10 ft. of lift.

Table 11.1.3
 ¼ – 7 ½ Ton Electric Chain Hoist Dimensions

											¼ – 2 Ton (1 Chain)		2 – 5 Ton (2 Chain)		7 ½ Ton (3 Chain)		3 Ton (3 Chain)		Remote Control Detail (If applicable)														
											Single Speed				Variable Frequency Drive																		
Model Number	H*	D	E*	F	G	I	J*	K	L	O	Approx. Gross Weight (lbs)	A	B	C	G	M	P	T	A	B	C	G	M	P	T								
ECHH-00518	20	11.8	7	4.8	6.3	1.4	11.2	0.9	1.3	---	138	21.75	10.7	11	---	---	---	6	25.25	10.7	14.5	---	---	---	6								
ECHH-00526																																	
ECHH-00544																																	
ECHH-01018																																	
ECHH-01026																																	
ECHH-01044																																	
ECHH-02018																																	
ECHH-02026																																	
ECHH-04026	28	16.3	10.25	6.1	7.5	1.6	14	1.23	1.59		280	25.5	12	13.5	---	---	---	6	29.75	12	17.75	---	---	---	6								
ECHH-04009	27.6	12.5	9.4	3.2	8.6	1.6	11.2	1.22	1.5		155	21.5	10.5	11					---	---	---					6	25	10.5	14.5	---	---	---	6
ECHH-04013												27.6															27.6						
ECHH-06006	31.5	15	10	5	9.5	2	11.2	1.35	1.8		240	21.75	10.7	11					---	---	---					6	25.25	10.7	14.5	---	---	---	6
ECHH-06009				3	8.5	2																											
ECHH-06017	35	16.5	10	3.5	8.5	2	14	1.35	1.8		305	25.5	12	13.5					---	---	---					6	29.75	12	17.75	---	---	---	6
ECHH-10010	37			4.5	2.5	1.8	2.07	320																									
ECHH-15007	38.6	18.5	10.5	7.5	---	3	14	2.2	2.8	480	25.5	12	13.5	8.5	1.6	2.94	6	29.75	12	17.75	8.5	1.6	2.8	6									

* Dimensions are based on standard 10 ft. of lift.
 All measurements in inches.
 † Contact us for additional flange width

Electric Chain Hoists (Dual Brake)

Model ECH

ECH-0214

689 SW 7th Terrace, Dania Beach, FL 33004 | (954) 367-6116

Table 11.1.4
10 – 20 Ton Electric Chain Hoist Dimensions

												10 Ton (4 Chain)		15 Ton (6 Chain)		20 Ton (8 Chain)		Remote Control Device (If applicable)															
Model Number	H*	D	E*	F	I	J*	K	L	N	O	Approx. Gross Weight (lbs.)	Single Speed							Variable Frequency Drive														
												A	B	C	G1/G2	M	P	T	A	B	C	G1/G2	M	P	T								
ECHH-20010	39	35.25	17.62	3.8	14	3.1	2.2	2.9	2.62	2.37	810	25.5	12	13.5	1 / 5	35.6	2.8	6	29.75	12	17.75	1 / 5	35.6	2.7	6								
ECHH-30007	39	2.75	26	20.5	4.4	19.1	3.3	3.6	8.3	2.3	1025				25.5	12	13.5					2.87	41	---		6	29.75	12	17.75	2.87	41	---	6
ECHH-40005	41		33.75	28.3			3.1	4.1															49	---						2.8	49	---	

* Dimensions are based on standard 10 ft. of lift.
 All measurements in inches.
 † Contact us for additional flange width

Table 11.1.5
1/4 - 5 Ton Electric Chain Hoist w/ Standard Push Trolley Dimensions

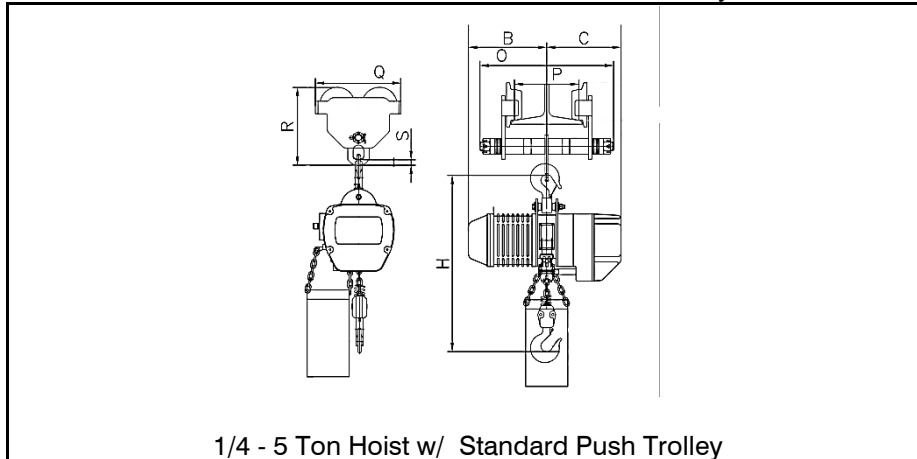

Model Number	H	Q	O	R	S	C	B	P
ECHP-00518	25	8	9.5	8	1.25	11	10.7	1.75 – 5.5
ECHP-00526								
ECHP-00544								
ECHP-01018	26.25	9.68	12.25	7.37	1.5	13.5	12	1.75 – 5.93
ECHP-01026								
ECHP-01044								
ECHP-02018	32.7	10.87	12.87	10.35	1.62	11	10.7	2.75 – 8
ECHP-02026								
ECHP-04009								
ECHP-04013	33.1	13.07	13.5	13	13.5	12	13.5	3.5 – 8
ECHP-04026								
ECHP-06006								
ECHP-06009	39	14.87	14	13.86	13.5	12	13.5	3.93 – 8
ECHP-06017								
ECHP-10010	42.5							4.5 – 8

All dimensions measured in inches.
Based on standard 10 ft. of lift.

Table 11.1.6
1/4 - 5 Ton Electric Chain Hoist w/ Low Headroom Push Trolley Dimensions

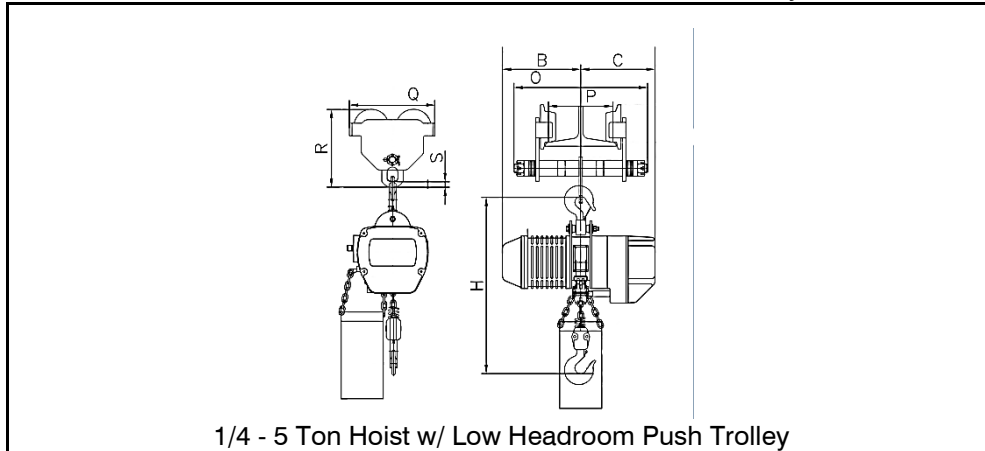

1/4 - 5 Ton Hoist w/ Low Headroom Push Trolley

Model Number	H	Q	O	R	S	C	B	P
ECHP-00518	16.5	4.2	0.5	0.5	16.5	11	10.7	3 - 10
ECHP-00526								
ECHP-00544								
ECHP-01018								
ECHP-01026								
ECHP-01044								
ECHP-02018								
ECHP-02026								
ECHP-04009	22	4.9	0.6	0.6	17.3	13.5	10.5	3.75 - 13
ECHP-04013								
ECHP-04026								
ECHP-06006								
ECHP-06009	23	4.9	0.6	0.6	20.7	13.5	10.7	4 - 10
ECHP-06017								
ECHP-10010								
ECHP-10010	29.75	5.5	0.6	0.6	20	13.5	12	3.75 - 13
ECHP-10010	30.75	5.5			20.5		12	3.75 - 12.5

All dimensions measured in inches.
Based on standard 10 ft. of lift.

11.2 Trolley Specifications

Table 11.2.1
Standard Motorized Trolley

Model Number	Capacity (Tons)	Number of Chain Falls	Trolley Motor					
			50 FPM			100 FPM		
			HP	Rated Current		HP	Rated Current	
				230V	460V		230V	460V
MT-150-3	7 1/2	3	1	1.34	0.68	1	2.13	1.07
MT-200-4	10	4	2 X 1	2 X 1.34	2 X 0.68	2 X 1	2 X 2.13	2 X 1.07
2 X MT-150-3	15	6						
2 X MT-200-4	20	8	4 X 1	4 X 1.34	4 X 0.8	4 X 1	4 X 2.13	4 X 1.07

Table 11.2.2
Low Headroom Motorized Trolley

Model Number	Capacity (Tons)	Number of Chain Falls	Trolley Motor					
			50 FPM			100 FPM		
			HP	Rated Current		HP	Rated Current	
				230V	460V		230V	460V
MT-020-1	1/4	1	0.5	3.1	1.6	0.5	1.53	0.76
MT-020-1	1/2							
MT-020-1	1							
MT-040-2	2	2	1	1.3	0.68	1	2.13	1.07
MT-040-1		1						
MT-060-3	3	3	1	1.3	0.68	1	2.13	1.07
MT-060-2		2						
MT-100-2	5							

Table 11.2.3
Standard Motorized Trolley Dimensions

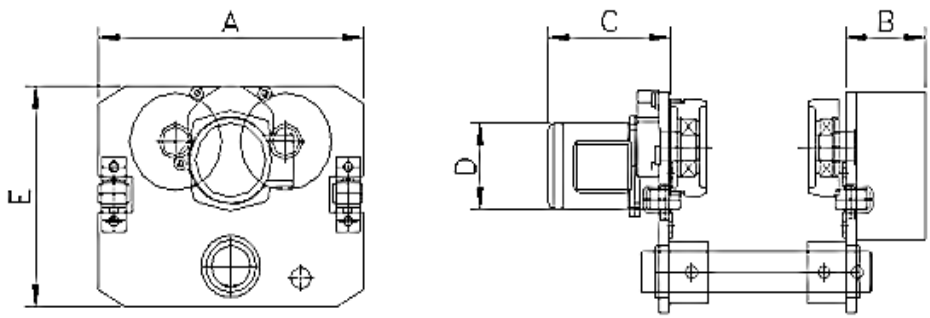

Model Number	A	B	C	D	E	Flange Width
MT-150-3	17.7	12.4	10.6	6.7	14.2	6 - 11
MT-200-4	20.1	14.7	10.9	7.9	15.1	6 - 11
2 x (MT-150-3)	n/a	n/a	n/a	n/a	n/a	n/a
2 x (MT-200-4)	n/a	n/a	n/a	n/a	n/a	n/a

All measurements in inches.

Table 11.2.5
Low Headroom Motorized Trolley Dimensions

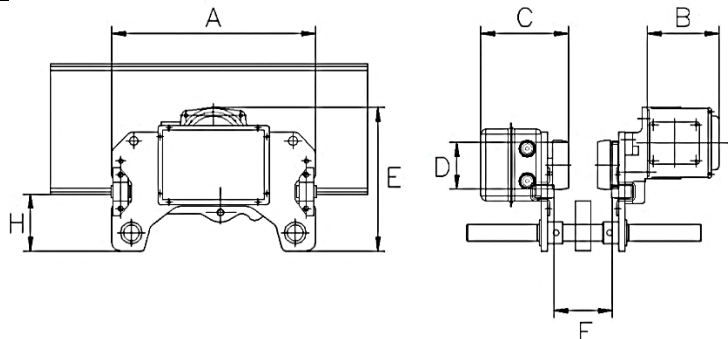

Model Number	A	B	C	D	E	F Flange Width	H
MT-020-1	16.5	6.5	9	4.25	13.12	3-10	5
MT-020-1					12.5		
MT-020-1				5.0	13.3	3.75-13	
MT-040-2	17.3			4.25	12.25	4-10	
MT-040-1	20.0		5.0	13.3	3.75-13	5.5	
MT-060-3	20.7		9.75	5.5	12.75	3.75-12.5	6.25
MT-060-2	20.0						
MT-100-2	20.5						

All measurements in inches.

Table 11.2.6
Low Headroom Push Trolley Dimensions

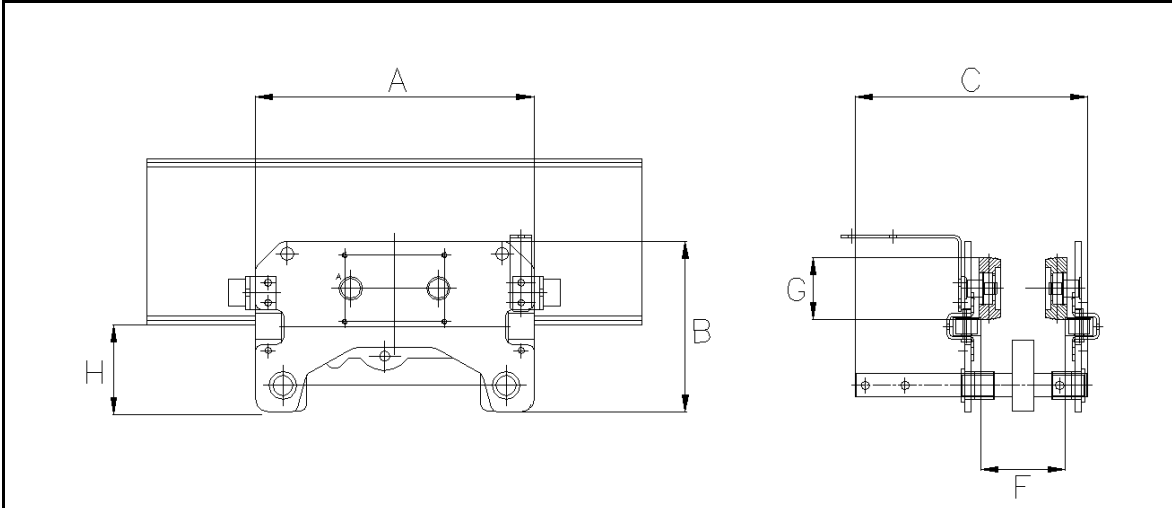

Model Number	A	B	C	F	G	H
PT-005-1	16.5	10.12	14.0	3-10	4.25	5
PT-010-1						
PT-020-1						
PT-040-2	17.32	11	17.0	3.75-13	5.0	5.25
PT-040-1	20					
PT-060-3	20.75					
PT-060-2	20	10.87	16.93	3.75-13	5.0	5.5
PT-100-2	20.5	12.75	15.5	3.75-12.5	5.5	6.25

All measurements in inches.

12.0 EXPLODED VIEWS & PARTS LISTS

12.1 Exploded View: Housing & Motor

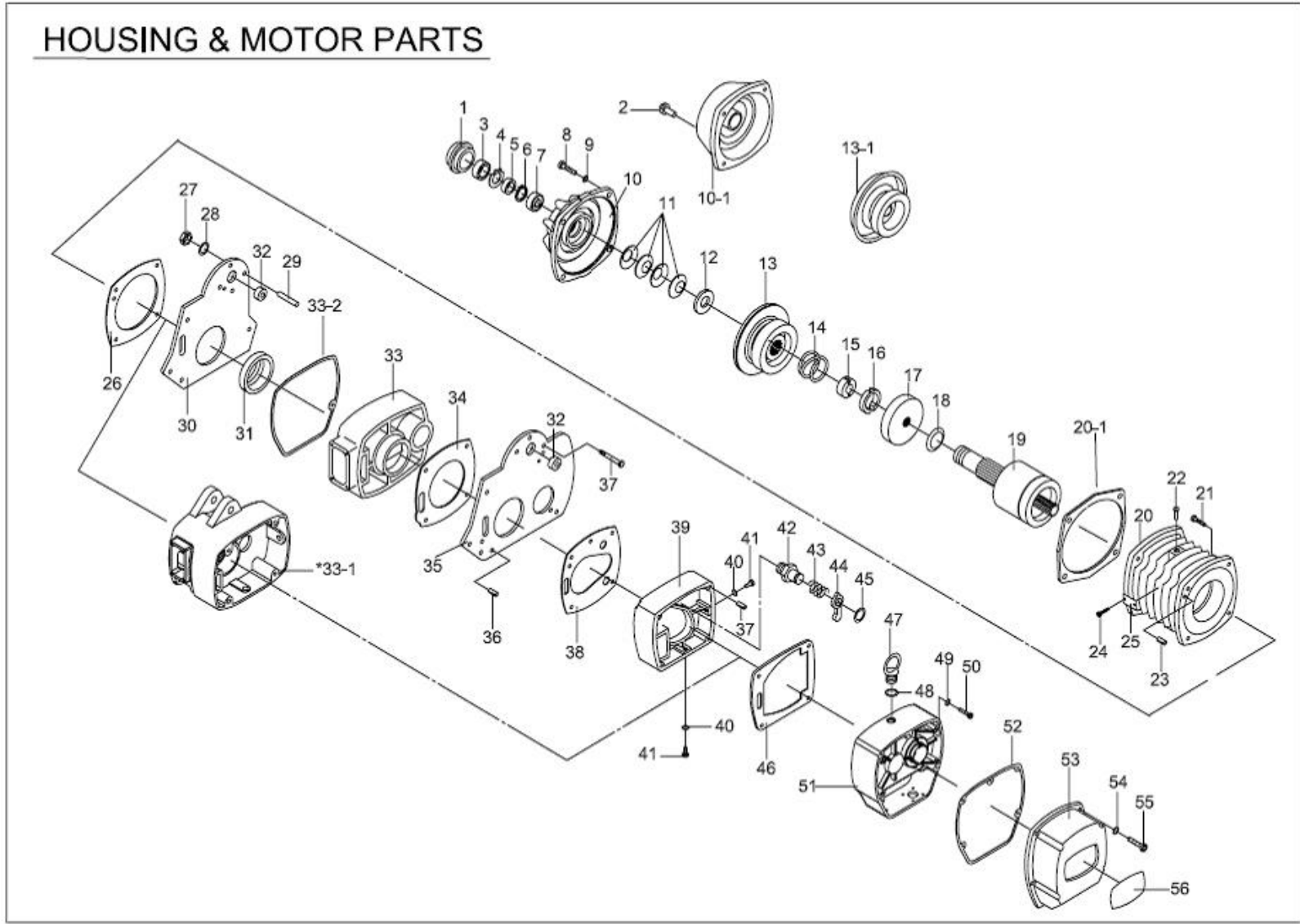

12.2 Parts List: Housing & Motor

Housing & Case		Model Number ECH-															
#	Description	00518	00526	00544	01018	01026	01044	02018	02026	04009	04013	04026	06009	06017	10010	15007	20010
		Part Number															
1	Dust cover	101SKA										101SKB	101SKA	101SKB		101SKB x 2	
2	Dust cap	102SKA										102SKB	102SKA	102SKB		102SKB x 2	
3	Bearing nut	103SKA										103SKB	103SKA	103SKB		103SKB x 2	
4	External toothed washer	104SKA										104SKB	104SKA	104SKB		104SKB x 2	
5	Bush	105SKA										105SKB	105SKA	105SKB		105SKB x 2	
6	Cir clip	106SKA										106SKB	106SKA	106SKB		106SKB x 2	
7	Ball bearing	107SKA										107SKB	107SKA	107SKB		107SKB x 2	
8	Hex socket cap bolt	108SKA x 4										108SKB x 4	108SKA x 4	108SKB x 4		108SKB x 8	
9	Spring washer	109SKA x 4										109SKB x 4	109SKA x 4	109SKB x 4		109SKB x 8	
10	Brake cover (cast iron)	508SKA										508SKB	508SKA	508SKB		508SKB x 2	
10-1	Brake cover (aluminum)	-	D110SL	D110SH	-	D110SL	D110SH	D110SL	D110SH	D110SL	D110SH	D110SB	D110SH	D110SB		D110SB x 2	
11	Cone springs	113SKA x 4										113SKB x 4	113SKA x 4	113SKB x 4		113SKB x 8	
12	Thrust washer	114SKA										114SKB	114SKA	114SKB		114SKB x 2	
13	Brake drum cast iron	507SKA										507SKB	507SKA	507SKB		507SKB x 2	
13-1	Brake drum aluminum	115SKA										115SKB	115SKA	115SKB		115SKB x 2	
14	Brake Spring	116SKA										116SKB	116SKA	116SKB		116SKB x 2	

Housing & Case		Model Number ECH-															
#	Description	00518	00526	00544	01018	01026	01044	02018	02026	04009	04013	04026	06009	06017	10010	15007	20010
		Part Number															
15	Brake magnet locking sleeve	117SKA										117SKB	117SKA	117SKB		117SKB x 2	
16	Brake magnet split ring	118SKA x 2										118SKB x 2	118SKA x 2	118SKB x 2		118SKB x 4	
17	Brake magnet coil	119SKA										119SKB	119SKA	119SKB		119SKB x 2	
18	Cone springs	120SKA										120SKB	120SKA	120SKB		120SKB x 2	
19	Motor rotor and primary shaft	121SKA										121SKB	121SKA	121SKB		121SKB x 2	
20	Motor casing and stator	122SAH	122SAL	122SAH	122SAH	122SAL	122SAH	122SAL	122SAH	122SAL	122SAH	122SKB	122SAH	122SKB		122SKB x 2	
		D122SL	D122SL	D122SH	D122SL	D122SL	D122SH	D122SL	D122SH	D122SL	D122SH	D122SB	D122SH	D122SB		D122SB x 2	
20-1	Gasket	500SKA										500SKB					
21	Hex socket cap bolt	123SKA x 4										123SKB x 4	123SKA x 4	123SKB x 4		123SKB x 8	
22	Spring pin	124SKA										124SKB	124SKA	124SKB		124SKB x 2	
23	Locating spring pin	125SKA x 2										125SKB x 2	125SKA x 2	125SKB x 2		125SKB x 4	
24	Name plate rivet	126SKA x 2										126SKB x 2	126SKA x 2	126SKB x 2		126SKB x 2	
25	Motor name plate rivet	127SKA										127SKB	127SKA	127SKB		127SKB x 2	
26	Gasket B	131SKA										131SKB	131SKA	131SKB		131SKB x 2	
27	Hex nut	-										132SKB x 4	-	132SKB x 4		132SKB x 8	
28	Spring washer	-										133SKB x 4	-	133SKB x 4		133SKB x 8	
29	Sleeve	-										134SKB x 4	-	134SKB x 4		134SKB x 8	
30	Yoke plate B	-										135SKB	-	135SKB		135SKB x 2	

Housing & Case		Model Number ECH-															
#	Description	00518	00526	00544	01018	01026	01044	02018	02026	04009	04013	04026	06009	06017	10010	15007	20010
		Part Number															
31	Bearing seat B						-					136SKB	-		136SKB		136SKB x 2
32	Upper hook bearing bush						-					137SKB x 2	-		137SKB x 2		137SKB x 4
33	Chain wheel case						-					138SKB	-		138SKB		138SKB x 2
33-1	Chain wheel case						506SKA					-	506SKA		-		-
33-2	Gasket																600SKB
34	Gasket C						-					139SKB	-		139SKB		139SKB x 2
35	Yoke Plate A						-					140SKB	-		140SKB		140SKB x 2
36	Locating spring pin						-					125SKB x 2	-		125SKB x 2		125SKB x 4
37	Hex head bolt						-					143SKB x 6	-		143SKB x 6		143SKB x 12
38	Gasket D						-					144SKB	-		144SKB		144SKB x 2
39	Gear case B						-					145SKB	-		145SKB		145SKB x 2
40	O-Ring																146SKA x 4
41	Oil plug (slotted head)																147SKA x 4
42	Ratchet pawl spindle						150SKA					150SKB	150SKA		150SKB		150SKB x 2
43	Torsion spring						151SKA					151SKB	151SKA		151SKB		151SKB x 2
44	Ratchet pawl spindle						152SKA					152SKB	152SKA		152SKB		152SKB x 2
45	Cir clip						153SKA					153SKB	153SKA		153SKB		153SKB x 2
46	Gasket E						154SKA					154SKB	154SKA		154SKB		154SKB x 2
47	Eye bolt & pressure valve						155SKA					155SKB	155SKA		155SKB		155SKB x 2

Housing & Case		Model Number ECH-															
#	Description	00518	00526	00544	01018	01026	01044	02018	02026	04009	04013	04026	06009	06017	10010	15007	20010
		Part Number															
48	O-Ring	157SKA										157SKB	157SKA	157SKB		157SKB x 2	
49	External toothed washer	158SKA x 4										158SKB x 4	158SKA x 4	158SKB x 4		158SKB x 8	
50	Hex socket cap bolt	159SKA x 4										159SKB x 4	159SKA x 4	159SKB x 4		159SKB x 8	
51	Gear case A	510SKA										510SKB	510SKA	510SKB		510SKB x 2	
52	Gasket F	161SKA										161SKB	161SKA	161SKB		161SKB x 2	
53	Electrical section cover	162SKA										162SKB	162SKA	162SKB		162SKB x 2	
54	Spring washer	163SKA x 4										163SKB x 4	163SKA x 4	163SKB x 4		163SKB x 8	
55	Hex socket cap bolt	164SKA x 4										164SKB x 4	164SKA x 4	164SKB x 4		164SKB x 8	
56	Hoist name plate	165SKA										165SKB	165SKA	165SKB		165SKB x 2	

12.3 Exploded View: Gear Case

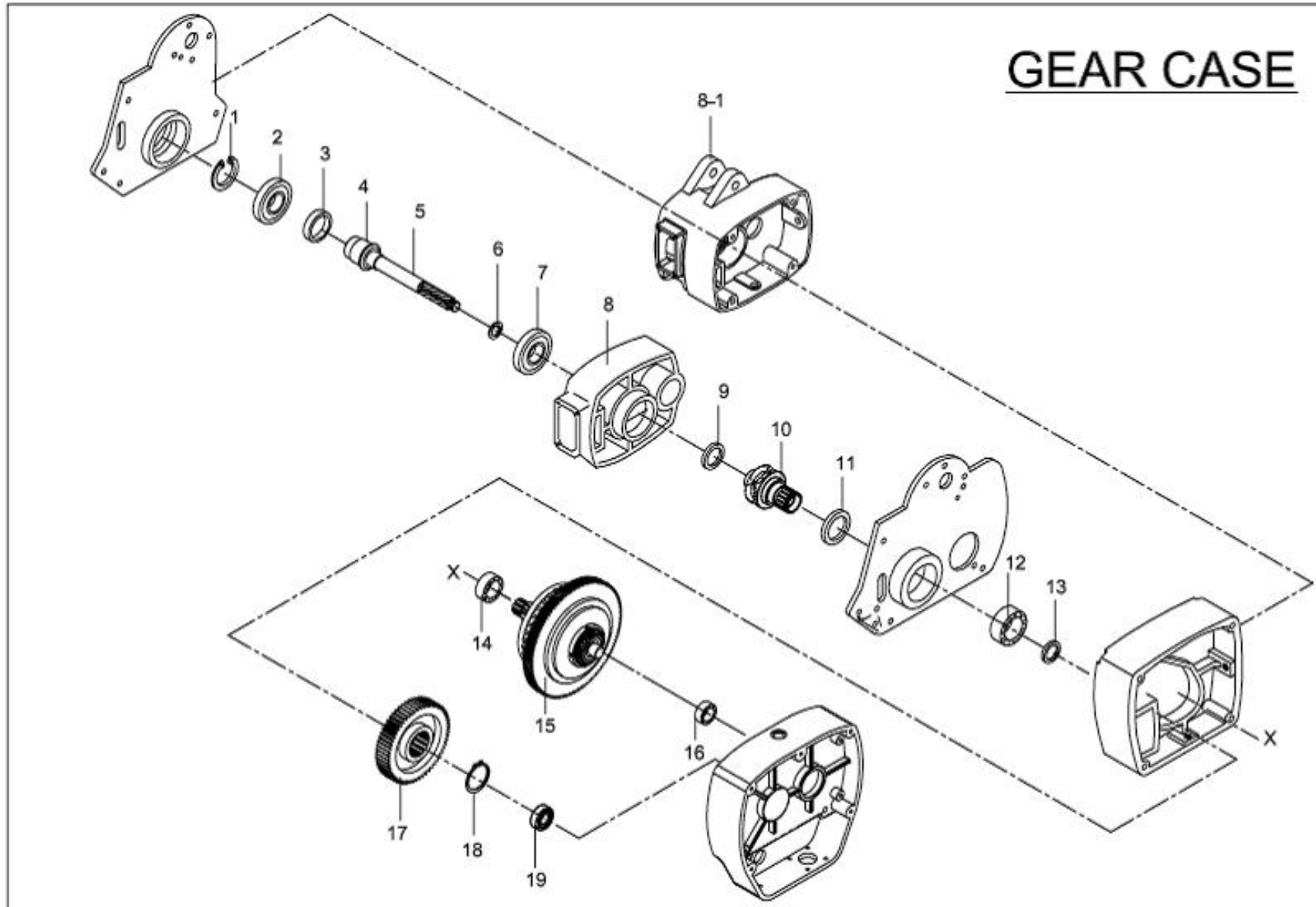

12.4 Parts List: Gear Case

Gear Case		Model Number ECH-															
#	Description	00518	00526	00544	01018	01026	01044	02018	02026	04009	04013	04026	06009	06017	10010	15007	20010
		Part Number															
1	Cir clip	166SKA										166SKB	166SKA	166SKB		166SKB x 2	
2	Ball bearing	167SKA										167SKB	167SKA	167SKB		167SKB x 2	
3	Spacer	502SKA										502SKB	502SKA	502SKB		502SKB x 2	
4	Connecting sleeve	168SKA										168SKB	168SKA	168SKB		168SKB x 2	
5	Secondary shaft	169SKA										169SKB	169SKA	169SKB		169SKB x 2	
6	O-ring	170SKA										170SKB	170SKA	170SKB		170SKB x 2	
7	Ball bearing	171SKA										171SKB	171SKA	171SKB		171SKB x 2	
8	Chain wheel case	-										138SKB	-	138SKB		138SKB x 2	
8-1	Chain wheel case	506SKA										-	506SKA	-		-	
9	Oil seal	172SKA										172SKB	172SKA	172SKB		172SKB x 2	
10	Load chain wheel	173SKA										173SKB	173SKA	173SKB		173SKB x 2	
11	Oil seal	174SKA										174SKB	174SKA	174SKB		174SKB x 2	
12	Ball bearing	175SKA										175SKB	175SKA	175SKB		175SKB x 2	
13	Oil seal	176SKA										176SKB	176SKA	176SKB		176SKB x 2	
14	Ball bearing	177SKA										177SKB	177SKA	177SKB		177SKB x 2	
15	Load brake & clutch Assembly	178SAH	178SAL	178SAH	178SAH	178SAL	178SAH	178SAL	178SAH	178SAL	178SAH	178SKB	178SAH	178SKB		178SKB x 2	
16	Ball bearing	501SKA										501SKB	501SKA	501SKB		501SKB x 2	
17	Main drive gear	186SAH	186SAL	186SAH	186SAH	186SAL	186SAH	186SAL	186SAH	186SAL	186SAH	168SKB	168SAH	168SKB		168SKB x 2	
18	Cir clip	187SKA										187SKB	187SKA	187SKB		187SKB x 2	
19	Ball bearing	188SKA										188SKB	188SKA	188SKB		188SKB x 2	

12.5 Exploded View: Chaining Parts

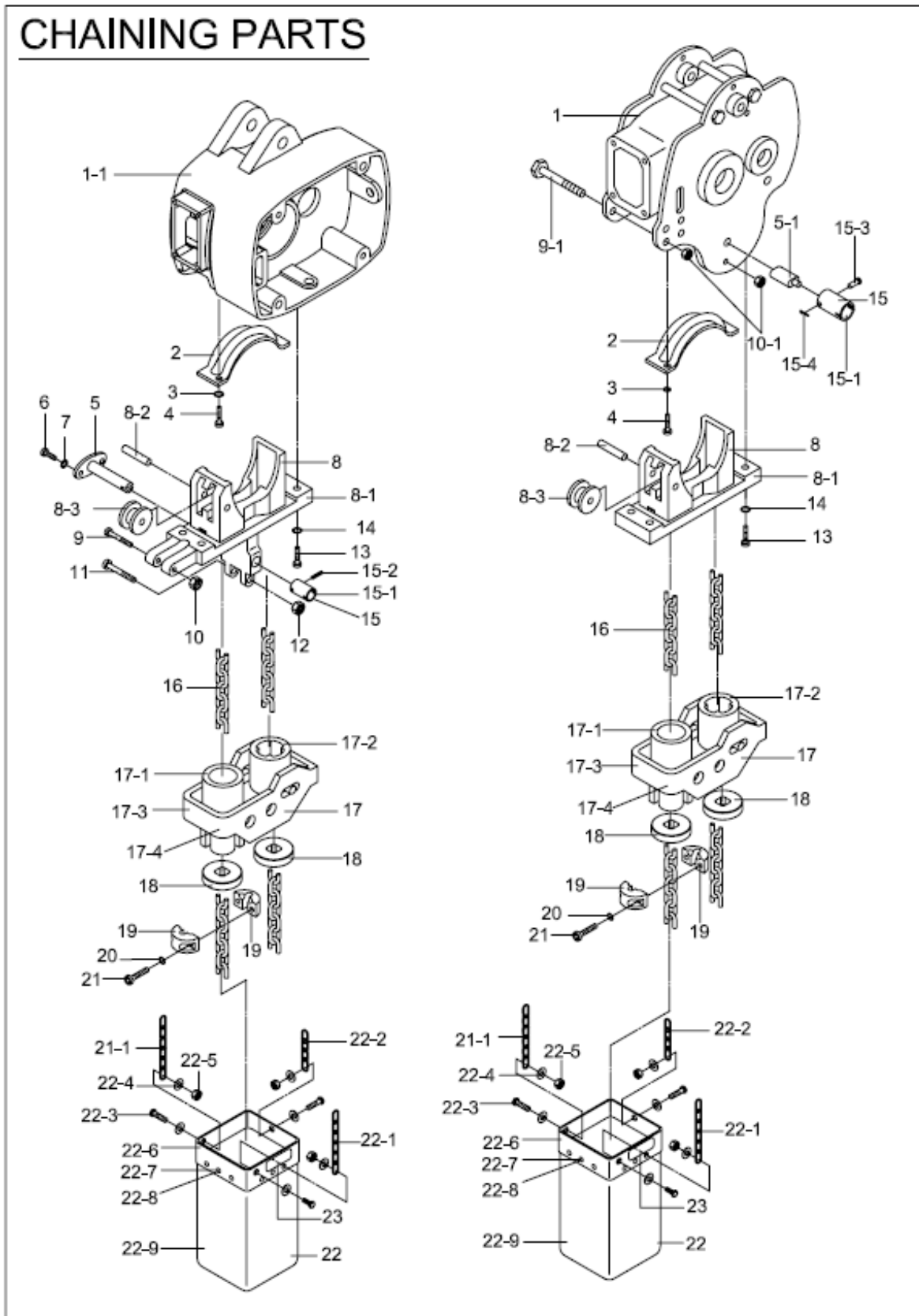

12.6 Parts List: Chaining Parts

Chaining Parts		Model Number ECH-															
#	Description	00518	00526	00544	01018	01026	01044	02018	02026	04009	04013	04026	06009	06017	10010	15007	20010
		Part Number															
1	Chain wheel case											138SKB	-	138SKB		138SKB x 2	
1-1	Chain wheel case	506SKA										-	506SKA			-	
2	Chain guide cover	189SKA										189SKB	189SKA	189SKB	189SKC	189SKC x 2	
3	Spring washer	237SKA x 2										237SKB x 2	237SKA x 2	237SKB x 2		237SKB x 4	
4	Cross slot round head bolt	190SKA x 2										190SKB x 2	190SKA x 2	190SKB x 2		190SKB x 4	
5	Limit switch actuator assembly B	191SKA										232SKB	191SKA	232SKB		232SKB x 2	
6	Hex socket cap bolt	194SKA x 2										-	194SKA x 2			-	
7	Spring washer	195SKA x 2										-	195SKA x 2			-	
8	Chain limit plate assembly	196SKA										196SKB	196SKA	196SKB	196SKC	196SKC x 2	
8-1	Chain limit plate	197SKA										197SKB	197SKA	197SKB	197SKC	197SKC x 2	
8-2	Guide wheel spindle	198SKA										198SKB	198SKA	198SKB	198SKC	198SKC x 2	
8-3	Guide wheel	199SKA										199SKB	199SKA	199SKB	199SKC	199SKC x 2	
9	Hex head bolt	200SKA										-	200SKA			-	
9-1	Hex head bolt	-										230SKB x 2	-	230SKB x 2		230SKB x 4	
10	Nylon nut	201SKA										-	201SKA			-	
10-1	Nylon nut	-										231SKB x 2	-	231SKB x 2		231SKB x 4	
11	Hex head bolt	202SKA										-	202SKA			-	
12	Nylon nut	203SKA										-	203SKA			-	
13	Hex socket cap bolt	204SKA x 4										204SKB x 2	204SKA x 2	204SKB x 4		204SKB x 8	
14	Spring washer	205SKA x 4										205SKB x 2	205SKA x 2	205SKB x 4		205SKB x 8	
15	Limit switch actuator assembly A (*)	206SKA										206SKB	206SKA	206SKB		206SKB x 2	
16	Chain	209SKA										209SKB	209SKA	209SKB		209SKC	
17	Chain guide assembly (*)	210SKA										210SKB	210SKA	210SKB	210SKC	210SKC x 2	
18	Rubber stopper	472SKA x 2										472SKB x 2	472SKA x 2	472SKB x 2	472SKC x 2	472SKC x 4	

Chaining Parts		Model Number ECH-																
#	Description	00518	00526	00544	01018	01026	01044	02018	02026	04009	04013	04026	06009	06017	10010	15007	20010	
		Part Number																
19	Chain end-stop block	216SKA x 2							216SKA x 4		216SKB x 2	216SKA x 2	216SKB x 4	216SKB x 2		216SKB x 4		
20	Spring washer	217SKA x 2							217SKA x 4		217SKB x 2	217SKA x 2	217SKB x 4	217SKB x 2		217SKB x 4		
21	Hex socket cap bolt	218SKA x 2							218SKA x 4		218SKB x 2	218SKA x 2	218SKB x 4	218SKB x 2		218SKB x 4		
22	Chain bag assembly (*)	219SKA															219SKA x 2	
23	Chain bag name plate	254SKA															254SKA x 2	

12.7 Exploded View: Hook Parts

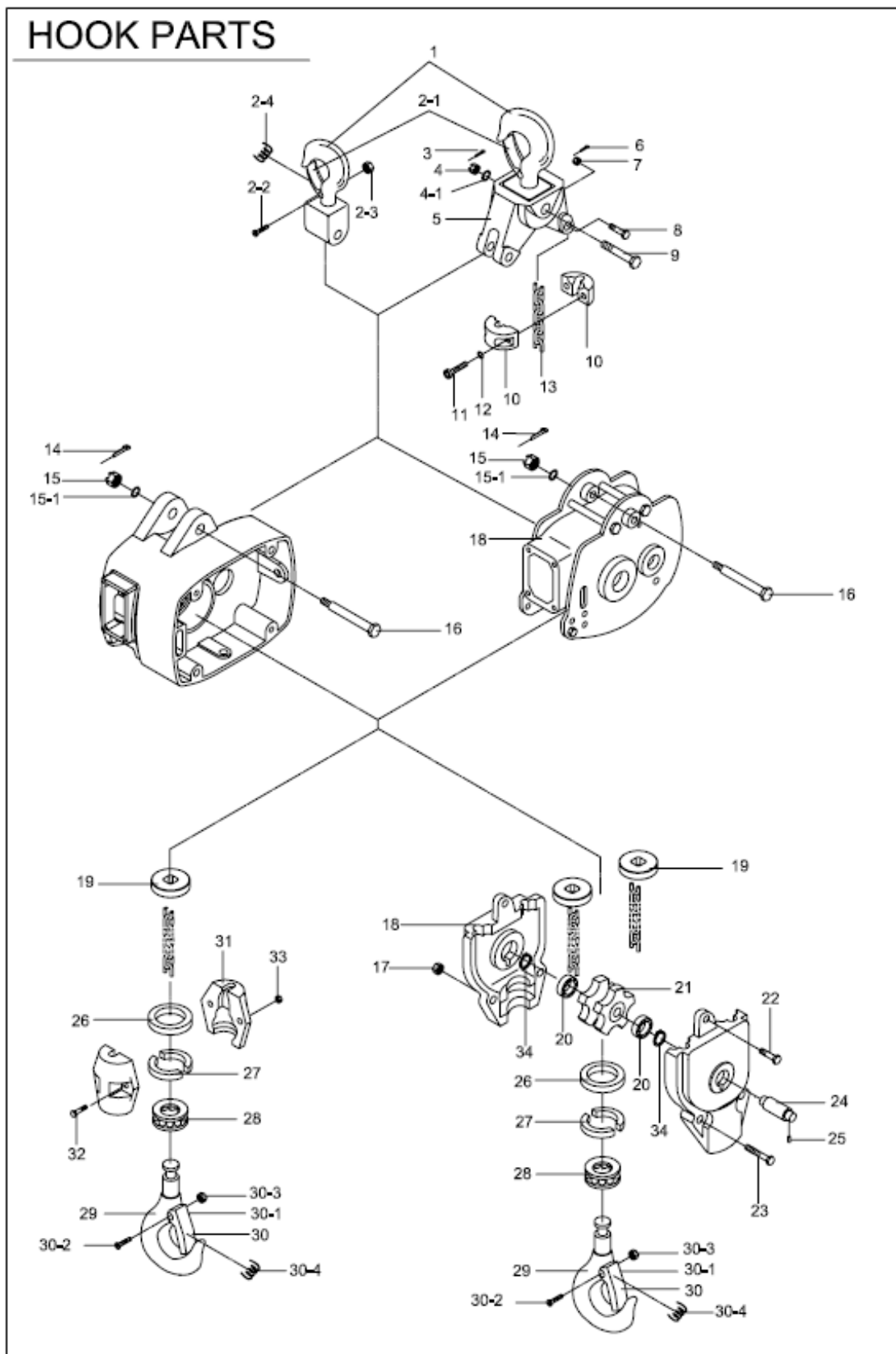

12.8 Parts List: Hook Parts

Hook Parts		Model Number ECH-													
#	Description	00518	00526	00544	01018	01026	01044	02018	02026	04009	04013	04026	06017	10010	
		Part Number													
1	Upper hook	270SKA						270SKB		270SKC		270SKD		270SKE	
2-1	Safety latch	272SKA						272SKB		272SKC		272SKD		272SKE	
2-2	Philip round head bolt	273SKA						273SKB		273SKC		273SKD		273SKE	
2-3	Nylon nut	274SKA						274SKB		274SKC		274SKD		274SKE	
2-4	Torsion spring	275SKA						275SKB		275SKC		275SKD		275SKE	
3	Split pin	276SKA						276SKB		276SKB					
4	Slotted nut	277SKA						277SKB							
4-1	Spring washer	475SKA						475SKB							
5	Upper hook yoke	278SKA						278SKB							
6	Split pin	279SKA						279SKB							
7	Slotted nut	480SKA						480SKB							
8	Upper hook yoke leg bolt	281SKA						281SKB							
9	Upper hook yoke cross bolt	282SKA						282SKB							
10	Chain end-stop block	216SKA x 2						216SKA x 4		216SKB x 2		216SKB x 4			
11	Hex socket cap bolt	218SKA x 2						218SKA x 4		218SKB x 2		218SKB x 4			
12	Spring washer	217SKA x 2						217SKA x 4		217SKB x 2		217SKB x 4			
13	Chain	209SKA						209SKB		209SKB		209SKC			
14	Split pin	287SKA						287SKB		287SKB					
15	Slotted nut	288SKA						288SKB		288SKB					
15-1	Spring washer	475SKA						475SKB		475SKB					
16	Upper hook cross bolt	289SKA						289SKB		289SKB					
17	Nylon nut	290SKA						290SKB		290SKB					
18	Lower hook block shell	291SKA x 2						291SKB x 2		291SKC x 2		291SKD x 2		291SKE x 2	
19	Rubber stopper	472SKA						472SKB x 2		472SKB x 2		472SKC x 2			
20	Needle bearing											293SKB		293SKC	
21	Lower hook block chain wheel											294SKB		294SKC	
22	Hex socket cap bolt											295SKB		295SKC	

Hook Parts		Model Number ECH-													
#	Description	00518	00526	00544	01018	01026	01044	02018	02026	04009	04013	04026	06017	10010	
		Part Number													
23	Hex socket cap bolt												296SKB	296SKC	
24	Lower hook block chain wheel spindle												297SKB x 2	297SKC x 2	
25	Spring pin												298SKB	298SKC	
26	Lower hook locking sleeve	299SKA											299SKB	299SKC	299SKD
27	Lower hook split ring	300SKA											300SKB	300SKC	300SKD
28	Thrust ball bearing	301SKA											301SKB	301SKC	301SKD
29	Lower hook	302SKA											302SKB	302SKC	302SKD
30	Safety latch assembly	303SKA											303SKB	303SKC	303SKD
30-1	Safety latch	304SKA											304SKB	304SKC	304SKD
30-2	Hex socket round head bolt	305SKA											305SKB	305SKC	305SKD
30-3	Nylon nut	306SKA											306SKB	306SKC	306SKD
30-4	Torsion spring	307SKA											307SKB	307SKC	307SKD
31	Lower hook block shell	291SKA x 2									291SKB*2	291SKC x 2	291SKD x 2	291SKE x 2	
32	Hex socket cap bolt	309SKA x 2													
33	Nylon nut	310SKA x 2													
34	Cir clip												505SKB x 2	505SKC x 2	

12.9 Exploded View: Hook Parts (3 Ton 3 Chain)

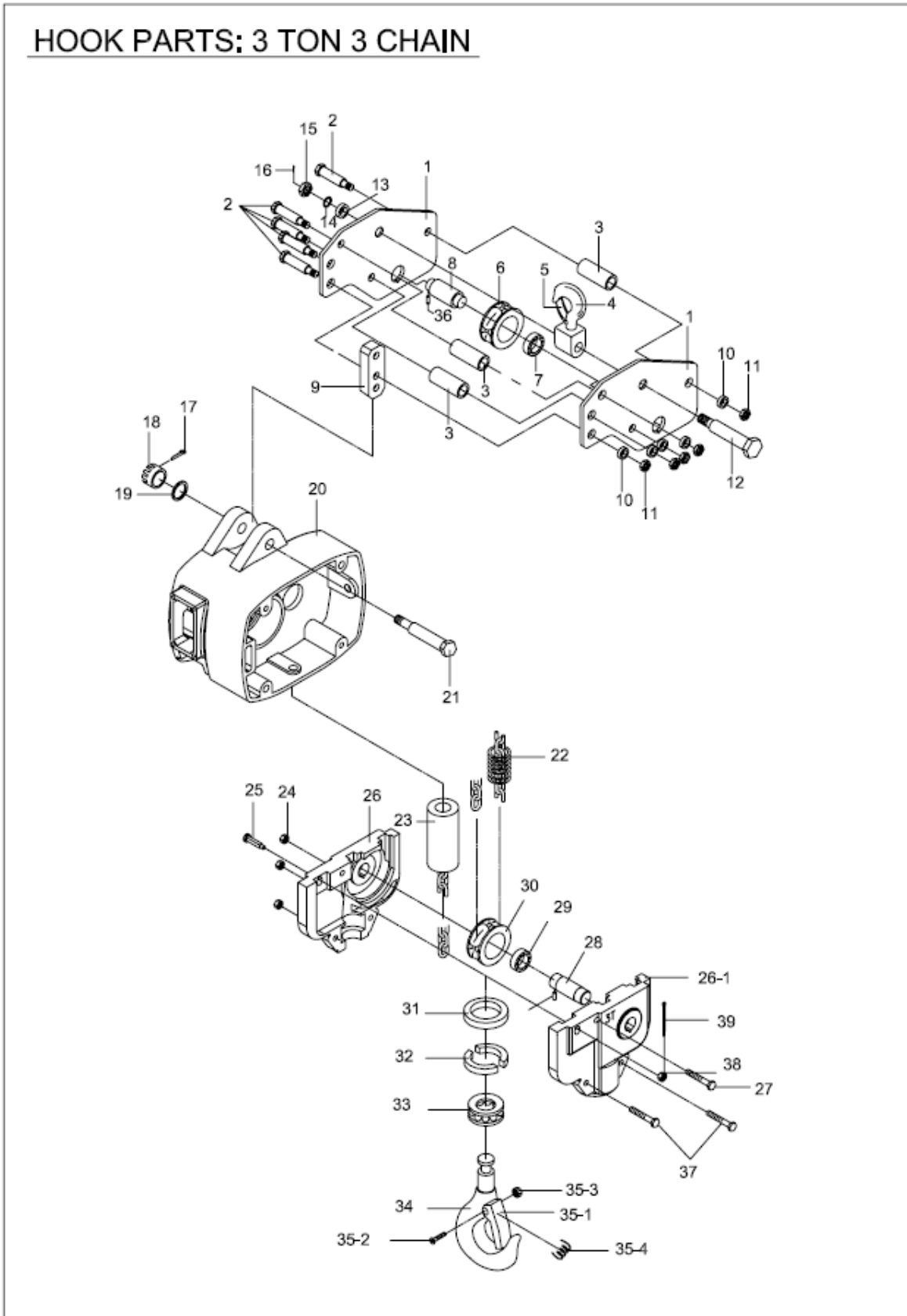

12.10 Parts List: Hook Parts (3 Ton 3 Chain)

Hook Parts 3 Ton 3 Chain		Model Number ECH-	
#	Description	06006	06009
		Part Number	
1	Upper hook block side plate	243SKA x 2	
2	Stay bolt	244SKA x 5	
3	Upper hook block spacer	245SKA x 3	
4	Upper hook	240SKA	
5	Safety latch	487SKA	
6	Upper hook block chain wheel	250SKA	
7	Needle bearing	477SKA	
8	Upper chain wheel spindle	251SKA	
9	Hook block attachment piece	246SKA	
10	Washer B	440SKA x 5	
11	Nylon nut	441SKA x 5	
12	Upper hook block cross bolt	478SKA	
13	Washer A	242SKA	
14	Spring washer	479SKA	
15	Slotted nut	480SKA	
16	Split pin	276SKA	
17	Split pin	287SKA	
18	Slotted nut	481SKA	
19	Spring washer	442SKA	
20	Chain wheel case	506SKA	
21	Upper hook cross bolt	289SKA	
22	Rubber stopper	472SKA x 3	

Hook Parts 3 Ton 3 Chain		Model Number ECH-	
#	Description	06006	06009
		Part Number	
23	Spacer tube	247SKA	
24	Nylon nut	482SKA x 3	
25	Lower hook block swivel shell side bolt	446SKA	
26	Lower hook block swivel shell (left)	248SKA	
26-1	Lower hook block swivel shell (right)	249SKA	
27	Hex socket cap bolt	444SKA	
28	Lower chain wheel spindle	251SKA	
29	Needle bearing	477SKA	
30	Lower hook block chain wheel	250SKA	
31	Lower hook locking sleeve	483SKA	
32	Lower hook split ring	484SKA x 2	
33	Thrust ball bearing	485SKA	
34	Lower hook	486SKA	
35	Safety latch assembly	487SKA	
35-1	Safety latch	488SKA	
35-2	Cross slot round head bolt	489SKA	
35-3	Nylon nut	490SKA	
35-4	Torsion spring	491SKA	
36	Spring pin	492SKA x 2	
37	Hex socket cap bolt	445SKA x 2	
38	Slotted nut	480SKA	

12.11 Exploded View: Load Block - 7½ Ton

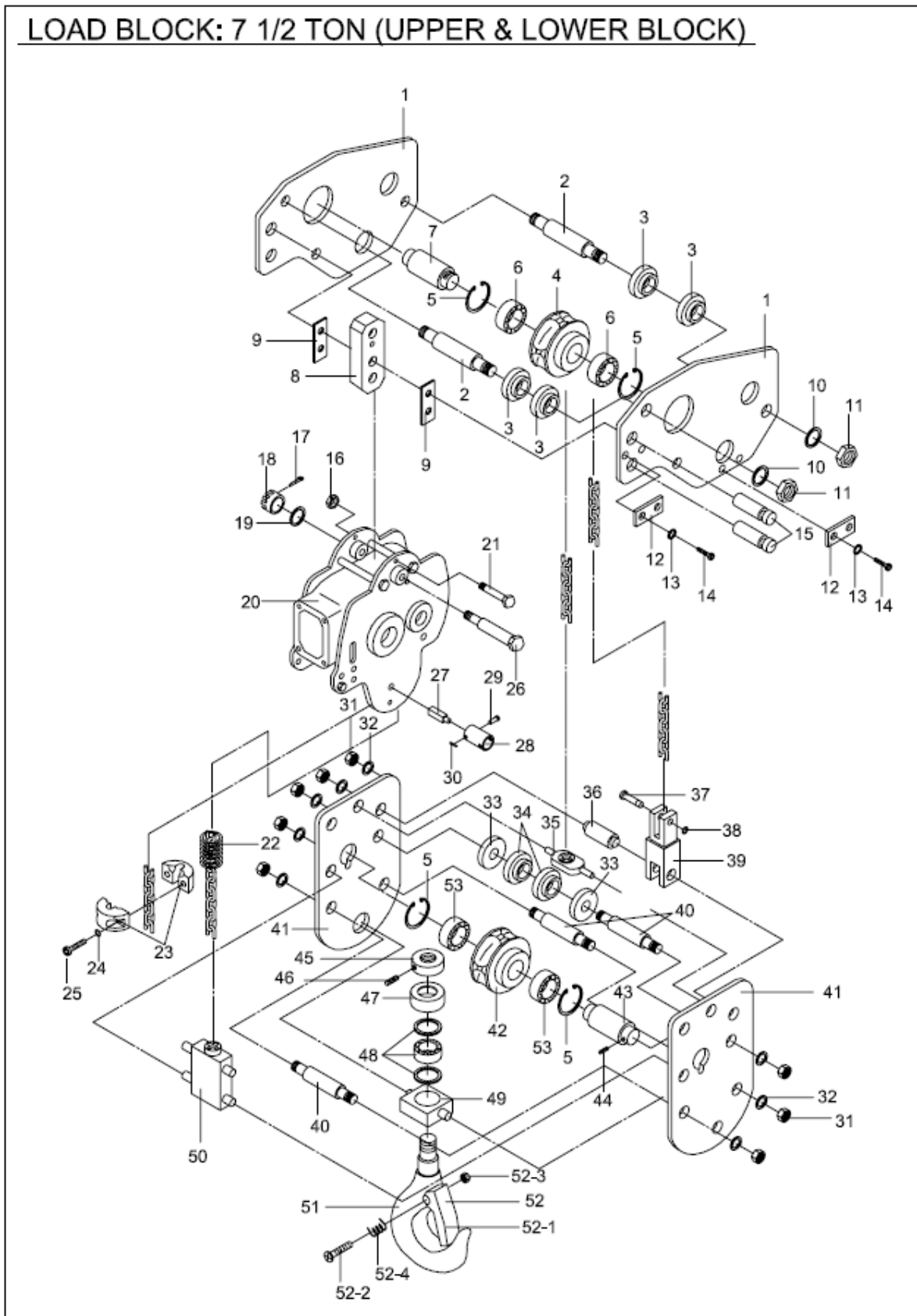

12.12 Parts List: Load Block - 7½ Ton

7 1/2 Ton U/L Hook Block Parts		Model ECH-15007
#	Description	Part Number
1	Upper load block side plate	311SKB x 2
2	Stay bolt	312SKB x 3
3	Flanged guide wheel	313SKB x 4
4	Upper load block chain wheel	314SKB
5	C-retaining ring	315SKB x 4
6	Needle bearing	316SKB x 2
7	Upper chain wheel spindle	317SKB
8	Load block attachment piece	318SKB
9	Attachment piece spacer	319SKB x 2
10	Spring washer	320SKB x 6
11	Nut	321SKB x 6
12	Lock plate	322SKB x 2
13	Spring washer	323SKB x 4
14	Hex socket cap bolt	324SKB x 4
15	Attachment piece cross pin	325SKB x 2
16	Nylon nut	326SKB
17	Split pin	327SKB
18	Slotted nut	328SKB
19	Spring washer	329SKB
20	Chain wheel case	138SKB
21	Hex head bolt	330SKB
22	Rubber stopper	472SKB x 2
23	Chain end-stop block	332SKB x 2
24	Spring washer	333SKB x 2
25	Hex socket cap bolt	334SKB x 2
26	Upper load block cross bolt	289SKB
27	Limit switch actuator B	232SKB
28	Limit switch actuator A	207SKB
29	Hex socket cap bolt	234SKB

7 1/2 Ton U/L Hook Block Parts		Model ECH-15007
#	Description	Part Number
30	Nylon nut	235SKB
31	Nut	335SKB x 6
32	Spring washer	336SKB x 6
33	Guide wheel thrust washer	337SKB x 4
34	Flanged guide wheel	338SKB x 4
35	Chain guide piece	339SKB
36	Clevis pin	340SKB
37	Chain attachment pin	341SKB
38	Cir clip	342SKB
39	Chain attachment clevis	343SKB
40	Side plate stay bolt	344SKB x 3
41	Lower hook block side plate	345SKB x 2
42	Lower hook block chain wheel	346SKB
43	Lower chain wheel spindle	347SKB
44	Spring pin	348SKB
45	Lower hook retaining nut	349SKB
46	Set screw	350SKB
47	Bearing cover	351SKB
48	Thrust ball bearing	352SKB
49	Lower hook mounting block	353SKB
50	Chain guide block	354SKB
51	Lower hook	355SKB
52	Safety latch assembly	356SKB
52-1	Safety latch	357SKB
52-2	Cross slot round head bolt	358SKB
52-3	Nylon nut	359SKB
52-4	Torsion spring	360SKB
53	Needle bearing	447SKB x 2

12.13 Exploded View: Load Block - 10 Ton

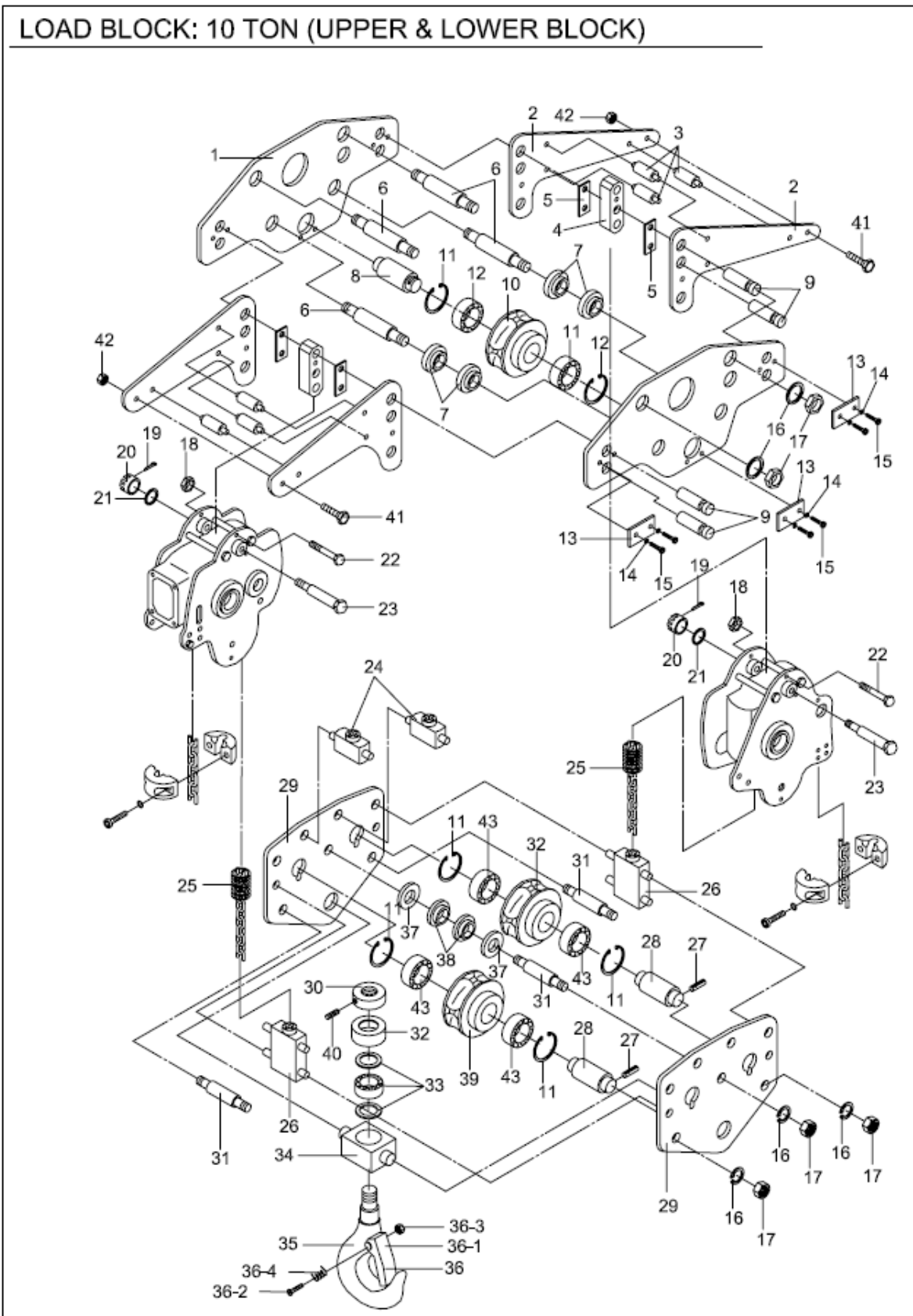

12.14 Parts List: Load Block - 10 Ton

10 Ton U/L Hook Block Parts		Model ECH-
#	Description	20010
		Part Number
1	Upper load block side plate	361SKB x 2
2	Chain bag hanger arm	362SKB x 4
3	Hanger arm stay pin	363SKB x 6
4	Upper block attachment piece	318SKB x 2
5	Attachment piece spacer	319SKB x 4
6	Slide plate stay bolt	312SKB x 4
7	Flanged guide wheel	313SKB x 4
8	Upper chain wheel spindle	317SKB
9	Attachment piece cross pin	325SKB x 4
10	Upper load block chain wheel	314SKB
11	Cir Clip	315SKB x 6
12	Needle Bearing	316SKB x 2
13	Lock Plate	322SKB x 3
14	Spring washer	323SKB x 6
15	Hex socket cap bolt	324SKB x 6
16	Spring washer	320SKB x 14
17	Nut	321SKB x 14
18	Nylon nut	326SKB x 2
19	Split pin	327SKB x 2
20	Slotted nut	328SKB x 2
21	Spring washer	329SKB x 2
22	Hex socket cap bolt	330SKB x 2
23	Upper load block cross bolt	289SKB x 2

10 Ton U/L Hook Block Parts		Model ECH-
#	Description	20010
		Part Number
24	Chain guide piece	339SKB x 2
25	Robber stopper	472SKB x 4
26	Chain guide block	354SKB x 2
27	Spring pin	348SKB x 2
28	Lower chain wheel spindle	347SKB x 2
29	Lower hook block side plate	347SKB x 2
30	Lower hook retaining nut	365SKB
31	Side plate stay bolt	344SKB x 3
32	Bearing cover	351SKB
33	Thrust ball bearing	352SKB
34	Lower hook mounting block	353SKB
35	Lower hook	366SKB
36-1	Safety latch	368SKB
36-2	Cross slot round head bolt	369SKB
36-3	Nylon nut	370SKB
36-4	Torsion spring	371SKB
37	Guide wheel thrust washer	337SKB x 6
38	Flanged guide wheel	338SKB x 6
39	Lower hook block chain wheel	346SKB x 2
40	Set screw	350SKB
41	Hex head bolt	513SKB x 2
42	Nylon nut	231SKB x 2
43	Needle bearing	447SKB x 4

12.15 Exploded View: Electrical System

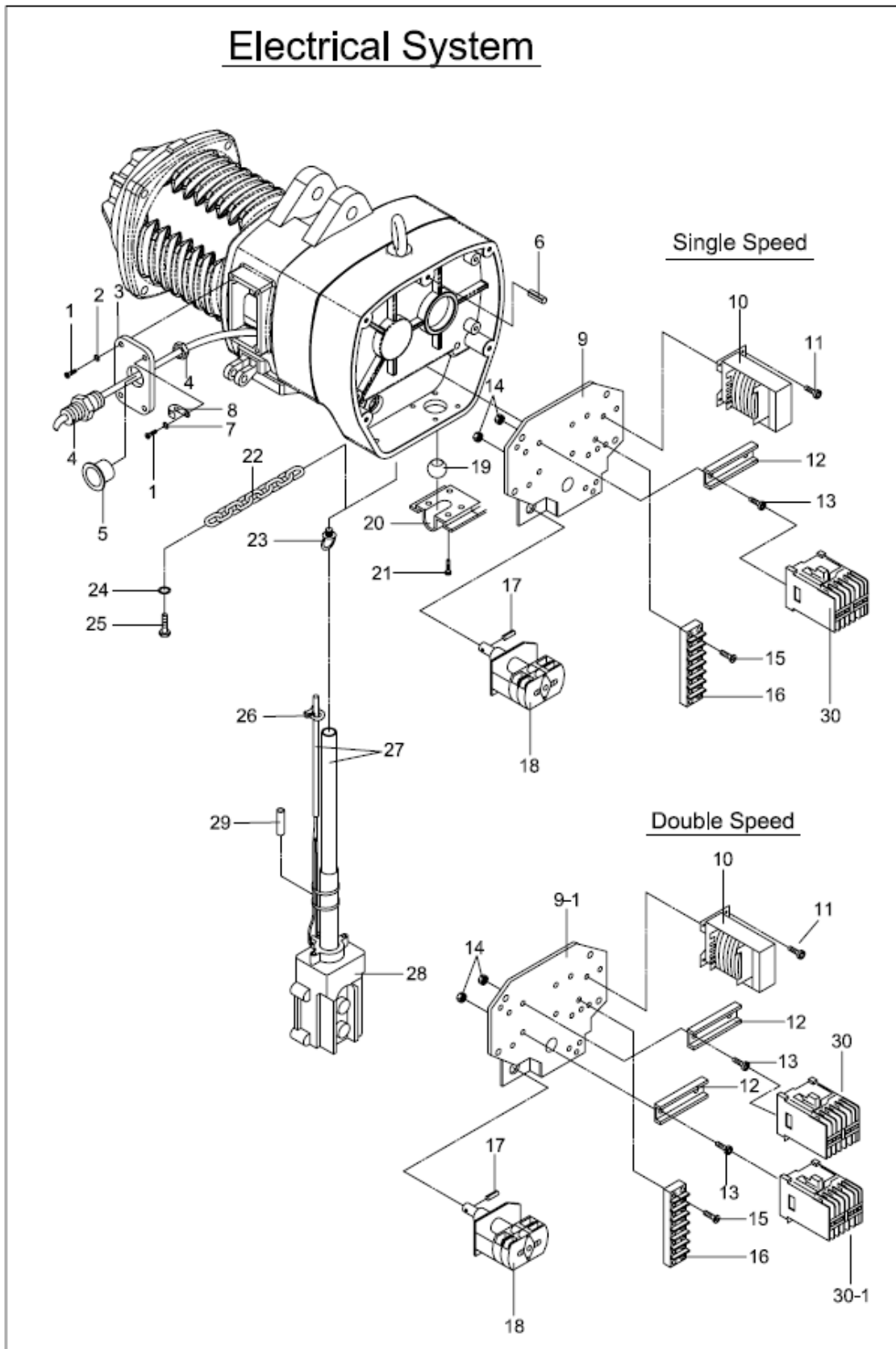

12.16 Parts List: Electrical System

Electrical System		Model Number															
#	Description	00518	00526	00544	01018	01026	01044	02018	02026	04009	04013	04026	06009	06017	10010	15007	20010
		Part Number															
1	Philip round head bolt	372SKA x 4															372SKA x 8
2	Spring washer	373SKA x 4															373SKA x 8
3	Power cable inlet cover	374SKA															374SKA x 2
4	Cable gland	375SKA															375SKA x 2
5	Hole plug	376SKA															376SKA x 2
6	Spring pin	377SKA															377SKA x 2
7	Plain washer	378SKA															378SKA x 2
8	Cable clamp	379SKA															379SKA x 2
9	Mounting panel	380SKA											380SKB	380SKA	380SKB	380SKB x 2	
10	Transformer	381SKA															381SKA x 2
11	Philip round head bolt	382SKA x 4															382SKA x 8
12	Mounting rail	383SKA															383SKA x 2
13	Philip pan head bolt	384SKA x 2															384SKA x 4
14	Nylon nut	385SKA x 2															385SKA x 4
15	Philip round head bolt	386SKA x 2															386SKA x 4
16	Terminal block	387SKA															387SKA x 2
17	Spring pin	392SKA															392SKA x 2
18	Limit switch	393SKA															393SKA x 2
19	PG32 Cable gland nut	394SKA															394SKA x 2
20	Cable gland rubble washer	395SKA															395SKA x 2
21	PG32 Cable gland body	372SKA															372SKA x 2
22	Connecting chain	396SKA															396SKA x 2
23	Hex socket cap bolt	399SKA															399SKA x 2
24	Plain washer	398SKA x 2															398SKA x 4
25	Hex socket cap bolt	399SKA															399SK x 2
26	Pendant control support wire clamp	400SKA															400SK
27	Electric cable and support wire	401SKA															401SK
28	Pendant control unit	402SKA															402SK
29	Sleeve	403SKA															403SK
30	Relay block	404SKA x 2															404SK x 4
30-1	Relay block	D404SKA x 3															404SK x 6

12.17 Exploded View: Motorized Trolley - 1/4 to 5 Ton

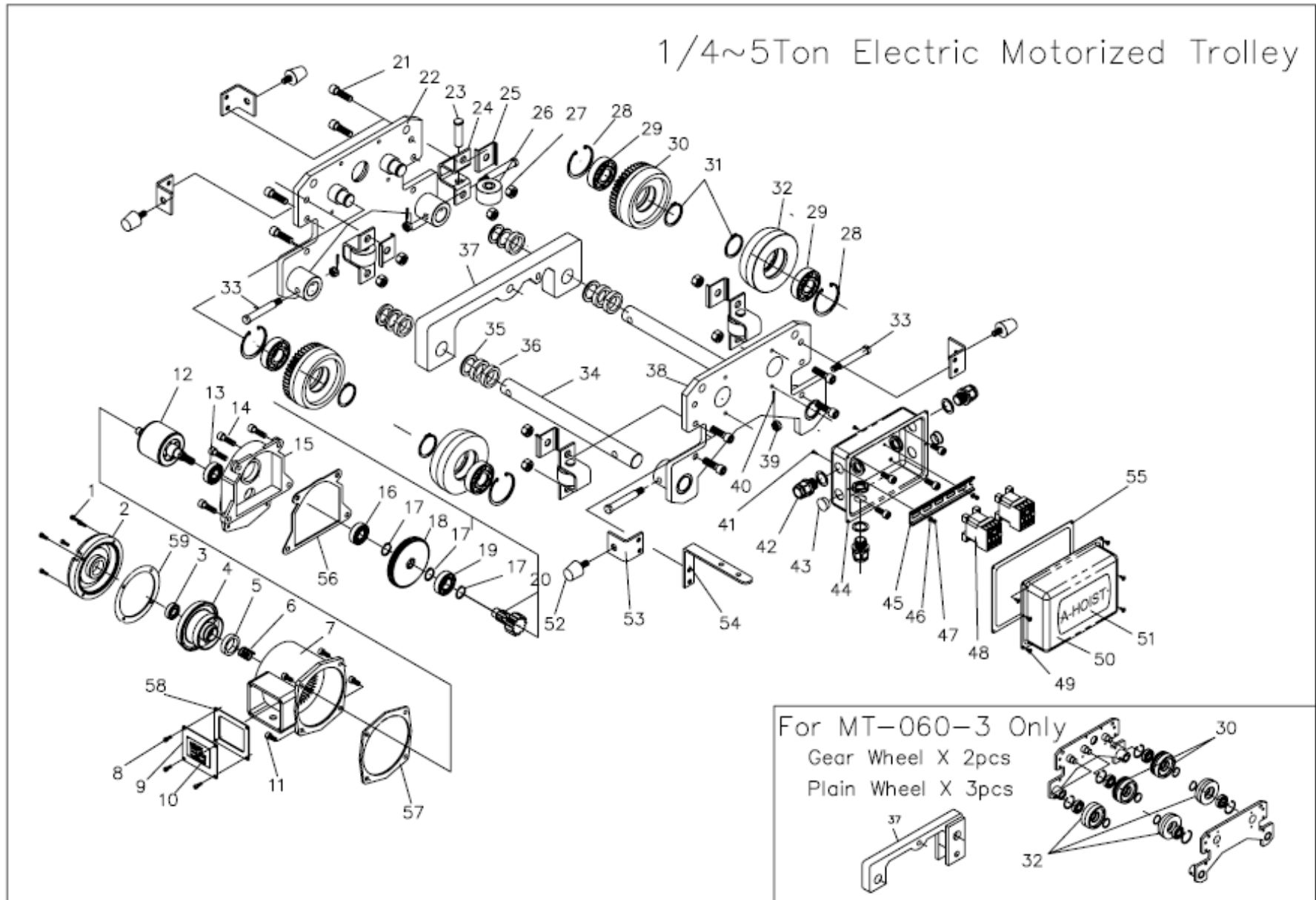

12.18 Parts List: Motorized Trolley - 1/4 to 5 Ton

Motorized Trolley		Model								
#	Description	MT-005	MT-010	MT-020	MT-040-1	MT-040-2	MT-060-2	MT-060-3	MT-100	
1	Hex Socket Cap Bolt				ECH-T107A					
2	Brake Cover				ECH-T106A					
3	Ball Bearing				ECH-T105A					
4	Brake Disk Assembly				ECH-T104A					
5	Rubber Collar				ECH-T103A					
6	Brake Spring				ECH-T102A					
7	Motor Casing & Stator				ECH-T101A					
8	Hex Socket Cap Bolt				ECH-T109A x 4					
9	Power Cable Inlet Cover				ECH-T108A					
10	Motor Name Plate				ECH-T171A					
11	Hex Socket Cap Bolt				ECH-T110A x 4					
12	Motor Rotor & Primary Shaft		ECH-T111A				ECH-T111B			
13	Ball Bearing				ECH-T113A					
14	Hex Socket Cap Bolt				ECH-T112A x 4					
15	Gear Reducer Case				ECH-T114A					
16	Ball Bearing				ECH-T115A					
17	C Retaining Ring				ECH-T116A x 3					
18	Driving Gear				ECH-T117A					
19	Ball Bearing				ECH-T119B				ECH-T118B	
20	Pinion				ECH-T119A				ECH-T119B	
21	Hex Socket Cap Bolt				ECH-T128A x 8				ECH-T128B x 8	
22	Side Plate A		ECH-T159A			ECH-T159B			ECH-T159C	
23	Guide Wheel Shaft*				ECH-T135A x 4				ECH-T135B x 4	
24	Guide Wheel Seat*				ECH-T136A x 4				ECH-T136B x 4	
25	Guide Wheel Press Plate*				ECH-T133A X 4				ECH-T133B x 4	
26	Guide Wheel*				ECH-T137A x 4				ECH-T137B x 4	
26-1	Guide Wheel Assembly (includes *)				ECH-T137AA				ECH-T137BA	
27	Hex Nut				ECH-T134A x 8				ECH-T134B x 8	
28	C Retaining Ring			ECH-T120A x 4			ECH-T121B x 4			
29	Ball Bearing			ECH-T121A x 4			ECH-T121B x 4			
30	Gear Wheel			ECH-T125A x 2			ECH-T125B x 2			
31	C Retaining Ring			ECH-T123A x 4			ECH-T123B x 4			
32	Plain Wheel			ECH-T122A x 2			ECH-T122B x 2			
33	Position Bolt			ECH-T126A x 2						
34	Suspension Shaft			ECH-T158A x 2			ECH-T158B x 2			
35	Thing Spacer			ECH-T148A x 16			ECH-T148B 16			
36	Thick Spacer			ECH-T149A x 16			ECH-T149B x 16			

Electric Chain Hoists (Dual Brake)

Model ECH

ECH-0214

689 SW 7th Terrace, Dania Beach, FL 33004 | (954) 367-6116

PAGE: 98

Visit WWW.ACIHOIST.COM for the most current information

Motorized Trolley 1/4 to 5 Ton		Model							
#	Description	MT-005	MT-010	MT-020	MT-040-1	MT-040-2	MT-060-2	MT-060-3	MT-100
37	Support Yoke				ECH-T161A				
38	Side Plate B				ECH-T160A				
39	Castle Nut				ECH-T130A x 2				
40	Cotter Pin				ECH-T139A x 2				
41	Phil Round Head Screw				ECH-T140A x 4				
42	Cable Gland				ECH-T143A x 3				
43	Plastic Cap				ECH-T145A x 3				
44	Electric Case				ECH-T144A				
45	Rail				ECH-T153A				
46	Washer				ECH-T154A x 2				
47	Hex Socket Cap Bolt				ECH-T132A x 2				
48	Magnetic Contactor				ECH-T156A x 2				
49	Hex Socket Cap Bolt				ECH-T152A x 4				
50	Electric Case Cover				ECH-T146A				
51	Trolley Name Plate	ECH-T127A	ECH-T127B	ECH-T127C	ECH-T127D	ECH-T127E	ECH-T127F	ECH-T127G	ECH-T127I
52	Rubber Bumper				ECH-T172A x 4				
53	Anti-Drop Fin				ECH-T173A x 4				
54	Cable Arm				ECH-T174				
55	Gasket MT-01				ECH-T175				
56	Gasket MT-02				ECH-T176				
57	Gasket MT-03				ECH-T177				
58	Gasket MT-04				ECH-T178				
59	Gasket				ECH-T179				

Electric Chain Hoists (Dual Brake)

Model ECH

ECH-0214

689 SW 7th Terrace, Dania Beach, FL 33004 | (954) 367-6116

12.19 Exploded View: Motorized Trolley - 7.5 to 10 Ton

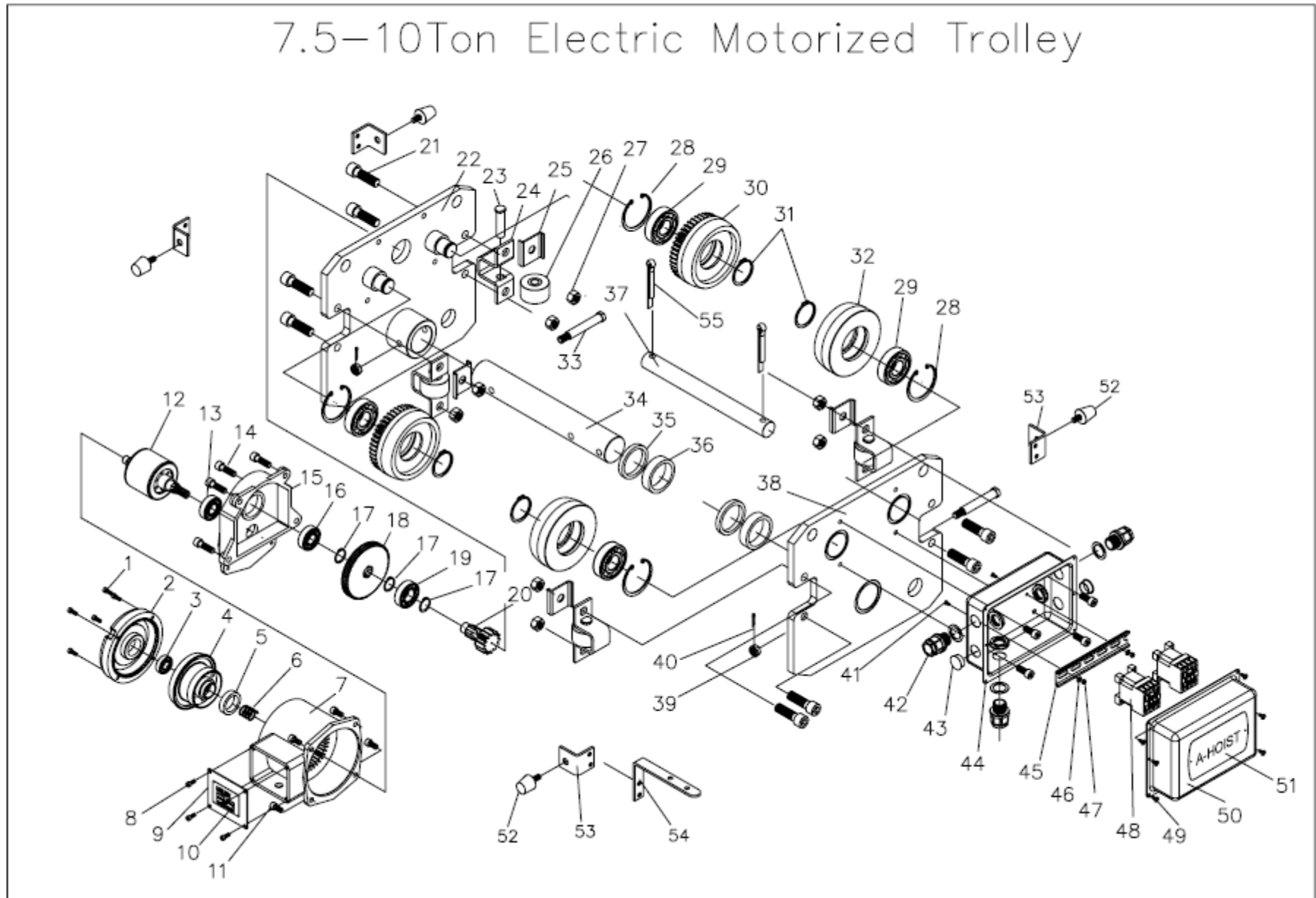

Electric Chain Hoists (Dual Brake)

Model ECH

ECH-0214

689 SW 7th Terrace, Dania Beach, FL 33004 | (954) 367-6116

PAGE: 100

Visit WWW.ACIHOIST.COM for the most current information

12.20 Parts List: Motorized Trolley - 7.5 to 10 Ton

Motorized Trolley 7.5 to 10 Ton		Model	
#	Description	MT-150	MT-200
1	Hex Socket Cap Bolt		ECH-T107A
2	Brake Cover		ECH-T106A
3	Ball Bearing		ECH-T105A
4	Brake Disk Assembly		ECH-T104A
5	Rubber Collar		ECH-T103A
6	Brake Spring		ECH-T102A
7	Motor Casing and Stator		ECH-T101A
8	Hex Socket Cap Bolt		ECH-T109A x 4
9	Power Cable Inlet Cover		ECH-T108A
10	Motor Name Plate		ECH-T171A
11	Hex Socket Cap Bolt		ECH-T110A x 4
12	Motor & Primary Shaft		ECH-T111B
13	Ball Bearing		ECH-T113A
14	Hex Socket Cap Bolt		ECH-T112A x 4
15	Gear Reducer Case		ECH-T114A
16	Ball Bearing		ECH-T115A
17	C Retaining Ring		ECH-T116A x 3
18	Driving Gear		ECH-T117A
19	Ball Bearing		ECH-T118B
20	Pinion		ECH-T119B
21	Hex Socket Cap Bolt		ECH-T128B x 8
22	Side Plate A	ECH-T159D	ECH-T159E
23	Guide Wheel Shaft*		ECH-T135B x 4
24	Guide Wheel Seat*		ECH-T136B x 4
25	Guide Wheel Press Plate*		ECH-T133B x 4
26	Guide Wheel*		ECH-T137B x 4
26-1	Guide Wheel Assembly (includes *)		ECH-T137BA
27	Hex Nut		ECH-T134B x 8
28	C Retaining Ring	ECH-T120C x 4	ECH-T120D x 4
29	Ball Bearing	ECH-T121C x 2	ECH-T121D x 2
30	Gear Wheel	ECH-T125C x 4	ECH-T125D x 4
31	C Retaining Ring	ECH-T123C x 4	ECH-T123D x 4
32	Plain Wheel	ECH-T122C x 2	ECH-T122D x 2
33	Position Bolt		ECH-T126B x 2
34	Suspension Shaft-A		ECH-T158C
35	Thin Spacer		ECH-T148C x 16
36	Thick Spacer		ECH-T149C x 16
37	Suspension Shaft-B		ECH-T158D
38	Side Plate B	T160D	T160E

Motorized Trolley 7.5 to 10 Ton		Model	
#	Description	MT-150	MT-200
39	Castle Nut		ECH-T130B x 2
40	Cotter Pin		ECH-T139B x 2
41	Phil Round Head Screw		ECH-T140A x 4
42	Cable Gland		ECH-T143A x 3
43	Plastic Cap		ECH-T145A x 3
44	Electric Case		ECH-T144A
45	Rail		ECH-T153A
46	Washer		ECH-T154A x 2
47	Hex Socket Cap Bolt		ECH-T132A x 2
48	Magnetic Contactor		ECH-T156A x 2
49	Hex Socket Cap Bolt		ECH-T152A x 4
50	Electric Case Cover		ECH-T146A
51	Trolley Name Plate	ECH-T127H	ECH-T127J
52	Rubber Bumper		ECH-T172A x 4
53	Anti-Drop Fin		ECH-T173A x 4
54	Cable Arm		ECH-T174A
55	Cotter Pin		ECH-T175A x 2