

## 'S' Series Chain Block Close Coupled to Geared Girder Trolley

Capacities: 1 to 5 Tons

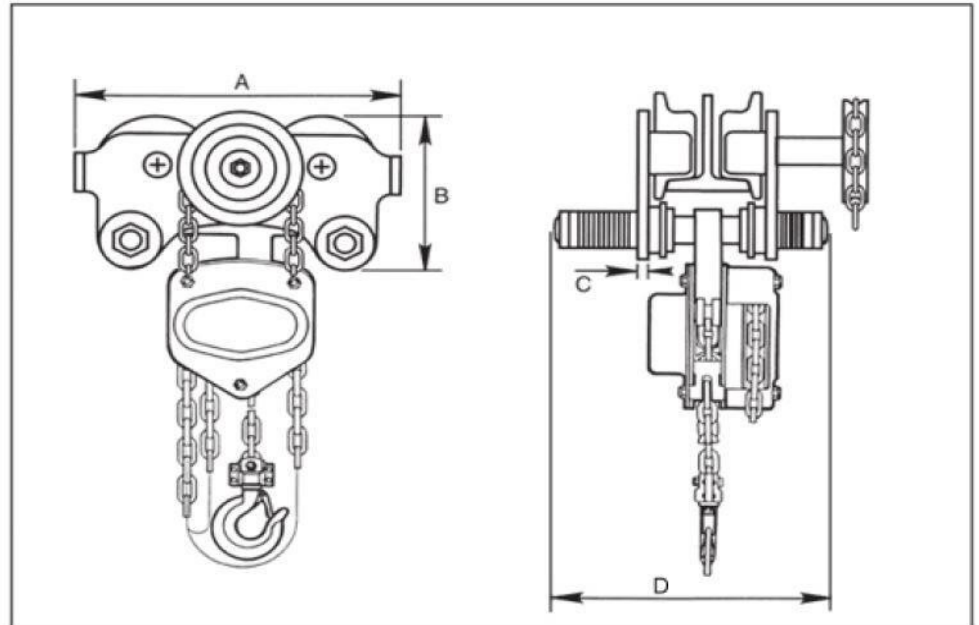

- Integrated Hoist & Trolley (for minimal headroom & theft protection)
- Ergonomic Design (Minimal Effort to Lift Loads)
- Super Strength Alloy Chain
- Durable Baked Enamel Paint Protection
- Cast Steel Safety Latches
- Robust All Steel Construction
- Weather Protected Weston Brake
- Stainless Steel Name Plates
- Overload Protection Available (Optional Add-On)
- Spare Parts in Stock



# ARMY TYPE TROLLEY HAND CHAIN HOIST



Capacity (Ton)	Model Number	Test Load** (125%) Lbf	Min Radius (ft)	Pilling Force to Lift Full Load (***)Lbf	Standard Lift (Ft)	Dimensions (in)				Beam Width (in)	Min Headroom (in)
						A	B	C	D		
1/2	HCHLH*-010-10	1,250	3.3	9	10	10.9	6.7	0.4	11.1	3.0-7.0	14.8
1	HCHLH*-020-10	2,500	3.3	9	10	10.9	6.7	0.4	11.1	3.0-7.0	14.8
2	HCHLH*--040-10	5,000	3.9	16	10	11.9	7.6	0.5	11.6	3.0-7.0	17.2
3	HCHLH*-060-10	3,750	4.6	15	10	14.3	9.1	0.6	12.0	3.0-7.0	23.3
5	HCHLH*-100-10	12,500	5.2	22	10	17.2	10.2	0.7	13.0	4.0-7.0	29.2

\* Add G=Geared, P=Pushed

\*\*Lbf pound force

\*\*\*Load Test at 125%

Capacity (Ton)	Model Number	Standard Lift (ft)	Hand Chain Drop (ft)	Min Radius of Curve (ft)	No. of Chain Falls	Weight per Unit (lbs)
1/2	HCHLH*-010-10	10	8	3.3	1	53
1	HCHLH*-020-10				1	53
2	HCHLH*--040-10				1	86
3	HCHLH*-060-10				2	123
5	HCHLH*-100-10				2	191

\* Add G=Geared, P=Pushed