

OPERATION MANUAL

This operation manual is intended as an instruction manual for trained personnel who oversee installation, maintenance, repair etc.



Before equipment use, please read this operation manual

Serial Number: _____

Date Purchased: _____



TABLE OF CONTENTS

1.0 WARRANTY	5
2.0 SAFETY PRECAUTIONS	6
2.1 Safety Alert Symbols	6
2.2 Important Information and Warnings	7
2.3 Safe Hoisting and OSHA Compliance	8
2.4 Warning Tags and Labels	10
2.5 General Safe Operation Requirements	11
3.0 GENERAL DESCRIPTION & FEATURES	12
3.1 Model Numbering	12
3.2 Pendant Control	13
4.0 INSTALLATION	15
4.1 Prior to Installing Hoist	15
4.2 Installation of Hoist	16
4.2.1 Installation of Hoist with Trolley	17
4.2.2 Installation of Trolley Hoist on the Beam	20
4.2.3 Connecting Power Supply to Hoist	21
4.2.4 Load Chain	21
4.3 Prior To Operation	23
4.3.1 Motor Phasing	23
4.3.1 Trolley Motor Phasing	24
4.4 Testing Limit Switches	24
4.5 Hoist Load Test	25
5.0 OPERATION	26
5.1 General Safety	26
5.1.1 General DO's and DO NOT'S	27
5.2 Safety Rules before Operating the Hoist	27
5.3 Safety Rules for Operating the Hoist	28
5.4 Safety Rules for Parking the Load	28
5.5 Safety Rules before Each Shift	29
6.0 INSPECTION	30
6.1 Prior to Maintenance or Inspection	30
6.1.1 Inspection Records	31
6.2 Inspection Classification	31
6.3 Daily, Frequent & Periodic Inspections	32
6.4 Hook Inspection	34
6.5 Limit Switch Inspection	36
6.6 Load Chain Inspection	39
6.7 Hoist Motor Brake Inspection	41

6.8 Trolley Inspection.....	42
6.9 Tests.....	44
6.9.1 Operational Test.....	44
6.9.2 Load Test.....	46
7.0 MAINTENANCE & REPAIR.....	47
7.1 Lubrication.....	47
7.1.1 Hoist Gear Housing.....	47
7.1.2 Hook Thrust Bearing.....	48
7.1.3 Chain Lubrication.....	48
7.2 Chain Maintenance.....	49
7.3 Chain Replacement.....	49
7.4 Hoist Motor Brake Adjustment.....	51
7.5 Hoist Motor Brake Disassembly.....	53
8.0 TROUBLESHOOTING.....	55
9.0 WIRING DIAGRAMS.....	57
10.0 DIMENSIONS & SPECIFICATIONS.....	58
10.1 Table of Specifications.....	58
10.2 Hoist Specifications.....	59
10.3 Hoist Dimensions.....	59
11.0 EXPLODED VIEWS & PARTS LISTS.....	62
11.1 Exploded View: Motor & Body Assembly.....	62
11.2 Parts List: Motor and Body Assembly.....	63
11.3 Exploded View: Chain Assembly.....	65
11.4 Parts List: Chain Assembly.....	66
11.5 Exploded View: Hook Assembly.....	67
11.6 Parts List: Hook Assembly.....	68
11.7 Exploded View: Gear Box Assembly.....	70
11.8 Parts List: Gear Box Assembly.....	71

1.0 WARRANTY

Every product is thoroughly inspected and tested before it is shipped from the factory. If any problem develops within one year, return the product prepaid to the factory. If an inspection reveals that the problem is caused by defective workmanship or material, repairs will be made without charge and the product will be returned with the shipping prepaid.

Excluded Items

This warranty does not cover:

- Deterioration caused by normal wear, abuse, chemical or abrasive actions, improper maintenance or excessive heat.
- Problems resulting from repairs, modifications, or alterations made by people other than factory or ACI representatives.
- If the product has been abused or damaged due to an accident.
- If repair parts or accessories other than ACI equipment are used on the product; they are warranted only to the extent that they are warranted by the manufacturer of said parts or accessories.

Remarks

EXCEPT AS STATED HERE, ACI MAKES NO OTHER WARRANTIES, EXPRESS OR IMPLIED, INCLUDING WARRANTIES FOR A PARTICULAR PURPOSE.



Alterations or modifications of equipment and use of non-factory repair parts can lead to dangerous operation and injury.

To avoid injury:

DO NOT alter or modify equipment.

DO NOT use equipment to lift, support or otherwise transport people.





DO NOT suspend unattended loads over people.

2.0 SAFETY PRECAUTIONS

2.1 Safety Alert Symbols

Throughout this manual are steps and procedures that can prevent hazardous situations, the following symbols are used to identify the degree or level of hazard seriousness.

DANGER, WARNING AND CAUTION NOTICE

Symbol	Description
	Danger Indicates an imminently hazardous situation which, if not avoided, will result in death or serious injury and property damage.
	Warning Indicates an imminently hazardous situation which, if not avoided, could result in death or serious injury and property damage.
	Caution Indicates a potentially hazardous situation which, if not avoided, may result in minor or moderate injury or property damage.
	Notice Notifies people of installation, operation or maintenance information which is important but not directly hazard related.



Failure to read and comply with any of the limitations noted in this manual can result in serious bodily injury or death, and/or property damage.

This manual contains important information to help you properly install, operate, and maintain the ACI Electric Chain Hoist for maximum performance and safety purposes. Please study the contents thoroughly before putting the hoist in operation. Only through proper installation, application of correct operating procedures, and by practicing the recommended maintenance procedures, can maximum lifting service from the hoist be expected.

The contents of this manual are of necessity, general in nature and may cover features not incorporated on your hoist; or, you may have ordered features not covered by this manual. Therefore, the user must exercise care in applying instructions given in this manual. If specific information not in this manual is required, contact the factory. Follow all instructions and warnings, failure to operate equipment as directed in manual may cause injury.

NOTICE

It is the responsibility of the owner/user to install, inspect, test, maintain, and operate a hoist in accordance with ASME B30.16, Safety Standard for Overhead Hoists, OSHA Regulations, and ANSI/NFPA 70, National Electrical Code. If the hoist is installed as part of a total lifting system, such as an overhead crane or monorail, it is also the responsibility of the owner/user to comply with the applicable ASME B30 volume that addresses that type of equipment used in the system.

Further, it is the responsibility of the owner/user to have all personnel that will install, inspect, test, maintain, and operate a hoist read the contents of the manual and applicable portions of ASME B30.16, Safety Standard for Overhead Hoists, OSHA Regulations, and ANSIIINFPFA 70, National Electrical Code. If the hoist is installed as part of a total lifting system, such as an overhead crane, the applicable ASME B30 volume that addresses that type of equipment must also be read by all personnel. Any ANSI Standards referenced in this manual may be obtained from the American National Standards Institute, 1430 Broadway, New York, NY 10018.

This manual contains information for safe operation of an overhead hoist. Taking precedence over any specific rule, however, is the most important rule of all "USE COMMON SENSE". Operation of an overhead hoist involves more than operating the controls. The operator must consider and anticipate the motions and actions that will occur as a result of operating the controls.

WARNING

These general instructions deal with the normal installation, operation, and maintenance situations encountered with the equipment described herein. The instructions should not be interpreted to anticipate every possible contingency or to anticipate the final system, crane, or configuration that uses this equipment.

This manual includes instructions and parts information for a variety of hoist types. Therefore, all instructions and parts information may not apply to anyone type or size of specific hoist. Disregard those portions of the instructions that do not apply.

Record hoist serial number on the front cover of this manual for identification and future reference to avoid referring to the wrong manual for information or instructions on installation, operation, inspection, maintenance, or parts.

2.2 Important Information and Warnings

- Equipment described in this manual is not designed for and should not be used for lifting, supporting, or transporting humans.
- To ensure the good working order and reliable operation of the hoist keep strictly to the requirements of the maintenance and operation given in this manual.
- Keep strictly to the requirements for safe operation in order to prevent dangers from the personnel and damages to the electric hoist.
- The repairs shall be furnished only with spare parts supplied by the manufacturer.
- Connection of the electric hoist with the power supply shall be furnished only by a qualified electrician.
- Assemblage and putting the electric hoist into use shall only be done by qualified persons, authorized by ACI Hoist and Crane.

- Modifications to upgrade, rerate, or otherwise alter this equipment shall be authorized only by the original equipment manufacturer or qualified professional engineer.

Equipment described in this manual may be used in the design and manufacture of cranes or monorails. Additional equipment or devices may be required for the crane or monorail to comply with applicable crane design and safety standards. The crane designer, crane manufacturer, or user is responsible to furnish these additional items for compliance. Refer to ASME B30.17, Safety Standard for Top-Running Single Girder Cranes; ASME B30.2 Safety Standard for Top-Running Double-Girder Cranes; and ASME B30.11 Safety Standard for Underhung Cranes and Monorails. If a below-the-hook lifting device or sling is used with a hoist, refer to ASME B30.9, Safety Standard for Slings, or ASME B30.20, Safety Standard for Below-the-Hook Lifting Devices.

- Hoists and cranes, used to handle hot molten material may require additional equipment or devices. Refer to ANSI Z241.2, Safety Requirements for Melting and Pouring of Metals in the Metal casting Industry.
- The hoists are not designed to operate in chemically aggressive and explosive environments.
- Failure to read and comply with any of the limitations noted herein can result in serious bodily injury or death, and/or property damage.

Be advised working in or near exposed energized electrical equipment presents the danger of electric shock.



HAZARDOUS VOLTAGES ARE PRESENT IN THE CONTROL ENCLOSURE, OTHER ELECTRICAL COMPONENTS AND CONNECTIONS BETWEEN THESE COMPONENTS.

Before performing ANY mechanical or electrical maintenance on the equipment, DISCONNECT the main switch supplying power to the equipment; and implement LOCKOUT/TAGOUT procedure. Refer to ANSI Z244.1, Personnel Protection - Lockout/Tagout of Energy Sources.

Do not operate the equipment without control enclosure cover or covers in place.

2.3 Safe Hoisting and OSHA Compliance

The following is a list of the minimum that should be done to keep the hoists and cranes operating properly, safely, and within OSHA regulations. The following should be done to all hoisting equipment including hand and ratchet hoists.

1. Operator Training: Like forklifts and trucks, operator training is required for every operator of hoisting equipment (OSHA 1910.179 b.8). Improper lifts are a major cause of lost time accidents. People operating hoisting equipment must know how to use the equipment safely.
 - ACI offers operator-training classes. Classes include; safe rigging, daily equipment inspection, safe operation, proper use and what can happen with improper use. Classes typically last 1.5 to 2 hours and can be given in English or Spanish.
2. Preventive Maintenance: A preventative maintenance (PM) program shall be established based on the manufacturer's recommendations (ANSI B30 .16 2.3 .1a; OSHA 1910.179 Lj).
 - ACI offers a PM program based on manufacturers recommendations. ACI has factory-trained technicians that utilize the proper equipment to do the job correct, fast, and safe. ACI does not charge for rental of man lifts or forklifts that must be used to operate safely.
3. Qualified Repair Personnel: Adjustments and repairs should be performed by qualified personnel (ANSI B30.16 16-2.3.3 b).

4. Daily Inspections: Many items must be checked on a daily basis. Written records do not need to be kept for these inspections (OSHA 1910.179 j 1; ANSI B30.16).
 - ACI provides operator-training classes to perform these inspections. These quick inspections are completed to verify the unit is safe to use prior to daily operation.
5. Frequent Inspections: These inspections are written inspections required on a monthly basis. (OSHA 1910.179 j1; ANSI B30.16).
 - ACI can provide these inspections or provide training for your personnel to conduct these inspections.
6. Periodic Inspections: These are complete inspections and preventative maintenance of the hoists and cranes. Qualified personnel should determine inspection interval. These should include brake adjustment and lubrication as well as a complete written inspection of your equipment. (OSHA 1910.179 j 2; ANSI B30.16).
 - Based on use and environment ACI can provide these inspections anywhere from a monthly to an annual basis. The inspections are designed to maintain the equipment and reduce the long-term maintenance costs.
7. Records: Dated inspection records shall be kept for inspections and maintenance. (ANSI B30.16 16-2.1.1.2). Records should be kept where easily available. An external marking is acceptable in lieu of records.
 - ACI provides the necessary records. We also keep a copy of all records for your convenience.
8. Load Test: New equipment or equipment that has repairs or alterations to the load handling portion must be load tested to 125% of rated load. (ANSI B30.16 16-2.2.2). A load test should be performed at a minimum of every 4 years (CMAA 78 4.7.4). Load test records must be kept for the life of equipment.
 - ACI has certified test weights to test your hoists and cranes.

NOTE: There are many special requirements for hoisting systems that should be verified during the design and inspection of the equipment. It is extremely important for safe operation that the system is designed and maintained by qualified personnel. ACI would be pleased to provide this service.

2.4 Warning Tags and Labels

The warning tag illustrated below is supplied with each hoist shipped from the factory. If the tag is not attached to your hoist's pendant cord, call ACI Hoist & Crane immediately to receive it and install it. Read and obey all warnings attached to this hoist. Tag is not shown in actual size.

**ONLY QUALIFIED PERSONNEL
SHALL OPERATE THIS EQUIPMENT**

DO NOT:

- Remove, deface or obscure this label.
- Operate malfunctioning equipment.

BEFORE OPERATING

DO:

- REPORT condition for repair by qualified person.
- READ Mfr's. Instruction. Applicable American national Safety Standards.
- CHECK ROPE OR CHAIN
 - Must be seated in grooves, sheaves or sprockets.
 - Must not be twisted, kinked or damaged in any way.
- CHECK CONTROLS
 - All limit switches must function properly
 - Hook travel must be in the same direction as shown on controls.
- CLEAR all personnel from service platform and path of load.

WHILE OPERATING

DO NOT:

- Lift more than rated load.
- Lift people or loads over heads of people.
 - WARN personnel of approaching loads.
- Make side pulls, Lift all loads vertically.
- Use limit switches as routine operating stops.
 - THESE ARE EMERGENCY DEVICES ONLY
- Operate if rope (or chain) slips from grooves (or sprockets). REPLACE in grooves (or sprockets) before continuing operation.

BEFORE LEAVING OPERATING POSITION

- DO NOT leave a load suspended and unattended.
- ALWAYS disconnect from power supply when equipment is not in use.

ACI
Call: (954)367-6116
WWW.ACIHOIST.COM

2.5 General Safe Operation Requirements



Before installing, removing, inspecting, or performing any maintenance on a hoist, the main switch shall be de-energized. Lock and tag the main switch in the de-energized position in accordance with ANSI Z244.1.

Follow other maintenance procedures outlined in the manual and applicable ASME B30 volumes.

Additional WARNINGS are listed in various portions of this manual. Personnel shall read and follow these WARNINGS. Failure to read and comply with these WARNINGS as well as other instructions or any limitations noted in this manual and applicable ASME B30 volumes could result in serious bodily injury or death, and/or property damage.

- Read and observe the instructions and warnings contained in this manual. Read and observe any instructions and warning tags attached to the hoist.
- Check for any damage to the hoist during shipment. Check carefully to ensure the cable, gearbox, and motor shell are not damaged. If any damage has occurred, place a claim with the carrier. DO NOT install a damaged hoist.
- Check that the crane, monorail, or other supporting structure where the hoist will be installed has a load rating capable to handle loads equal to the rated load capacity of the hoist.
- Check lubricant in gear housing. Oil level should be even with oil level plug in housing. If additional gear housing lubricant is required, refer to the LUBRICATION section of this manual. Lubricate any exposed gears and pinions on the trolley.
- Be certain the power supply to the hoist and trolley have the same voltage, frequency, and phase that are specified on the hoist and trolley nameplate.

Every hoist should be equipped with the following standard accessories:

- One Chain Container
- Control Cable
- One Control Station

Before using the hoist, fill in the information below:

Model Number: _____

Serial Number: _____

Purchase Date: _____

Installation MUST be performed by a qualified person in accordance with ACI Hoist & Crane. Severe injury, death and/or property damage can result if the hoist is not correctly installed. For service in this area, please contact:

ACI Hoist & Crane
2721 NE 4th Ave
Pompano, FL 33064
Phone: 954-367-6116
Fax: 954-272-0334
Toll Free: 1-866-424-6478

3.0 GENERAL DESCRIPTION & FEATURES

3.1 Model Numbering

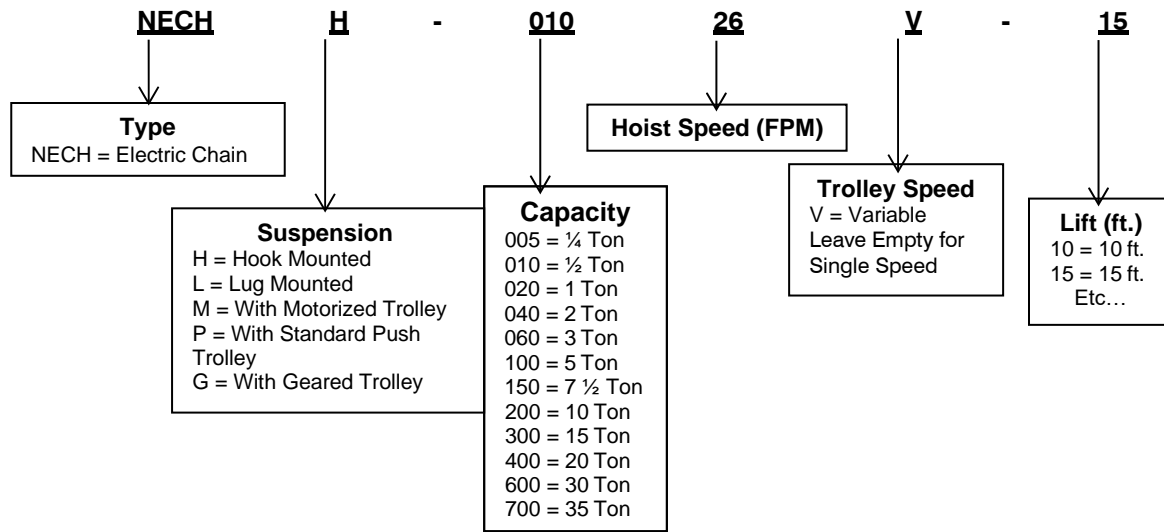

3.2 Pendant Control

Pendant stations are provided fully assembled. When using a pendant control, depress the up button to raise the hoist or the down button to lower the hoist as shown in Figure 3.5.1 below. To stop motion, release the buttons.

! CAUTION

Ensure the motor comes to a complete stop before reversing the direction.



Figure 3.2.1

Push Button Station Dimensions
Table 3.2.2

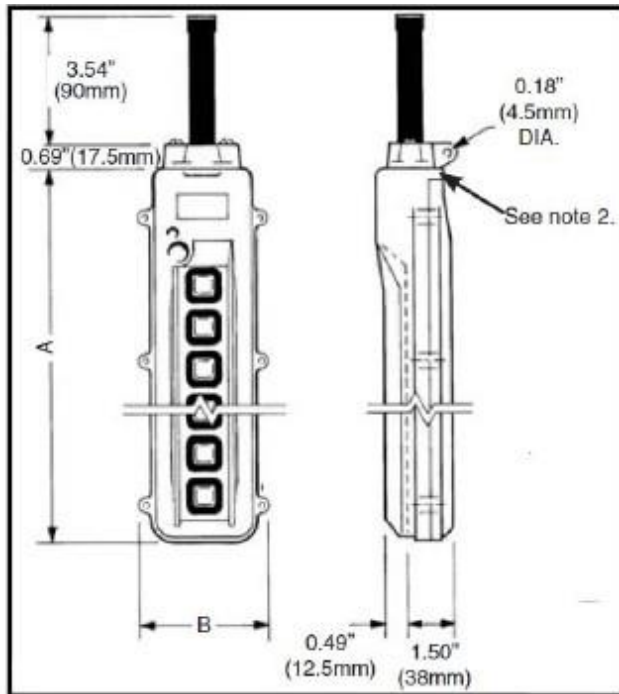

No of positions	A		B	
	(in)	(mm)	(in)	(mm)
2	4.49	114	3.07	78
4	7.09	180	3.07	78
6	10.31	262	3.23	82
8	12.68	322	3.23	82
10	15.24	387	3.43	87
12	17.60	447	3.43	87
12-24	See note 1			

Note 1: Please consult the factory for custom design.

Note 2: Bushing collar can be mounted facing front or rear

Bushings

Cable bushing	Cable size	
	Diameter (mm)	Diameter (in)
100COBA1	7.5 – 10.5	.30 - .41
100COBA2	10.3 – 13.5	.41 - .53
100COBB1	13.3 – 16.5	.52 - .65
100COBB2	16.3 – 19.5	.64 - .77
100COBC1	19.3 – 22.5	.76 – 89
100COBC2	22.3 – 25.5	.88 – 1.00
100COBD1	25.3 – 28.5	1.00 – 1.12
100COBD2	28.3 – 29.5	1.11 – 1.16

4.0 INSTALLATION

ACI electric hoists are lubricated and tested before being shipped from the factory. To place a hoist in service, install the hoist onto a beam by adjusting the hoist appropriately for the flange width. Then connect it to an electrical service and perform pre-operation tests, checks and inspections.

WARNING

Only qualified personnel with proper supervision shall install the hoist on the monorail and perform the final pre-operation inspection.

Before installing, removing, inspecting, or performing any maintenance on a hoist, the main switch shall be de-energized. Lock and tag the main switch in the de-energized position in accordance with ANSI Z244.1.

Follow other maintenance procedures outlined in this manual and applicable ASME B30 volume(s). Additional WARNINGS are listed in various portions of this manual. Personnel shall read and follow these WARNINGS. Failure to read and comply with these WARNINGS as well as other instructions or any limitations noted in this manual and applicable ASME B30 volumes could result in serious bodily injury or death, and/or property damage.

4.1 Prior to Installing Hoist

CAUTION

Prior to installing the hoist check for any damage that may have occurred to the hoist during shipment.

DO NOT install a damaged hoist.

- Read and observe the instructions and warnings contained in this manual. Read and observe any instructions and warning tags attached to the hoist.
- Locate any vent plugs attached to or included with the hoist and trolley. Remove solid shipping plug or plugs.
- Check that the crane, monorail, or other supporting structure where the hoist will be installed has a load rating capable to handle loads equal to or greater than the rated load capacity of the hoist.
- If hoist is to be installed on an existing crane, the crane should be run to a location where it will cause the least interference with other cranes and operations in the area; and all controllers placed in the off position.
- If the hoist is to be installed on an existing crane, and the crane runway remains energized because of other cranes operating on the same runway; stops or a signal person(s), located full-time at a visual vantage point for observing the approach of active crane(s), shall be provided to prohibit contact by the active crane(s) with the idle crane.
- If personnel will be required to work on the runway during installation, a guard or barrier shall be installed between adjacent runways for the length of the established work area to prevent contact between persons performing installation and a crane on the adjacent runway.

- If personnel are required to work at elevations in excess of 6 feet above floor or ground level, a fall prevention policy and procedure shall be developed, documented, and implemented prior to installation.
- Check power supply that will be furnished to the hoist and trolley. It must be the same as shown on the hoist and trolley serial plate.
- Check load chain for damage. Be sure load chain is properly seated in load sheave and sheave pockets.
- After repair and reassembling of the electric hoist check the phasing and the limit switch adjustment for upper and lower position of the loading hook.
- While conducting maintenance and repair activities for electric repairs/maintenance, make sure that there is no load on the hook; the power supply switch is turned off and unauthorized switching on is eliminated.
- Check the loading hook for cracks and deformities as well as the good working order of the fuse for self-release of the load.
- Check the connection of cable protective conductors to the grounding terminals in the electric board as well as the transformer and electricity.
- If the hoist has a trolley, check that the crane bridge beam or monorail beam is level, straight, and clean. Check that trolley stops are installed, or install trolley stops, at the open end or ends of the beam to prevent the trolley from traveling off the beam. Trolley stops that engage trolley wheels are not recommended. Check that trolley stops will prevent overhanging parts of the hoist and trolley from interfering with other equipment beyond the ends of the beam or monorail.

⚠ WARNING

The main switch (disconnect) supplying power to the crane, monorail, or other piece of equipment where the hoist is to be installed, shall be de-energized. Lock and tag the main switch in the de-energized position in accordance with ANSI Z244.1.

4.2 Installation of Hoist

Prior to mounting the hoist ensure that the suspension and its supporting structure are adequate to support the hoist and its loads.

- **Hook Mounted** – Attach the hoist’s top hook to the fixed suspension point. Ensure that the fixed suspension point rests on the center of the hook’s saddle and that the hook’s latch is engaged.
- **Lug Mounted** – Fasten securely with lug suspension pins. Check that there are no obstructions to the operation of the hoist including the path of the chain. Use only the lug mounting hole for suspension of the hoist.
- **Under Running Trolley Hoist Unit** - Trolley is mounted on hoist and shipped as one unit. Trolley will operate on standard S-shapes or W-shapes flanges.

4.2.1 Installation of Hoist with Trolley

If the trolley hoist is mounted on a skid, do not remove it immediately. The skid will hold the trolley hoist unit in an upright position until assembled on the crane or monorail.

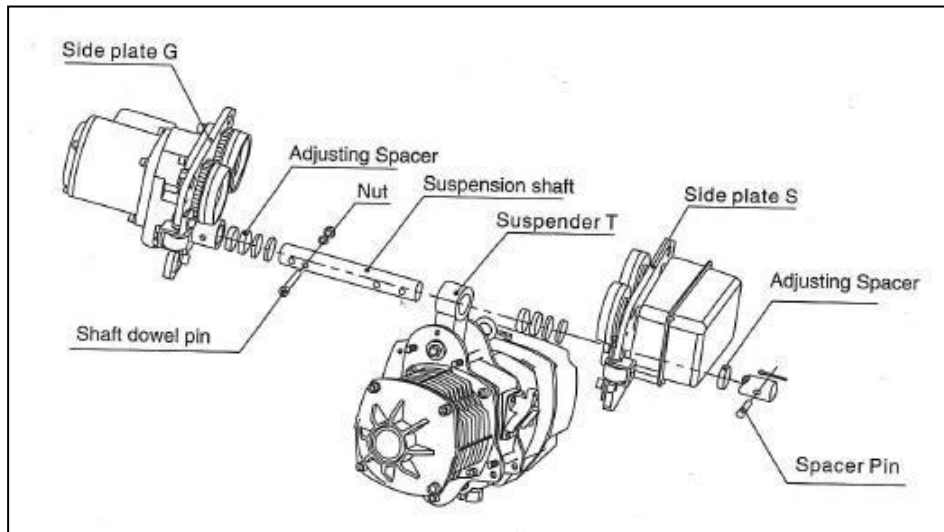

Figure 4.2.1.1

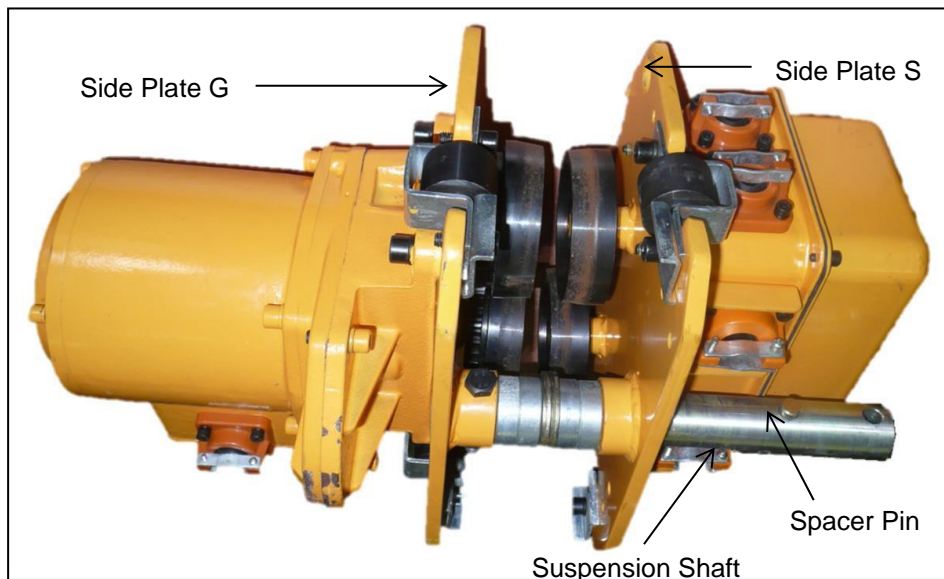

Figure 4.2.1.2

1. Remove cotter pin from trolley shaft dowel pin (Spacer Pin) and slide suspension shaft out of side plate S (refer to Figures 4.2.1.3 and 4.2.1.4).



Figure 4.2.1.3



Figure 4.2.1.4

2. Measure the flange width of the beam where the trolley is to be installed.
3. Slide one stack of inner adjusting spacer over the suspension shaft. Total width should be about half of the flange width of the beam. Then insert suspension shaft into suspender T (refer to Figure 4.2.1.5).



Figure 4.2.1.5

4. Slide same size of inner adjusting spacer stack next to the suspender T and install side plate S to the suspender shaft (refer to Figure 4.2.1.6).



Figure 4.2.1.6

5. Secure the shaft with spacer pin and cotter pin.
6. Refer to Figure 4.2.1.7 for adjusting the width of the trolley by installing inner and outer adjusting spacers on the suspension shaft.

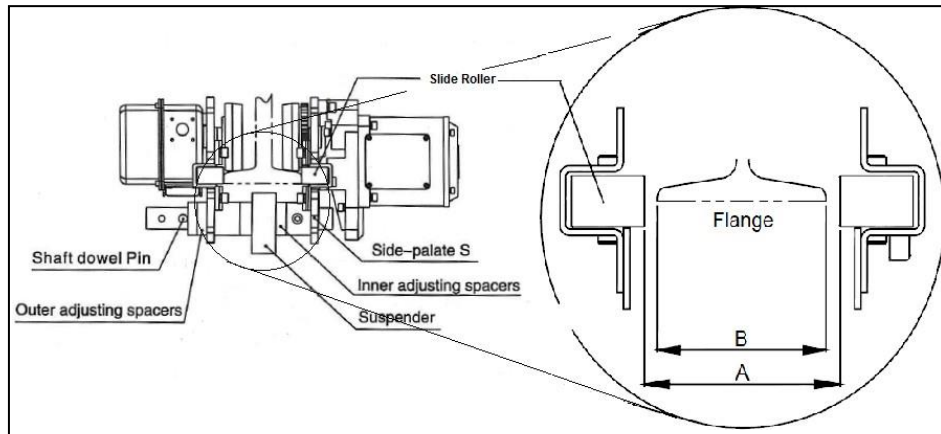

Figure 4.2.1.7

7. Make sure both side plates are spread fully outward and measure dimension "A". Dimension "A" must be $\frac{5}{32}$ " (4 mm) greater than "B" (refer to Figure 4.2.1.7).
8. Rearrange spacers, if necessary, to achieve proper spacing. Distribute washers equally so that the hoist will be centered between trolley side plates and under beam.
9. After obtaining the proper adjustment, secure the shaft with spacer pin and cotter pin.

Even if the unit was ordered for a specific beam size or beam flange width; check trolley wheel spacing between wheel flanges.

4.2.2 Installation of Trolley Hoist on the Beam

1. Place trolley hoist in correct position relative to bridge beam or monorail, orienting it for proper end approach in accordance with specification requirements. Be sure that collectors and conductors are properly positioned and aligned.
2. Place Trolley hoist unit in position on bridge beam or monorail. Check that trolley bumpers, if provided, meet trolley stops on beam, reposition if necessary.

The simplest ways to mount the trolley hoist on the beam, as long as the crane or building construction permits it, is to remove the trolley stops on an open end of the beam, run the trolley onto the beam and replace the trolley stops. If this method is not possible due to crane or building interference, mount the trolley hoist according to the following instructions (refer to Figure 4.2.2.1).

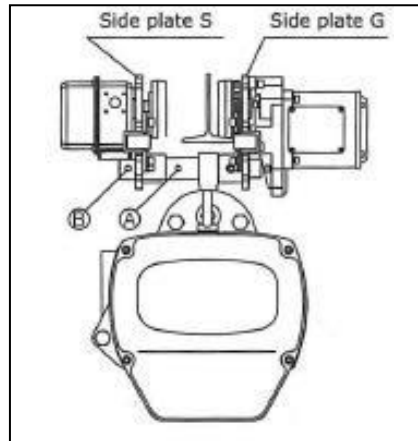

Figure 4.2.2.1

3. Remove side plate assembly, with the wheels intact, from one side of the trolley only, by removing the spacer pin from the suspension shaft hole A. Then insert it into hole B. Insert cotter pin in the spacer pin to fix it in place. On geared and motorized trolleys it is recommended that the side with the plain wheels be removed.
4. Spread side plate G and side plate S apart. Lift the trolley up to the beam; keep both sides of the wheel and beam at the same level.
5. Support one side plate then push the other side towards the supported side to prevent it from shedding from the beam. Keep the wheel and the beam at the same level.
6. Remove the spacer pin from hole B and insert it into hole A. Secure the spacer pin with the cotter pin.
7. Check that the hoist is centered between trolley side plates and centered under the beam.
8. The load block must hang straight and directly under the hoist. The load chain must be free of kinks, twists or any other damage.

⚠ WARNING

If the load chain welding points are not inline you must replace the load chain before use.

Trolley hoists are balanced at the factory based upon the condition of the hoist “as ordered” and “as shipped”. Auxiliary equipment or devices furnished and mounted by others may require additional counterweights to balance the hoist. It is the responsibility of the party mounting such auxiliary equipment or devices to add additional counterweights as necessary and required.

4.2.3 Connecting Power Supply to Hoist

! DANGER

Disconnect power and lockout and tag the power before connecting the power supply to the hoist to prevent accidental application of power.

Only a qualified person should connect the power supply to the hoist.

Check the power supply that will be connected to the hoist to ensure that it is the same voltage as shown on the hoist serial number plate. If the power supply that will be connected to the hoist is not the same as shown on the hoist serial number plate, **DO NOT** connect the power supply to the hoist. Make all electrical connections in accordance with the wiring diagram on page 65.

4.2.4 Load Chain

After installation of hoist to the beam check the load chain utilizing the following steps:

1. Check the location of the welding points on the chain. All welds should be inline (refer to Figure 4.2.4.1).
2. Check for twists and kinks in the chain (refer to Figure 4.2.4.2).
3. Raise the load block without a load to within three feet of driving load sheave.
4. Check the direction of the chain movement, for example, if you press up on the pendant the chain should raise.

! WARNING

If load chain is damaged, DO NOT use hoist until load chain is replaced.

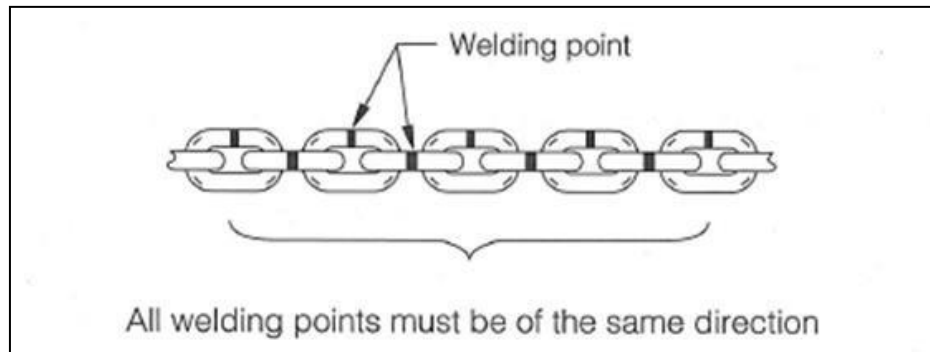

Figure 4.2.4.1

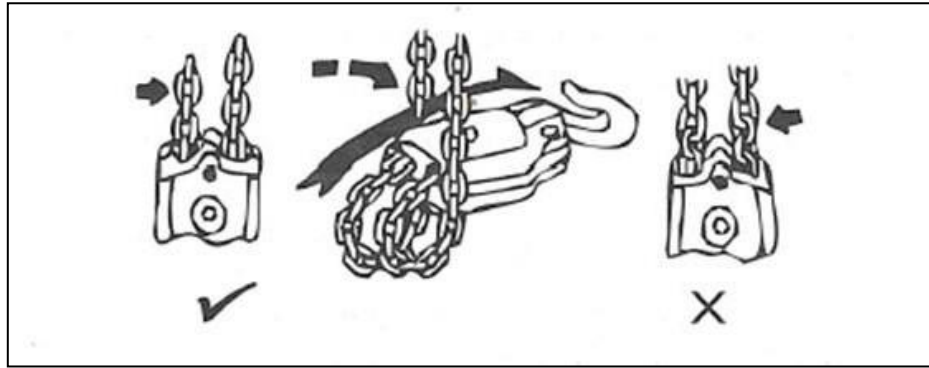

Figure 4.2.4.2

At this time the chain container should be installed utilizing the following procedures:

1. Lower hoist hook until lower limit switch stops downward motion of hook.
2. Place container on hoist and secure it in place with the chain container pins and cotter pins. Orient the container as shown in Figure 4.2.4.3.
3. Place loose end of chain with chain stop into the container. The loose end of the chain should flow into the container.

DO NOT use a chain container with a storage capacity less than the lift length on the hoist (refer to Table 4.2.4.1)

Table 4.2.4.1 Chain Bag Dimensions

Model Number	Chain Length (Ft.)	Size of Chain Bag (In.)	Material
8#	< 19.7	5.9 x 5.9 x 7.9	Canvas
8#	< 28.9	5.9 x 5.9 x 11.8	Canvas
12#	26.2 – 52.5	8.3 x 8.3 x 17.7	Canvas
14#	26.2 – 52.5	8.3 x 8.3 x 17.7	Canvas
Other	> 65.6	/	Steel

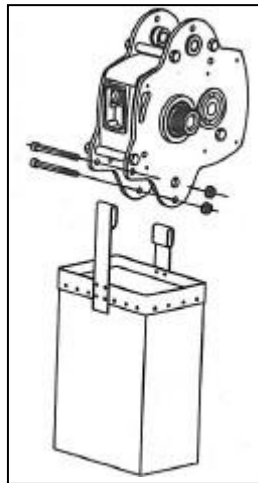

Figure 4.2.4.3

4.3 Prior To Operation

- Before energizing the power supply, and inspecting and testing the hoist prior to initial operational use, check that all electrical connections are in accordance with the wiring diagram.
- ASME B30.16 requires that all new, altered, or modified hoists be inspected by a designated person prior to initial use to verify that the equipment and installation comply with applicable provisions of the standard. Such an inspection should be performed at this time, using ASME B30.16 as the basis for inspection procedures.
- Energize the power supply to the hoist

4.3.1 Motor Phasing

Since motor rotation of a three-phase AC motor can be changed by reversing any two of the lines feeding power to the motor, the direction of the hook motion must be checked to verify that it is correct in accordance with the hoist control device markings. For example, when pressing up on the hoist pendant the chain should ascend.

To check hook motion direction and/or motor phasing do the following:

WARNING

DO NOT activate the down button of the hoist control device. If the hoist motor is improperly phased, hook will move up and cause possible damage to the hoist.

MOMENTARILY activate the **UP** button of the hoist control device and observe the direction of the hook motion. If the direction of the hook travel matches the direction marking of the hoist control device button activated then the hoist motor is properly phased. If the direction of the hook travel does not match the direction marking of the hoist control device button activated, for example when you press UP the hook descends; then the hoist motor is improperly phased and must be corrected. **DO NOT** use the hoist until motor phasing is corrected.

WARNING

DO NOT operate the hoist if the direction of the hook travel and the marking on the hoist control device activated **DO NOT** match.

WARNING

DO NOT attempt to correct an improperly phased hoist by changing any wiring in the hoist control device or at the hoist connectors; or by changing the markings on the hoist control device.

Utilize the following steps to correct hoist motor phasing:

DANGER

1. Disconnect the power, lockout and tagout the power supply before working on the electrical wiring to prevent accidental application of power.
2. Only a qualified person should disconnect or connect the power lines to the hoist.

3. Interchange any two lines supplying power to the hoist.
4. Re-energize power supply to the hoist.
5. Check the hoist travel direction for correct hook motion by pressing **UP** on the hoist control device. If the direction of the hook travel matches the direction marking of the hoist control device button activated then the hoist motor is properly phased. If the direction of the hook travel does not match the direction marking of the hoist control device button activated the hoist motor is improperly phased and must be corrected by repeating steps 1 through 5.

4.3.1 Trolley Motor Phasing

If the hoist has a motorized trolley please see the trolley's operation manual for proper motor phasing.

4.4 Testing Limit Switches

All testing of limit switches should be accomplished without a load on the hook of the hoist. All tests should be accomplished by using the low speed of variable-speed hoists, or inched into the limit if the hoist is a single-speed unit. Before checking limit switches the function of limit rocker arms should be checked by pushing the rocker arms up and down to ensure they function properly.



Never operate the hoist without the protection of properly functioning limit switches.

Hoist limit switches shall **NOT** be used as a normal means of stopping travel motion or the load; these are emergency devices only.

The primary upper and lower limit switch should be checked without a load on the hook at the start of each shift, or before the first time the hoist is to be operated during each shift.

These instructions apply to limit switch adjustment for an unloaded load block only. Limit switches must be adjusted to prevent the load block or the load being lifted from coming into contact with any part of the hoist, crane, hoist support structure, or other equipment where the hoist is installed.

To check lower limit device, operate the hoist in the lowering direction until motion of the load block stops. While lowering the load block, watch the length of the load chain on the unloaded side of the hoist. If the loop will become taut before the lower limit device stops load block motion, **STOP** the hoist motion, the lower limit device requires adjustment. The hoist lower limit device is set at the factory to stop lower travel of the load block with approximately nine to fifteen (9-15) links of load chain extending beyond the chain guide on the unloaded side of the hoist. It is recommended that the lower limit device be set to prevent the load block from resting on the floor and allowing the load chain to go slack. If adjustment of the lower limit device is required, refer to the Limit Switches section of this manual.

To check upper limit device, operate the hoist in the lifting direction to a point where the block is about 12 inches below the hoist. If the hoist has more than one speed, continue to raise the load block at low speed or if hoist is a single speed unit inch the load block in the lifting direction until motion of the load block stops. If the load block will hit the hoist or hoist frame before the upper limit device stops the load block motion, **STOP** the hoist motion, the upper limit requires adjustment. If adjustment of the upper limit device is required, refer to the Limit Switches section of this manual.

1. Operate the hoist without a load on the hook through the entire lifting range to ensure that the limit switches function properly and that the load block and hook do not interfere with any other items or pieces of equipment located in the operating area.

2. If the hoist has a trolley, operate the trolley without a load on the hoist hook for the entire travel distance of the trolley to ensure that the trolley, hoist, load block and hook do not interfere with any other items or pieces of equipment located in the travel path.

The hoist is now ready to be load tested, if required.

4.5 Hoist Load Test

Complete hoists are load tested by Manufacturer in accordance with ASME B30.16. If the hoist is installed on a crane, load testing of the crane in accordance with, as applicable, ASME B30.2, ASME B30.11, or ASME B30.17 may be required.

Prior to operating hoist for the first time, the hoist should still be test operated, as follows, with a load on the hoist hook.

1. Attach a load to the hoist hook. Load shall not exceed the rated load capacity of the hoist.
2. Before lifting the load, operate the hoist in the raising direction to take any slack out of the hoist load chain.
3. Raise the load a few inches and stop the hoist. If brakes stop and hold the load, continue raising and lowering the load several feet, stopping the hoist several times in each direction to check that the hoist braking system stops and holds the load.
4. If the hoist braking system stops and holds the load, the hoist operates in accordance with the control devices, and no unusual sounds are present during operation, the hoist is ready to be released for operating purposes.
5. If the hoist braking system does not stop and hold the load, the hoist does not operate in accordance with the control devices, or any unusual sounds are present during operation, the hoist is not ready to be released for operating purposes; corrective action must be taken.

5.0 OPERATION

The operator of the hoist must be well acquainted with this manual and be instructed on the requirements for safe operation. The operator's clothing should be in accordance with working conditions. The operator should always have at hand the operation manual or a copy of the Operation and Safety sections, which must be placed near power circuit breaker or on an easy and accessible place.

All personnel that will operate the hoist shall read the Operation section of this manual, the **DANGER**, **WARNING**, **CAUTION**, and **NOTICES** contained in this manual, and instruction and labels on the hoist before operating the hoist or lifting system.

Operation of an overhead hoist involves more than activating the buttons of the hoist control device. It is emphasized in ASME B30 Safety Standard that the use of overhead hoists is subject to certain hazards that cannot be met by mechanical means, but only by the exercise of intelligence, care, common sense and experience in anticipating the motions that will occur as a result of activating the hoist controls. Certain precautions are necessary before moving the load and this includes the proper rigging of loads to the hoist hook.

WARNING

Hoist operators **SHALL** be required to read the operation section of this manual, the **DANGERS**, **WARNINGS**, **CAUTIONS** and **NOTICES** contained in this manual, operation instructions and labels on the hoist or lifting system, and the operation section of ASME B30.16, and to be familiar with the hoist and hoist controls before being authorized to operate the hoist or lifting system.

Hoist operators should be trained in proper rigging procedures for the attachment of loads to the hoist hook.

Hoist operator should be trained to be aware of potential malfunctions of the equipment that require adjustment or repair, instructed to stop operation if such malfunctions occur, and immediately advise their supervisor so corrective action may be taken.

Hoist operators should have normal depth perception, field of vision, reaction time, manual dexterity, and coordination.

Hoist operators should not be subject to seizures, loss of physical control, physical defects, or emotional instability that could result in actions of the operator being a hazard to the operator or others.

Hoist operators should not operate a hoist or lifting system when under the influence of alcohol, drugs, or medication.

Overhead hoists are intended only for vertical lifting service of freely suspended unguided loads. Do not use hoist for loads that are not lifted vertically, loads that are not freely suspended, or loads that are guided.

5.1 General Safety

Safe operation of an overhead hoist is the operator's responsibility. Listed below are some basic rules that can make an operator aware of dangerous practices to avoid and precautions to take for his or her own safety and the safety of others. Observance of these rules, in addition to frequent examinations and periodic inspection of the equipment, may save injury to personnel and damage to equipment.

- The operator shall know hand signals used for hoist and crane operations, if a signalperson is used in the operation, and accept signals of only persons authorized to give hand signals **EXCEPT** to obey a stop signal regardless of who gives it.
- The operator shall **NOT** adjust or repair a hoist unless qualified and authorized to perform maintenance.
- The operator shall **NOT** use the hoist load limiting devices as a means to measure the load.

5.1.1 General DOs and DON'Ts

- **DO** establish a regular inspection schedule and maintain a record of all inspections performed with special attention directed to the chain, hooks, and breaks.
- **DO** remove the hoist from service and perform necessary maintenance and repair.
- **DO** follow recommended maintenance procedures for taking a hoist out of service to inspect and perform maintenance and repair.
- **DO** use the original hoist manufacture's recommended parts when repairing a hoist and replacing worn or damaged parts.
- **DO NOT** allow unqualified or unauthorized personnel to operate, inspect, maintain, or repair the hoist.
- **DO NOT** operate a hoist that is damaged or has any actual or suspected mechanical or electrical malfunction.
- **DO NOT** use the chain, any part of the hoist, or the load block and hook as a ground for welding.



DO NOT walk under a suspended load.

DO NOT perform any work on a suspended load that requires a worker to be positioned under the suspended load.

If it is essential that a worker be positioned under a suspended load to perform work on the suspended load, such work shall not be started or performed until other auxiliary supporting means are placed under the suspended load. Failure to use other auxiliary supporting means could result in serious bodily injury or death, and/or property damage.

5.2 Safety Rules before Operating the Hoist

- Be familiar with all operating controls of the hoist.
- Be familiar with the operation procedures of this manual, the **DANGERS, WARNINGS, CAUTIONS** and **NOTICES**, also the procedure of instructions and labels on the hoist and lifting system.
- **DO NOT** operate the hoist if any damage or malfunctions exist or are suspected to exist. All suspected or actual malfunctions and damage **SHOULD** be reported to the supervisor.
- **DO NOT** operate if tagged with an out of order sign.
- **DO NOT** use the hoist load chain as a sling to wrap around the load.
- Attach the load to the hoist hook by proper means such as slings or lifting devices.

- Only attach a load to the hoist hook that does **NOT** exceed the rated load capacity of the hoist.
- Confirm that the size of the attachment of the sling or other lifting device to be used is compatible to the size of the hoist hook.
- Confirm that the attachment part of the sling or other lifting device is properly seated in the base, bowl, or saddle of the hoist hook.
- Confirm that the hook latch operates properly and that the hook latch properly bridges and closes the hook throat opening.
- Confirm that the latch of the hoist hook will not support any part of the load.
- Confirm that the load or any part of the load will not be applied to and/or not supported by the tip of the hook.
- Confirm that the load will be properly balanced when lifted.
- Confirm that the hoist load chain is not kinked or twisted, and that the load chain parts are not twisted around each other.
- Confirm that the hoist load chain is properly seated in the load sheave and sheave pockets.
- Notify personnel in the area that a load will be lifted and verify that all personnel are clear of the load.
- Confirm that when the load is lifted, it will clear all material, machinery, or other obstructions in the area.

5.3 Safety Rules for Operating the Hoist

- **DO NOT** engage in any activity that will divert the attention of the operator.
- **DO NOT** lift, lower, or transport a load and hoist until the operator and all other personnel are clear of the load and the path of the load.
- Confirm that the load a hoist will clear all obstacles before moving or rotating the load.
- Avoid moving loads over personnel.
- **DO NOT** lift, lower, or transport personnel by the hoist, trolley, hoist hook, or load.
- Slowly inch the hook into engagement with the load to eliminate wire rope slack and reduce impact loading of the hoist.
- Avoid unnecessary inching and quick reversals of direction.
- Only lift the load a few inches to confirm that the load is properly balanced before continuing with the lift.
- Only lift the load a few inches to confirm the hoist braking system is functioning properly before continuing with the lift.
- Avoid swinging of the load or hoist hook when the hoist is travelling.
- Avoid sharp contact between trolleys or between trolleys and stops.
- **DO NOT** use hoist limit switches or devices as a normal means of stopping the hoist.

5.4 Safety Rules for Parking the Load

- **DO NOT** lower a load with the hoist until the operator and all other personnel are clear of the load and the path of the load.
- Confirm that the load will clear all obstacles before lowering the load.

- Block loads before landing if slings or other lifting devices must be removed from under the landed load.
- Exercise care when removing a sling from under a landed and blocked load.
- **DO NOT** leave a suspended load unattended unless specific precautions to prevent the load from inadvertently lowering have been instituted and are in place.
- Position the hoist load block and hook above head level for storage when the hoist is not in use.

5.5 Safety Rules before Each Shift

- Visually inspect the load chain for nicks, gouges, and any type of deformation or damage to the load chain. Check for lubrication of load chain.
- Visually inspect the hooks for nicks, gouges, deformation of the throat opening, and wear on saddle or load bearing point and twisting.
- Visually inspect the hook latches for proper operation or damages that do not allow proper operation.
- Replace warning labels if missing or illegible.
- Report any damage or malfunctions to the supervisor.
- **DO NOT** operate the hoist if any damage or malfunctions exist.
- **DO NOT** operate the hoist if it is tagged with an out of order sign.

6.0 INSPECTION

All ACI hoists are inspected and tested at the factory. Regular in-service inspection and preventative maintenance programs not only help reduce overall maintenance costs but may also prevent service shutdowns by forewarning of problems that could arise and cause a shutdown. Regular inspections, periodic minor adjustments, regular cleaning, lubrication, and replacement of worn parts can help maintain the hoists performance and operation in good order.

Hoists shall be maintained, inspected and tested in accordance with this manual and in accordance with the intervals and requirements of ASME B30.16. Cranes shall be maintained, inspected and tested in accordance with the manual furnished by the crane manufacturer and in accordance with the intervals and requirements of, as applicable, ASME B30.2, ASME B30.11, or ASME B30.17. The following definitions are from ANSI/ASME B30.16 and pertain to the inspection procedures below.

- **Designated Person** – a person selected or assigned as being competent to perform the specific duties to which he/she is assigned.
- **Qualified Person** – a person who, by possession of recognized degree or certificate of professional standing, or who, by extensive knowledge, training and experience, has successfully demonstrated the ability to solve or resolve problems relating to the subject matter and work.

Definitions of service from ASME B30.16 are as follows:

- **Normal Service** – service which involves operation of the hoist with randomly distributed loads within the rated load limit, or uniform loads less than 65% of rated load, for not more than 25% of the time for a single work shift.
- **Heavy Service** – service which involves operation within the rated load limit which exceeds normal service.
- **Severe Service** – service which involves normal to heavy service with abnormal operating conditions.

6.1 Prior to Maintenance or Inspection

Before maintenance or inspections are performed on a hoist, trolley or crane the following precautions shall be taken as applicable.

- The hoist, trolley, or crane to be inspected, tested or repaired shall be run to a location where it will cause the least interference with other hoists, cranes and operations in the area.
- If a load is attached to the hoist hook, it shall be landed.
- All controllers shall be placed in the off position.
- If the hoist is trolley suspended, the trolley shall be blocked to prevent trolley movement.
- If the hoist is installed on a crane, the crane shall be blocked to prevent crane movement.



Hazardous voltages are present in the control box, other electrical components and connections between these components.

The main switch (disconnect) of the hoist, crane or lifting system shall be de-energized. Lock and tag the main switch in the de-energized position in accordance with ANSI Z244.1.

- Warning signs and barriers shall be utilized on the floor beneath the hoist, crane or lifting system where overhead maintenance, repair or inspection work creates a hazardous area on the floor beneath the hoist, crane or lifting system.
- If the crane runway or monorail remains energized because other hoists or cranes are on the same runway or monorail are in operation, rail stops or a signal person(s) shall be located full-time at a visual vantage point for observing the approach of an active hoist(s) or an active crane(s) to prohibit contact by the active hoist(s) or crane(s) with the idle hoist or crane, persons performing maintenance, repair or inspection and equipment used in performing maintenance, repair or inspection.
- A guard or barrier shall be installed between adjacent runways for the length of the established work area to prevent contact between persons performing maintenance, repair, or inspection and a crane on the adjacent runway.
- Safe Access to the hoist, crane or lifting system, such as, scaffolding, work platforms, etc., shall be provided for personnel that will perform maintenance, repair or inspection. If personnel are required to work at elevations in excess of 6 feet above floor or ground level, a fall prevention policy and procedures shall be developed, documented and implemented by the owner/user.
- After maintenance, repair, or inspection work is completed, and before the hoist, crane or lifting system is returned to normal operation:
 - Any guards on the hoist, crane or lifting system that were removed to perform maintenance, repairs or inspection work shall be reinstalled.
 - Any safety devices on the hoist, crane or lifting system that were deactivated to perform maintenance, repair or inspection work shall be reactivated.
 - Any parts that were replaced and other loose material shall be removed.
 - All equipment used in the maintenance, repair or inspection work shall be removed.
- Warning signs, barriers and guards shall be removed only by authorized personnel.
- Lock and tag on the main switch (disconnect) of the hoist, crane or lifting device shall be removed only by the person that locked and tagged the main switch originally, or an authorized person.

6.1.1 Inspection Records

Dated inspection reports and records of the condition of critical components such as load chain, hooks and brakes observed during frequent and periodic inspections should be established. This record should also record replacement, maintenance and repair information. Use of this recorded information will allow a preventative maintenance program to be established for replacement of wearing components on a regular basis, thereby eliminating or reducing unscheduled downtime situations. These records should be stored where they are available to personnel involved with the inspection, maintenance, or operation of the hoist.

6.2 Inspection Classification

Many factors influence the inspection and preventative maintenance programs required for the hoist. Frequency and severity of service and material handled, local environmental conditions and various applicable codes are some of the factors that the user must consider and adjust the inspection and maintenance programs outlined in this section to meet the specific conditions.

Inspection procedure for hoists in regular service is divided into two general classifications as outlined in ASME B30.16. These two general classifications are based upon the intervals at which the inspections should be performed. The intervals are dependent upon the nature of the critical components of the hoist and the degree of exposure the hoist components and parts to wear and deterioration. The degree of exposure is dependent upon hoist activity and severity of hoist service. Environmental conditions in which the hoist operates are also important considerations for the user when adjusting hoist inspection and maintenance programs to local conditions. Frequency of inspection and maintenance

must be increased if hoist is subjected to severe atmospheric environmental conditions, such as corrosive vapors, extreme heat or cold, cement or dust and other airborne contaminants. The user should carefully consider all environmental conditions and adjust frequency and degree of maintenance for his/her local conditions. Various codes also regulate inspection and maintenance programs. Attention must be given to applicable federal standards, OSHA regulations, national standards, state and local codes which may include mandatory rules relating to hoist inspection and maintenance. The user should become familiar with all applicable codes for his area and be guided accordingly.

These two general classifications of hoist inspections are designated as frequent and periodic. In addition, daily inspections are required to be performed by the operator at the start of each shift or at the time the hoist is first used during each shift.

FREQUENT INSPECTION: Frequent inspections are visual inspections and examinations by the operator or other designated personnel with records not required. Nominal inspection intervals are as follows:

- **Normal service** – monthly
- **Heavy service** – weekly to monthly
- **Severe service** – daily to weekly

PERIODIC INSPECTION: Periodic inspections are visual and audio inspections by designated personnel making records of external conditions to provide the basis for a continuing evaluation of the hoist and its components. If the external inspection indicates the need, some disassembly may be required to make a more detailed inspection and examination. Nominal inspection intervals are as follows:

- **Normal service** – annually
- **Heavy service** – semiannually
- **Severe service** – quarterly

The inspection and maintenance intervals outlined in this section are considered a minimum. The recommended minimum inspection and maintenance intervals are based on average daily use in a normal environment.

Perform these inspections regularly as scheduled and additional inspections as may be required for activity, service and environment of the hoist. The hoist operator must be responsible for determining the operating conditions and severity of service.



The inspection intervals listed above are nominal recommendations for reference purposes only. They are based on single shift operation under normal operating conditions and normal environmental conditions. Actual operating and environmental conditions should be reviewed by a qualified person and inspection intervals established on the recommendations of the qualified person.

6.3 Daily, Frequent & Periodic Inspections

Required daily inspection items to be performed by the operator at the start of each shift, or before the hoist is first used during each shift are shown in Table 6.3.1.

WARNING

If any damage or malfunctions are noted by the daily inspection items of Table 6.3.1, the operator shall not operate the hoist and shall immediately advise the supervisor so corrective action may be taken. If the hoist is tagged with an out of order sign, the operator shall not operate the hoist.

Hoist operators should be trained to be aware of malfunctions of the equipment during operation, and to immediately stop operation if such malfunctions occur and to immediately advise the supervisor so corrective action may be taken.

Recommended items to be checked for deficiencies or damage during frequent and periodic inspections are shown in Table 6.3.1. Detailed inspection procedures for some items will be found in specific sections of this manual. These inspections may be performed with the hoist in its normal location and do not require that the hoist be disassembled. Covers and other items normally supplied to allow inspection of components should be opened or removed for these inspections. Any deficiencies or damage such as those listed in Table 6.3.1 shall be examined by a designated person to determine whether they constitute a hazard, or whether any disassembly is necessary for a more detailed examination. The hoist operator should make observations during regular operation for any deficiencies or damage that might appear between inspections.

The list of items in Table 6.3.1 is based on those listed in ANSI/ASME B30.16 for the Frequent and Periodic Inspection. In accordance with ANSI/ASME B30.16, these inspections are not intended to involve disassembly of the hoist. Rather, disassembly for further inspection would be required if frequent or periodic inspection results indicated to do so. A qualified person, trained in the disassembly and re-assembly of the hoist, should only perform such disassembly and further inspection.

Table 6.3.1

Item	Daily	Frequent	Periodic	Inspection Points	Action
Tagged Hoist/Trolley	✓	✓	✓	Check that the hoist/trolley is not tagged with an out of order sign.	Do not operate hoist until an authorized person has repaired and cleared the hoist for operation.
Control Devices	✓	✓	✓	Check that the travel motions match with the control device markings. When checking hoist travel motion, always use the lifting/UP control first.	Repair or replace as required.
Upper Limit Switch	✓	✓	✓	Check that the upper limit switch stops the lifting motion of the hoist load block before striking any part of the hoist or crane.	Repair or replace as required.
Lower Limit Switch	✓	✓	✓	Check that the lower limit switch stops the lowering motion of the hoist hook with a minimum of 9 links of load chain on the unloaded side of the hoist.	Repair or replace as required.
Hook	✓	✓	✓	Check for damage, cracks, nicks, gouges, deformation of the throat opening, wear on saddle or load bearing point and twist.	Replace.
Hook Latch	✓	✓	✓	Check that the hook latch is not missing and that it operates properly.	Replace.
Load Chain	✓	✓	✓	Check for nicks, gouges and any type of deformation or damage to the load chain. Check for lubrication of the load chain.	Lubricate or replace.
Brake Mechanism	✓	✓	✓	Check that the hoist and trolley motions do not have excessive drift or slippage.	Adjust, repair or replace as required.
Oil Leakage	✓	✓	✓	Check for any sign of oil leakage on the hoist and on the floor area beneath the hoist.	Repair or replace as required.
Unusual Sounds	✓	✓	✓	Listen for any unusual sounds from the hoist and hoist mechanism while operating the hoist.	Adjust, repair or replace as required.

Reeving/Parting	✓	✓	✓	Check that the load chain is properly seated in the reeving/parting and that the load chain and associated parts are not twisted around each other.	Replace.
Capacity & Warning Label	✓	✓	✓	Check that the capacity, warning and other safety labels are not missing and are legible.	Replace.
Control Device Markings	✓	✓	✓	Check that the control device markings are not missing and legible.	Replace.
Fastening Devices		✓	✓	Check that the fastening devices are properly secured (tightened) and that there are no damage or missing parts.	Tighten or replace as required.
Sheaves		✓	✓	Check for cracks, damage to pockets and excessive wear.	Replace.
Load Block		✓	✓	Check for cracks, damage and distortion.	Replace.
Lubricant Levels			✓	Check the quality and quantity of lubricant levels.	Lubricate or replace.
Trolley Wheels			✓	Check for flat spots and excessive wear.	Replace.
Supporting Structure & Trolley			✓	Check for cracks, damage and distortion.	Repair or replace as required.
Electrical Apparatus			✓	Check for pitting, deterioration, wear and improper operation.	Repair or replace as required.
Wiring & Fittings			✓	Check for loose connections and abraded, cut or nicked insulation and wires.	Tighten, repair or replace as required.

6.4 Hook Inspection

Load hooks on hoists in regular service should be visually inspected daily by the operator. If the hoist is used in multiple shift operations, load hooks should be visually inspected by the operator at the start of each shift or before being used for the first time on each shift. When a visual inspection indicates that a more detailed inspection is required, follow the procedures outlined below. These procedures also apply to scheduled frequent and periodic inspections. Refer to Table 6.4.1 for Hook original dimensions.

- Measure hook throat opening from metal to metal of the hook as shown by dimension “g” in Figure 6.4.1. **DO NOT** measure from latch to metal. Hook must be replaced when throat opening measurement has increased 5% over the original throat opening dimension of a new hook. Refer to Table 6.4.2 for original dimensions and replacement dimensions for throat openings of standard hooks specified for the ACI electric chain hoist line. To aid in measuring the throat opening, it is recommended the hoist owner/user make a gage of the dimensions shown in Table 6.4.2. This will allow quick measurement of the throat opening and immediate indication that the hook replacement is required.
 - If the electric chain hoists are specified with special hooks not covered in Table 6.4.1, the hook throat opening should be measured by the owner/user prior to installing the hoist. This will establish a reference point to use in future inspections for determining when the throat opening dimensions have increased by 5% thus requiring the hook be replaced. A gage similar to the one discussed above is recommended. The gage should have the throat opening dimension measured prior to installation, and a dimension 5% greater than the throat opening dimension measured prior to installation.
- Measure Hook depth at the load bearing point (base, bowl or saddle) of the hook as shown by dimension “c” in Figure 6.4.1. The hook must be replaced when wear at load bearing point has decreased the original depth of the hook load bearing point by 5%. Refer to Table 6.4.2 for original dimensions and replacement dimensions for depth at load bearing point of standard hooks specified for the ACI electric chain hoist line.
 - If the electric chain hoists are specified with special hooks not covered in Table 6.4.1, the hook depth at the load bearing point should be measured by the owner/user prior to installing the hoist. This will establish a reference point to use in future inspections for determining when the wear at the load bearing point has decreased the original depth by 5%, thus requiring hook replacement.

Figure 6.4.1
Hook Dimension Reference

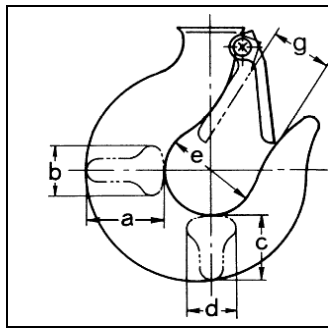

Table 6.4.1
Hook Dimensions

Capacity*		a*	b*	c*	d*	e*	g*
0.25	0.5	1.02	0.75	1.02	0.75	1.3	1.1
1		1.34	0.94	1.3	0.94	1.65	1.18
2		1.81	1.22	1.69	1.18	1.93	1.57
3		2.2	1.42	1.97	1.42	2.32	1.89
5		2.64	1.61	2.24	1.61	2.36	1.89
7.5		3.43	2.36	3.31	2.36	3.35	2.76

*Capacity in tons & measurements in inches

Figure 6.4.1
Hook Dimension Reference

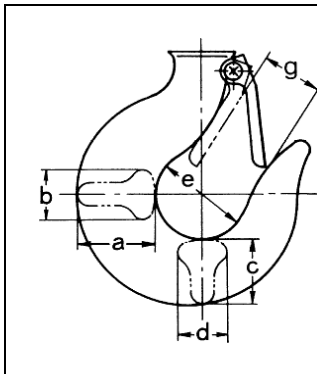

Table 6.4.2
Hook Throat Opening and Hook Depth Dimensions

Capacity*		Dimension g*		Dimension c*	
		New Hook	Replace Hook	New Hook	Replace Hook
0.25	0.5	1.1	1.16	1.02	1.07
1		1.18	1.24	1.3	1.36
2		1.57	1.65	1.69	1.78
3		1.89	1.98	1.97	2.07
5		1.89	1.98	2.24	2.36
7.5		2.76	2.89	3.31	3.47

*Capacity in tons & measurements in inches

- A bend or twist exceeding 10° from the plane of the unbent hook requires the replacement of the hook.
- A hook latch, when required, that is missing shall be replaced
- A hook latch, when required, that is inoperative shall be repaired or replaced.
- Hooks having damage from chemicals, corrosion or deformation shall be repaired or replaced. Damage in the form of cracks, nicks and gouges may be repaired by a designated person by grinding longitudinally, following the contour of the hook, providing no dimension of the hook is reduced by more than 5% of the original dimension of a new hook. If the repair reduces the dimension of the hook by more than 5% of the original dimension of a new hook, the hook shall be replaced.

NOTICE

Any hook that requires replacement because of excessive bends, twists or throat opening indicates abuse or overloading of the hoist therefore, other load supporting components of the hoist should be inspected for possible damage when such conditions are found.

⚠ CAUTION

Never repair hooks by welding or reshaping. Heat applied to the hook will alter the original heat treatment of the hook material and reduce the strength of the hook.

⚠ CAUTION

Never weld handles or other attachments to the hook. Heat applied to the hook will alter the original heat treatment of the hook material and reduce the strength of the hook; if handles or other attachments are required on the hook, contact ACI or the distributor of the hoist.

⚠ CAUTION

DO NOT use cotter pins, groove pins or locknuts that have been removed during disassembly. They may be damaged during removal and will not function properly if reused. Always install hook nuts using new cotter pins.

6.5 Limit Switch Inspection

ACI hoists are equipped with a rocker type limit switch (see Figure 6.5.1), which are operated by the limit lever and actuator attached to the chain in the raising direction, and an actuator and stopper attached to the chain in the lowering direction. The chain operated limit stop is provided to guard against over travel of the load in either raising or lowering directions, which can cause damage to the hoist.

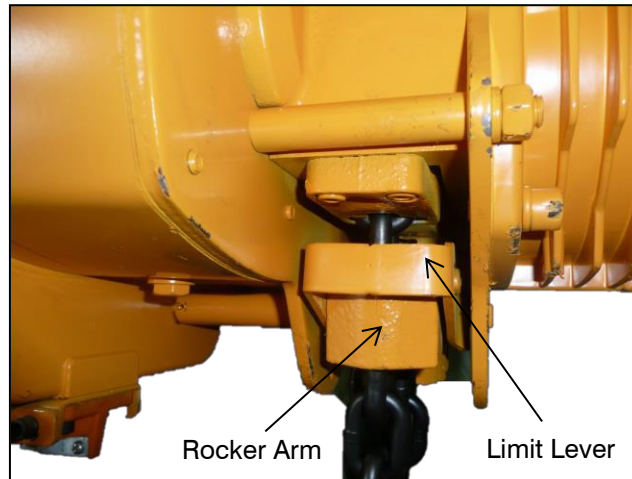

Figure 6.5.1

When the highest position is reached the limit actuator (limit spring) on the load chain, above the hook block, trips the limit lever (see Figure 6.5.2).

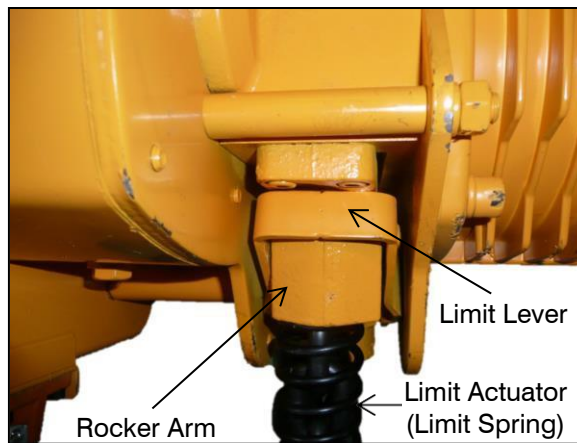

Figure 6.5.2

When the lowest position is reached the limit actuator on the tail end of the load chain trips the limit lever (see Figure 6.5.3).

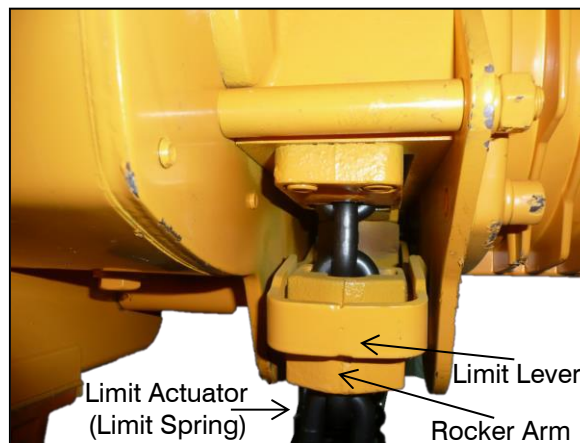

Figure 6.5.3

The limit lever is connected to a limit switch that automatically stops the hoist motor. This is intended as a safety device and is not to be used on a routine basis to stop travel of hook block or to shut off the hoist.

The hoist lower limit device is set at the factory to stop lower travel of the load block with approximately 10 to 15 links of load chain extending beyond the chain guide on the unloaded side of the hoist. It is recommended that the lower limit device be set to prevent the load block from resting on the floor and allowing the load chain to go slack.

The hoist upper limit device is set at the factory to stop hook travel when the load block is approximately 3 inches below the hoist or hoist frame. By changing chain stop location, the limit switch setting can be adjusted. To do this, loosen the two screws holding the chain stopper until the stopper can be released from the chain (see Figure 6.5.4).

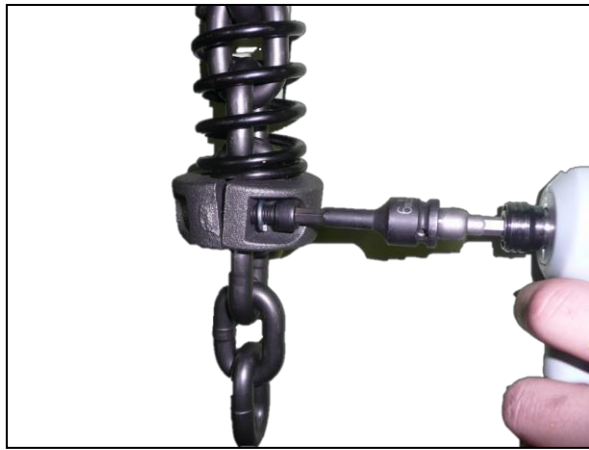

Figure 6.5.4

Install the stopper as follow:

- In some hoist models even when the chain container is used, the free end of the chain is attached to the hoist body as shown in Figure 6.5.5. Depending on the hoist size and capacity, install the chain stopper approximately 7 to 12 links from the free end and make sure the chain remains free of twists.

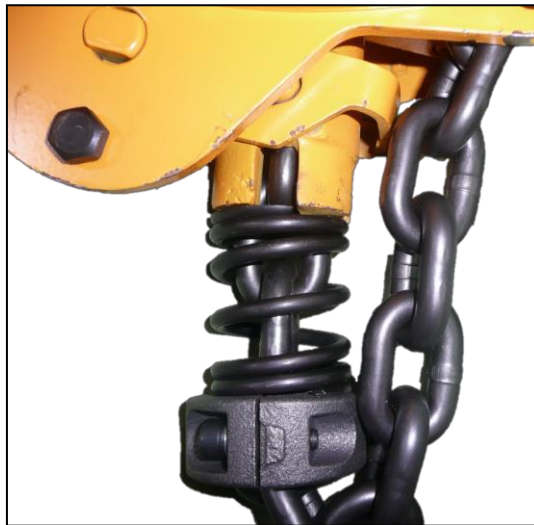

Figure 6.5.5

- In some other hoist models, the free end of the chain is not attached to the hoist body and the chain stopper is installed on the third link from the free end as shown in Figure 6.5.6.



Figure 6.5.6

6.6 Load Chain Inspection

Load chain on hoists in regular service should be visually inspected daily by the operator. If the hoist is used in multiple shift operations, the load chain should be visually inspected by the operator at the start of each shift or before the first time it is operated on that shift. The daily inspection by the operator is for visual damage to the load chain. Such damage includes nicks, gouges, cracks, wear, twists, kinks, stretch, distortion or deformation, end connections, deposits of foreign material, heat damage and inadequate lubrication. Inspections should also include visual damage to load chain end connections including damaged, worn, loose, or missing end connections. When visual damage is present, the operator shall report such damage to the supervisor and shall not operate the hoist until a more detailed inspection is performed to determine that the chain can be used or the chain is replaced. Detailed inspection procedures are outlined below. These procedures also apply to scheduled frequent and periodic inspections.

⚠ WARNING

DO NOT operate a hoist with a chain that shows any sign of damage, deformation, excessive stretch or excessive wear.

The load chain should be inspected during scheduled frequent and periodic inspections; or if the daily visual inspection by the operator indicates a more detailed inspection is required, as follows:

1. Test the hoist with a load on the hook in both lifting and lowering directions. The load chain should feed smoothly into and away from the sheaves or sprockets.
2. If the load chain binds up, jumps or is noisy, check that the load chain is clean and properly lubricated. If the load chain still binds up, jumps or is noisy, clean the load chain and inspect the chain and mating parts for wear, stretch, distortion and other damage.
3. Check the load chain visually for gouges, nicks, weld splatter, corrosion, and twisted or distorted links. The existence of any of these conditions is sufficient reason to question continued use of the chain and therefore the chain should be replaced.

- Check load chain for wear at the inter-link contact points. Slacken the chain and move adjacent links apart to one side to observe and inspect for wear at the contact points. If wear is observed, measure the diameter of the chain link at the wear contact point. Case hardness of chain is about 0.015" deep. Chain must be replaced before the case is worn through. Also check chain for elongation using a Vernier caliper (see Figure 6.6.1).

⚠ WARNING

Do not assume that the load chain is safe because it measures below replacement points given herein. Other factors, such as those mentioned in visual checks above may render the chain unsafe or ready for replacement long before elongation replacement is necessary.

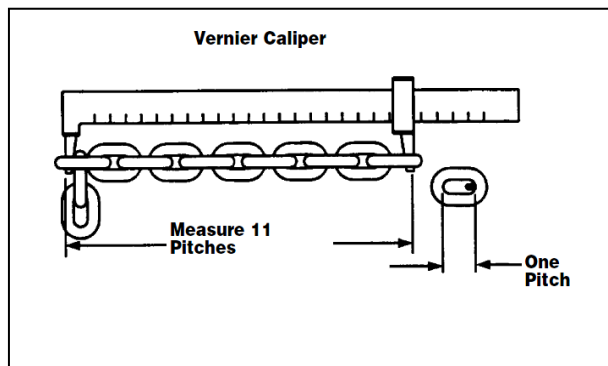

Figure 6.6.1

- Select an unworn, un-stretched section of chain (usually at slack or tail end) and measure and record the length over the number of chain links (pitches) indicated in figure 6.6.1. Measure and record the same length of a worn section in the load side of the chain. Obtain the amount of wear by subtracting the measurement of the unworn section from the measurement of the worn section. If the result (amount of wear) is greater than the amount specified in the "Allowable Chain Wear" (Table 6.6.1) then the chain has elongated beyond the maximum allowable length and must be replaced.

Table 6.6.1
Allowable Chain Wear

Hoist Capacity*				Number of Pitches to Measure	Max Wear Limit**
0.25		0.5		11	0.138
1	2	3		11	0.138
2		3		11	0.196
3	5	7.5	10	11	0.221
15	20	25	30		

- Replace chain with excessively pitted, corroded, nicked, gouged, twisted or worn links using only factory approved chain. Replacement load chain must be the same size, grade and construction as the original chain. Never weld or attempt to repair the chain.
- When the chain is replaced, disassemble the mating parts, such as sheaves, sprockets, guides and stripper for wear and replace as required.

8. Parting of replacement chain must be the same as the original parting of chain on the hoist. Refer to Figure 6.6.2 for parting arrangement of hoists.
9. Replacement chain must be installed without any twist between the hoist and an anchored end on either the loaded or slack (unloaded) side of the driving sheave.

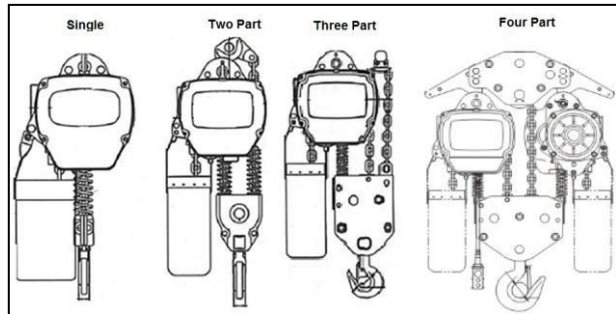

Figure 6.6.2

⚠ WARNING

DO NOT operate a hoist with a twist in the load chain. Operating a hoist with a twist in the load chain can cause the load chain to break and result in serious bodily injury or death and/or property damage.

10. To check the load chain for twists, raise the load block without a load to within three feet of driving load sheave. Check the links. Welds must be away from the driving load sheave grooves and toward the load block sheave grooves.
11. Do not use hoist until replacement load chain has been lubricated. Refer to the lubrication section of this manual.

6.7 Hoist Motor Brake Inspection

The hoist braking system on hoists in regular service should be checked without load on the hook by the operator at the start of each shift, or before the first time the hoist is to be operated during each shift. The hoist braking system should be checked during scheduled frequent and periodic inspection.

During daily, frequent or periodic inspections, the hoist braking system should be checked by operating the hoist in the lifting and lowering directions, without a load on the hook, and stop the hook motion to check operation of the hoist braking system. The hook's drift should not exceed ¼ inch in either direction. If the hook drifts exceeds 1.4 inch, the motor brake requires adjustment or the lining requires replacement. Refer to section 7.4 Hoist Motor Brake Adjustment for further details.

The brake lining is designed for a long life and should provide years of trouble free service. If the brake lining is being inspected due to excessive load chain drift during operation, disassemble the motor brake and inspect all motor brake parts. Braking surfaces should be clean, free of grease/oil and should not be glazed. Replace the brake pad assembly and/or motor cover if necessary. For normal inspections, the brake lining should be measured and the motor cover wear should be inspected. Compare the measurement with the values listed in Table 6.7.1. Replace the brake pad assembly if the measurement is smaller than the replacement limit. Refer to section 7.5 Hoist Motor Brake Disassembly.

Table 6.7.1

HP	Brake Disc Thickness	
	Nominal	Replace
1	0.177	0.159
2	0.177	0.159
3	0.217	0.195

6.8 Trolley Inspection

Trolleys specified for the ACI electric chain hoist line include:

- Push under-running trolleys
- Hand-gearred under-running trolleys
- Motor-driven under-running trolleys

The trolley should be inspected every three months and during scheduled frequent and periodic inspections as follows:

1. Inspect trolley wheel bearings for wear by manually rotating and rocking wheels. If excessive bearing play is present, replace bearings.
2. Inspect for wear, flat spots or damage to wheel tread and cracked or broken wheel flanges. Replace wheels as required. When wheel replacement is required, all the wheels of a trolley should be replaced.
3. Inspect gear teeth of geared wheels and pinion for wear, cracks or damage. Replace geared wheels or pinion as required. Geared wheels should always be replaced in pairs.
4. Inspect and tighten or replace as required, all bolts, nuts and locking devices.
5. Check lubrication in accordance with the Lubrication section of this manual.

The Trolley brake (if specified) on hoists in regular service should be checked without a load on the hook by the operator. At the start of each shift or the first time the hoist is to be operated during each shift. The trolley brake should be checked during scheduled frequent and periodic inspections.

During daily, frequent or periodic inspections, the trolley brake should be inspected as follows:

- Operate the trolley in both travel directions, without a load on the hook, and stop the motion to check operation of the trolley brake. The drift of the trolley should not exceed a distance equal to 10% of the trolley's travel speed in either direction. If trolley drift exceeds this distance, the motor brake normally requires lining replacement.
- After completing trolley brake lining replacement, operate trolley in both travel directions, without a load on the hook, and stop motion to check operation of the trolley brake. If the trolley drift is still excessive, replace the brake assembly.

The brake lining is designed for a long life and should provide years of trouble-free service. If the brake lining is being inspected due to excessive trolley drift during operation, disassemble the motor brake and inspect all motor brake parts.

Brake surfaces should be clean, free of grease/oil and should not be glazed. Replace the brake assembly and/or motor cover if necessary. Inspection of the motor brake requires removal of the motor brake unit from the trolley as an assembly. Refer to the Electric Trolley Assembly Drawing, Figure 10.5.1, remove the motor brake as follows:

- Loosen and remove the four screws and spring washers that attach the motor brake end cover to the motor frame.
- Remove the motor cover, brake components and stator (see Figure 6.8.1).



Figure 6.8.1

- Use brake cleaner to remove any lining dust that has accumulated on brake parts (see Figure 6.8.2).

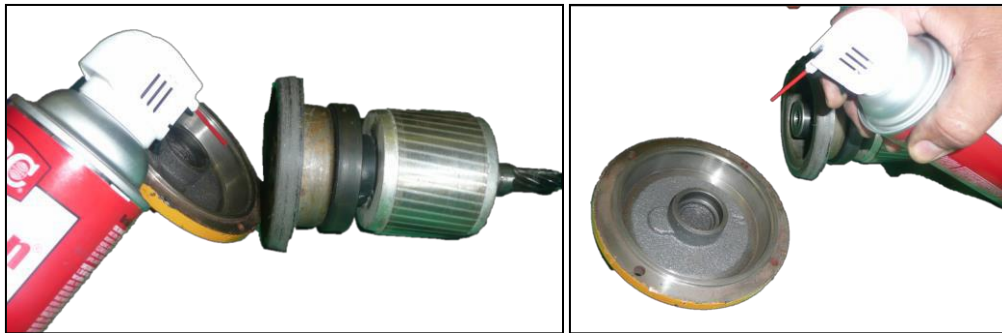

Figure 6.8.2

- Check for loose electrical connections or broken wires. Repair or replace as required.
- Check thickness of brake pad. Replace the brake pad if worn to a thickness of 0.14 inch (3.6 mm) or less.
- Trolley brake is not adjustable.
- After the brake is inspected, carefully place the stator and brake components into the motor frame. Be sure to put back the gasket. Install the motor cover attachment screws.

⚠ DANGER

Disconnect power and lockout disconnecting means before adjusting trolley motor brake.

Only qualified personnel should adjust brakes.

6.9 Tests

All new complete hoists, less trolley or trolleys, are load tested by ACI in accordance with ASME B30.16. Hoists furnished in an uncompleted condition (example, less controls, less motor, less load chain, etc.) as hoist components, and winch units are not load tested by ACI. Therefore, it is the responsibility of the owner/user to load test the final lifting system, using such hoist components or winches in accordance with ASME B30.16. If the hoist is installed on a crane, load testing of the crane in accordance with, as applicable, ASME 830.2, ASME B30.11, or ASME B30.17 may be required.

Testing of hoists after original installation is required when the hoist has been altered or repaired; has been idle for a period 12 months or longer; or in accordance with specific testing requirements established by the owner/user. General testing requirements are outlined in ASME 830.16 and should be followed. ASME B30.16 lists two types of hoist tests as follows:

- Operational Test
- Load Test

ASME B30.16 uses the words **SHALL** and **SHOULD** in listing requirements and defines these two words as follows:

- **SHALL** – indicates that the rule is mandatory and must be followed.
- **SHOULD** – indicates that the rule is a recommendation, the advisability of which depends on the facts in each situation.

6.9.2 Operational Test

All altered or repaired hoists, or hoists that have not been used within the past 12 months, **SHALL** be tested by the owner/user before being placed in operational service. The operational test is performed without a load on the hook and includes:

- Operation of control devices.
- Lifting and lowering.
- Operation of brakes.
- Operation and setting of limit switch devices.

Operational test procedures are as follows:

- i. Check hoist travel for correct hook motion to ensure the hoist motor is properly phased. Since motor rotation of a three-phase AC motor can be changed by reversing any two of the lines feeding power to the motor, the direction of hook motion must be checked to verify that it is correct in accordance with the hoist control device markings.
 - **MOMENTARILY** activate the **UP** button of the hoist control device and observe the direction of hook motion. If the direction of the hook travel matches with the direction marking of the hoist control device button activated (example, hook direction is UP when the hoist UP control device button is activated), the hoist motor is properly phased and proceed to step 2. If the direction of the hook travel does not match with the direction marking of the hoist control device button activated, the hoist motor is improperly phased and must be corrected. **DO NOT** use the hoist until motor phasing is corrected.

WARNING

DO NOT attempt to correct an improperly phased hoist by changing the wiring in the hoist control device or the hoist contactors; or by changing the markings on the hoist control device.

Utilize the following steps to correct hoist motor phasing:

DANGER

1. Disconnect the power, lockout and tagout the power supply before working on the electrical wiring to prevent accidental application of power.
2. Only a qualified person should disconnect or connect the power lines to the hoist.

3. Interchange any two lines supplying power to the hoist.
4. Re-energize power supply to the hoist.
5. Check the hoist travel direction for correct hook motion by pressing **UP** on the hoist control device. If the direction of the hook travel matches the direction marking of the hoist control device button activated then the hoist motor is properly phased. If the direction of the hook travel does not match the direction marking of the hoist control device button activated the hoist motor is improperly phased and must be corrected by repeating steps 1 through 5.
 - ii. If the hoist has a motorized trolley, check that the trolley travel motion matches the direction marking of the trolley control device button activate.
 - **MOMENTARILY** activate one button of the trolley control device and observe the direction of trolley motion. If the direction of the trolley travel matches the direction marking of the trolley control device button activated (example, the trolley direction is EAST when the trolley EAST control device button is activated), the trolley motor is properly phased. If the direction of the trolley travel does not match with the direction marking of the trolley control device button activated, the trolley motor is improperly phased and must be corrected. **DO NOT** use the trolley until motor phasing is corrected.

WARNING

DO NOT operate the trolley if direction of the trolley motion does not match the direction marking on the trolley control device button activated.

WARNING

DO NOT attempt to correct an improperly phased trolley by changing any wiring to the trolley control device or at the trolley contactors; or by changing the markings on the trolley control device.

Utilize the following steps to correct trolley motor phasing:



1. Disconnect the power supply, lockout and tagout the disconnecting means before reconnecting (reversing) power lines to trolley.
2. Only a qualified person should reconnect the power lines to the trolley.

3. Interchange any two lines supplying power to the trolley motor only. **DO NOT** reverse main power leads to the hoist as this will also affect the phasing of the hoist motor.
4. Re-energize the power supply to the hoist.
5. Re-check the trolley travel for correct trolley motion. If the direction of the trolley travel matches the direction marking of the trolley control device button activated (example, the trolley travel direction is EAST when the trolley EAST control device button is activated), the trolley motor is properly phased. If the direction of the trolley travel does not match with the direction marking of the trolley control device button activated, then the trolley motor is improperly phased and must be corrected by repeating steps 1 through 5.
 - iii. Operate hoist in the raising and lowering directions, without a load on the hook, and stop motion to check operation of the motor brake. The hook drift should not exceed $\frac{1}{4}$ inch in either direction. If the hook drift exceeds $\frac{1}{4}$ inch, the motor brake requires adjustment. Refer to the motor brake section of this manual for instructions on motor brake adjustment.

6.9.3 Load Test

All hoists in which load suspension parts have been altered, replaced or repaired **SHALL** be dynamically tested by the owner/user before being placed in operational service. The load test shall be conducted under the direction of a designated person and a record of the test should be made. The test load applied to the hoist shall be at least equal to the rated load capacity of the hoist, or greater as approved by the hoist manufacturer. Functions to be performed during the load test include:

- Operation of control devices.
- Lifting and lowering.
- Operation of brakes.

Load test procedures are as follows:

1. Attach the test load to the hoist hook. The test load **SHALL** be at least equal to the rated load capacity of the hoist. ACI will authorize the use of a hoist test load equal to 125% of the rated load capacity of the hoist for load test purposes only.
2. Before lifting the load, operate the hoist in the lifting direction to take any slack out of the hoist load chain.
3. Lift the load a few inches and stop the hoist. If brakes stop and hold the load, continue lifting and lowering the load several feet, stopping the hoist several times in each direction to check that the hoist braking system stops and holds the load.
4. If the hoist braking system stops and holds the load, the hoist operates in accordance with the control devices and no unusual sounds are present during operation, the hoist is ready to be released for operating purposes.
5. If the hoist braking system does not stop and hold the load, the hoist does not operate in accordance with the control devices or any unusual sounds are present during operation, the hoist is not ready to be released for operating purposes; and corrective action must be taken.

7.0 MAINTENANCE & REPAIR

Repairs include removal of small defects noticed during inspections, such as, damage of the cables or light activities as replacement of the contactors and relays. They do not include technical activities that must be coordinated with the manufacturer, such as, changing the electric diagram or implementation of additional devices.

If maintenance, adjustment, replacement of parts or repair of the hoist is required due to any damage or malfunctions noted during the daily, frequent or periodic inspections outlined in the Inspection section of this manual; due to conditions found during a hoist test as outlined in the Test section of the manual; or based upon specific instructions outlined in other sections of this manual, the hoist shall be taken out of service and maintenance performed as required.

Follow the instructions outlined in various sections of this manual for specific components or portions of the hoist where maintenance or adjustment is required. Refer to the parts identification pages for the specific portion of the hoist where maintenance or adjustment is being performed and to identify and part numbers requiring replacement. If any instructions are unclear; or if any additional information is required in reference to adjustment, maintenance or identification of parts; contact ACI Hoist & Crane or the distributor of the hoist.

7.1 Lubrication

All moving parts of the hoist or trolley for which lubrication is specified should be inspected, checked and lubricated on a regular basis. This section applies to the hoist and trolley only. If the hoist is installed as part of a crane or as part of a lifting system, lubrication instructions covered in the manual furnished by the crane or lifting system manufacturer should be followed.

Hoist and trolley drive unit gear are enclosed and provided a liberal oil reservoir from which gears and bearing inside the hoist are splash lubricated. Check oil level in gear housing periodically with intervals determined by use and operating conditions.

Hoist and trolley machinery must be stationary when inspecting, checking, adding or changing lubricants. The main switch (disconnected) of the hoist, crane or lifting system must be de-energized. Lock and tag the main switch in the de-energized position in accordance with ANSI Z244.1.

7.1.1 Hoist Gear Housing

The gear housing cover contains the oil fill hole and eye bolt, check the hole (oil level hole) and plug, as well as the oil drain hole and plug as shown in Figure 7.1.1.1

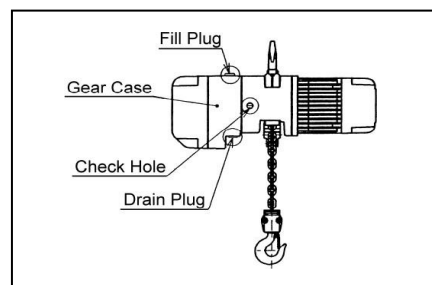

Figure 7.1.1.1

- Check the oil level in the oil level hole. The level of the oil in the housing should be level with the bottom of the oil level hole. If the level of the oil in the housing is below this point, add oil. Add oil through the oil fill hole until oil level in the housing is level with the bottom of the oil level hole.



Figure 7.1.1.2

- When the hoist is shipped from the factory, the oil fill hole is closed by use of an eye bolt in the upper side of the gearbox casing (see Figure 7.1.1.3). **DO NOT** fill above oil level hole, as this will cause oil leakage.



Figure 7.1.1.4

- Removal of oil from the housing is done through the drain hole. The oil drain plug is the bolt in the underside of the gearbox casing. Replace the drain plug and refill the gear case with new oil through the oil fill hole until oil level in the housing is level with the bottom of the oil level hole.
- For normal service, check the hoist gear housing gear oil after 500 operational hours. Thereafter, check oil level every 3 months. Replace the oil more frequently for heavy service or as required by operating environment.
- The hoist is shipped from the factory with the correct quantity and type of oil in separate container(s), or use of engine oil with the same grade of ISO VG 46 or equivalent is authorized. For hoist gear box oil capacity refer to Table 7.1.1.1.

Table 7.1.1.1
Gear Box Oil Capacity

Hoist Capacity (Tons)						Gear Box Oil Capacity (Liters)
0.25	0.5		1			0.8
2	3	5		7.5		1.5
10	15	20	25	30	35	3

7.1.2 Hook Thrust Bearing

For normal service, clean and apply light machine oil to the thrust bearing that supports the load hook at least once per year. Apply oil more frequently for heavy service or as operating conditions require.

7.1.3 Chain Lubrication

A small amount of lubricant will greatly increase load chain life, therefore, the chain should not be allowed to run without lubricant. Before using the hoist, clean the load chain with an acid free solvent to remove any accumulation of dirt or grit. Then lubricate thoroughly using any Chain LU Lubricant such as “Moly Chain Lubricant, LU 202” or equivalent. Make

sure inter-bearing surfaces of links are well coated. Also apply the grease to the areas of the load chain that contact the load sheave (see Figure 7.1.3.1). Ensure that the grease is applied to the contact areas in the load sheave pockets.

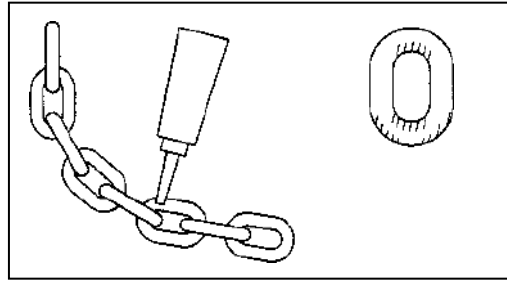

Figure 7.1.3.1

NEVER allow load chain to become dry. Lubricate every 3 months or after observing operating conditions for a few days and setup a regular schedule for chain lubrication.

Frequency of lubrication depends upon use and environment. If necessary lubricate more often and frequently for heavier usage or severe conditions.

ALWAYS clean the load chain before lubrication.

7.2 Chain Maintenance

The load chain should be kept clean and free from any coating or deposits of foreign material which can cause buildup and change link dimensions or reduce the flexibility between chain links. The cleaning process utilized to clean the chain must not damage the chain; any solution used shall be acid-free.

Replacement chain should be stored in a manner to prevent damage or deterioration to the chain.

During installation of chain, care should be exercised to avoid dragging the chain in dirt or around objects that will scrape, nick, cut, crush or induce sharp bends in the chain.

Load chain links articulate slowly under high bearing pressures. The load chain must be lubricated, refer to the Lubrication section of this manual.

7.3 Chain Replacement

Instructions for replacing the load chain on the hoist are outlined below. Parting of replacement load chain must be the same as the original parting of load chain on the hoist. Refer to Figure 6.6.2 for parting arrangement of hoists and Figure 10.2.1 for Chain Assembly.

1. Follow the procedures and instructions listed in the Maintenance and Inspection sections of this manual.
2. Remove any load from the hoist hook.
3. Lower hoist hook until lower limit switch stops downward motion of hook.
4. If the hoist is equipped with a chain container, remove the chain container. Refer to Figure 4.2.4.3. If the hoist does not have a chain container, locate the chain support on the hoist body and remove the load chain.

! WARNING

DO NOT use cotter pins, groove pins or locknuts that have been removed during disassembly. They may be damaged during removal and will not function properly if reused. **ALWAYS** install load chain using new cotter pins, groove pins or locknuts.

5. Replacement load chain is installed by attaching it to the tail end of the old chain, after disconnecting the old chain from side of hoist frame and removing the limit actuator.
6. Use open “C” links for attaching the new chain to the old chain (see Figure 7.3.1). Links must be identical in size to hoist chain. Refer to Table 7.3.1 for “C Opening Cut Size”. The new chain is then run into the hoist as the old chain is run out. Be certain that all welds on the links of the replacement chain face away from the center of the load sprocket.

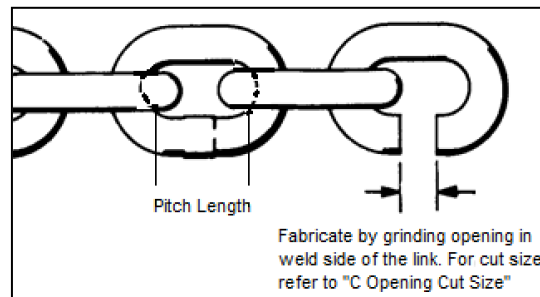

Figure 7.3.1

Table 7.3.1
“C” Opening Cut Size

Capacity*		Pitch Length**		“C” Opening Size**
0.25	0.5	0.75		9/32
1	2	0.83		5/16
1.5	2	1.18		7/16
2.5	3	5	7.5	15/32
*Capacity measured in tons.				
**All other measurements in inches.				

7. Remove the hook block assembly and actuator from the old chain and attach them to the replacement chain at the end which was just run through the hoist. Depending on hoist configuration, install limit actuator (chain spring and stopper) on the other end of the chain or connect the end chain to the hoist body.

NOTICE

To avoid serious internal damage to the hoist, when installing the load chain, **DO NOT** attempt to hand feed the chain into the hoist, or use a piece of wire in place of the method described herein. To do so may result in serious internal damage to hoist, as the chain links must be properly seated in the chain sprocket before chain is run into the hoist. Install the chain only as described in this manual.

8. If the hoist is equipped with a chain container, reinstall the container. Place the end of the new load chain with the stop into container.
9. Examine entire length of the new load chain for twists. Eliminate any twist that is found.
10. Test all the limit switches before returning the hoist to regular service.
11. Lubricate the new load chain. Refer to the Lubrication section of this manual.

7.4 Hoist Motor Brake Adjustment

To keep the hoist working in optimum condition and prevent possible downtime, it is recommended to check the motor brake lining and adjustment at regular intervals.

Inspection and adjustment of the motor brake requires removal of the motor brake unit from the hoist as an assembly. But first, be sure that the power is off, the hoist is unloaded and the load chain is secured.

⚠ DANGER

Before proceeding, disconnect the power supply and make sure the hoist is unloaded. To keep the load chain from moving, secure it by tying together the load and no-load sides directly under the hoist using a cord or wire.

Refer to Figure 10.1.1 for Motor and Body Parts List.

1. Loosen and remove socket head cap screw and spring washers securing the motor shell (see Figure 7.4.1).

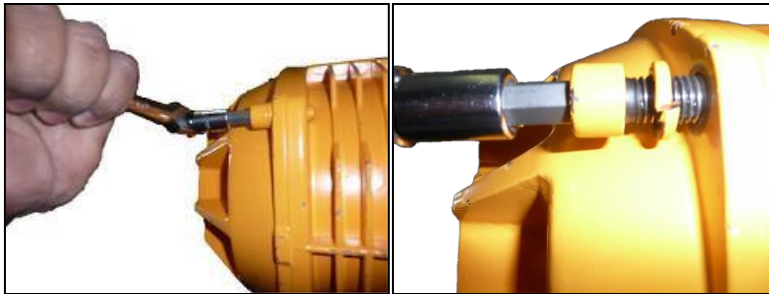

Figure 7.4.1

2. Carefully pull the motor brake unit out of the hoist (see Figure 7.4.2).

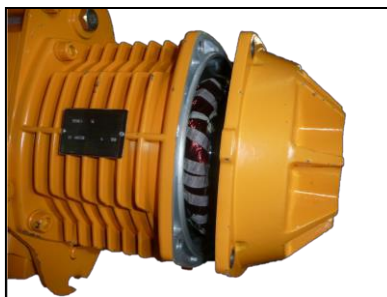

Figure 7.4.2

The brake gap is the gap between the brake pad assembly and the brake magnet coil (see Figure 7.4.3).

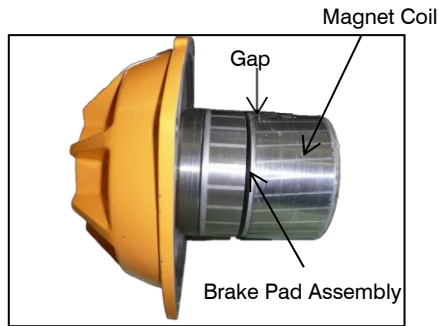

Figure 7.4.3

As the brake disc wears, this gap increases and the brake will not release, and the brake gap will require adjustment. The correct gap is 0.02". Adjustment should not be necessary until the gap is 0.031". Adjustment of the brake gap is accomplished by turning the adjustment nut in the center of the motor cover as follows:

1. Remove the rubber cover (see Figure 7.4.4).



Figure 7.4.4

2. Bend the tab of the lock washer away from the adjusting nut so that the adjusting nut can be rotated (see Figure 7.4.5).

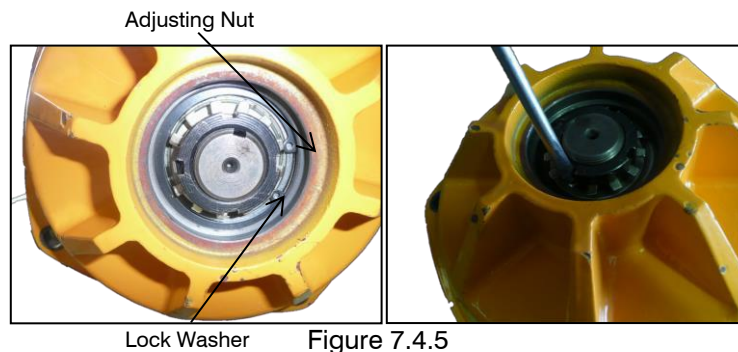

Figure 7.4.5

3. Use a brake adjusting tool to rotate the adjusting nut to attain the proper brake gap of 0.02" (see Figure 7.4.6).



Figure 7.4.6

4. Use a feeler gauge to measure the brake gap (see Figure 7.4.7).



Figure 7.4.7

5. After the brake gap is set, secure the adjusting nut by bending one of the tabs of the lock washer into a slot in the adjusting nut. If necessary rotate the adjusting nut clockwise (tightening) to line up the tab with the slot.
6. If the proper brake adjustment cannot be achieved, disassemble the motor brake and inspect all motor brake parts. Replace the brake pad if necessary.

7.5 Hoist Motor Brake Disassembly

1. Loosen and remove socket head cap screw and spring washers securing the motor shell (see Figure 7.4.1).
2. Carefully pull the motor brake unit out of the hoist (see Figure 7.4.2).
3. Remove the rubber cover (see Figure 7.4.4).
4. Bend the tab of the lock washer away from the adjusting nut so that the adjusting nut can be rotated (see Figure 7.4.5).
5. Remove the adjusting nut, lock washer and washer (see Figure 7.5.1).

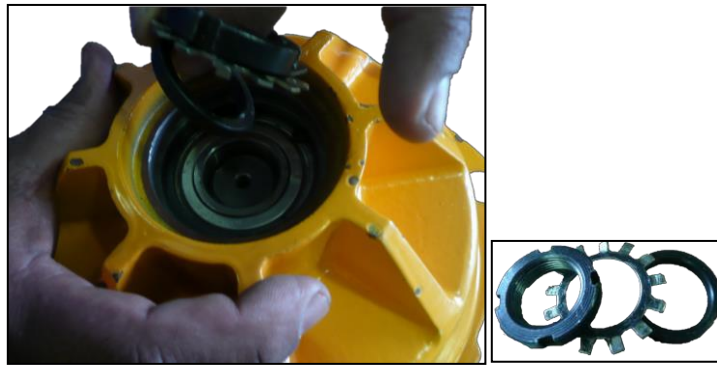
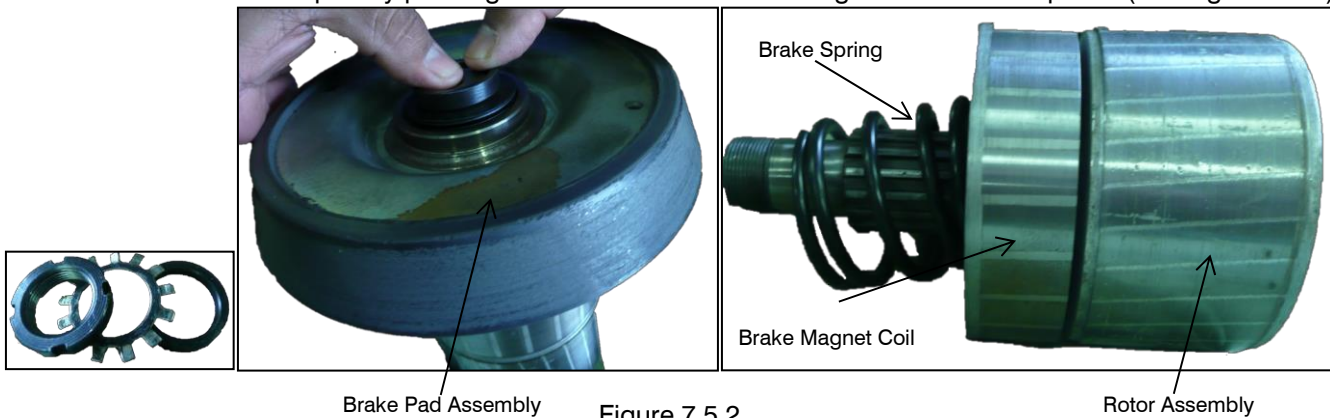

Figure 7.5.1

6. Remove the motor cover.
7. Release the brake pad by pushing the shaft down and removing the washer and plates (see Figure 7.5.2).



Brake Pad Assembly

Figure 7.5.2

Rotor Assembly

8. Inspect all parts. Braking surfaces should be clean, free of grease/oil and should not be glazed. Measure brake gap (see Figure 7.4.7) and brake lining (see Figure 7.5.3) and compare the measurement with the values listed in Table 6.7.1. Replace the brake pad assembly if the measurement is smaller than the replace limit.



Figure 7.5.3

9. After the brake is properly adjusted and inspected, carefully replace the motor brake unit back into the hoist. Reassemble the parts in reverse order of removal.

8.0 TROUBLESHOOTING

If the hoist operates erratically, or not at all the hoist should be taken out of service. Any problem should be diagnosed and corrected before the hoist is returned to regular service. Refer to Table 8.1 for some problem areas to consider and investigate.



Disconnect power and lockout/tagout the disconnecting means before performing service to electrical parts of this equipment.

Only a qualified person should perform service to electrical parts of this equipment.

Table 8.1
Troubleshooting Guide

Problem	Possible Cause	Corrective Action
Hoist will not operate.	Power failure in power lines.	Check circuit breakers, switches and connections in power lines. Check power collectors.
	Wrong voltage or frequency.	Check voltage and frequency, or power supply. Check voltage required on motor data plate against power supply.
	No control voltage.	Check transformer fuses. If blown, check for grounding and/or short in the pushbutton station. Check the transformer coil for signs of overheating. Replace transformer if burned out. Verify the transformer secondary is the same voltage as the coils to which it is connected.
	Motor overheated.	Check voltage and frequency, or power supply. They must match with the data on the nameplate.
	Improper, loose or broken wire connection	Check wiring connections. Check connections in pushbutton station and limit switches.
	Brake does not release.	Check connections and lead wires. Check connections in control devices.
	Control transformer damaged.	Check transformer fuses, coil and open winding.
	Motor burned out.	Replace the motor.
Hook moves in the wrong direction.	Reverse phasing.	Interchange any tow power supply line leads.
	Improper electrical connections.	Check all connections with the wiring diagram
Hook lifts but will not lower.	Lowering circuit open.	Check circuit for loose connections. Check lower limit switch (if provided).
	Broken conductor in pendant cable.	Check continuity of each conductor in the cable. If one is broke, replace the cable.
	Improper electrical connections.	Check all connections with the wiring diagram
	Lowering circuit open.	Check circuit for loose connections. Check lower limit switch (if provided).
	Broken conductor in pendant cable.	Check continuity of each conductor in the cable. If one is broke, replace the cable.

Table 8.1
Troubleshooting Guide (Continued)

Hoist will not lift rated load or does not have proper lifting speed.	Hoist overloaded.	Reduce the load to within rated capacity of the hoist.
	Low voltage.	Determine the cause of low voltage and correct to within 10% of the specified voltage on the nameplate. Measure voltage at hoist contactor.
	Motor brake not releasing.	Check the brake components.
Excessive drift when stopping.	Excessive load.	Reduce load to the rated load shown on the nameplate.
	Motor brake not holding.	Check the brake components.
	Motor brake not setting due to insufficient plunger air gap.	Adjust air gap.
Excessive wear of the load chain.	Inadequate lubrication.	Replace load chain and lubricate.
	Side-pulling or abuse.	Replace load chain and avoid improper operation.
Oil leaks.	Worn or damaged gaskets and/or oil seals.	Replace worn or damaged parts.
	Joints not tight.	Tighten bolts to recommended torque.
Hoist motor overheats.	Excessive load.	Reduce load to the rated load shown on the nameplate.
	Excessive duty-cycle.	Reduce frequency of lift.
	Excessive "jogging."	Reduce frequency of jogs.
	Wrong voltage or frequency.	Check voltage and frequency rating on motor data plate against the power supply.
	Damaged motor or worn bearings in motor or hoist frame.	Disassemble the hoist and inspect for worn or damaged parts.
	Motor brake not releasing.	Check the brake components.
	Extreme external heating.	If the ambient temperature exceeds 100°F, frequency of hoist operation must be limited to avoid overheating. Special provisions may be required to ventilate the hoist or shield it from the heat source.
Trolley brake does not release.	Power failure in power lines.	Check circuit breakers, switches and connections in the power lines.
	Improper, loose or broken wire connections.	Check connections and lead wires. Check connections in control devices.
	Wrong voltage or frequency.	Check voltage and frequency rating on motor data plate against the power supply.
	Broken or damaged parts.	Inspect and replace parts as necessary.
Trolley does not track on beam, or bumps as it travels on the beam.	Excessive wear of trolley wheel treads or flat spots on trolley wheel treads.	Inspect trolley wheels and replace as necessary.

9.0 WIRING DIAGRAMS

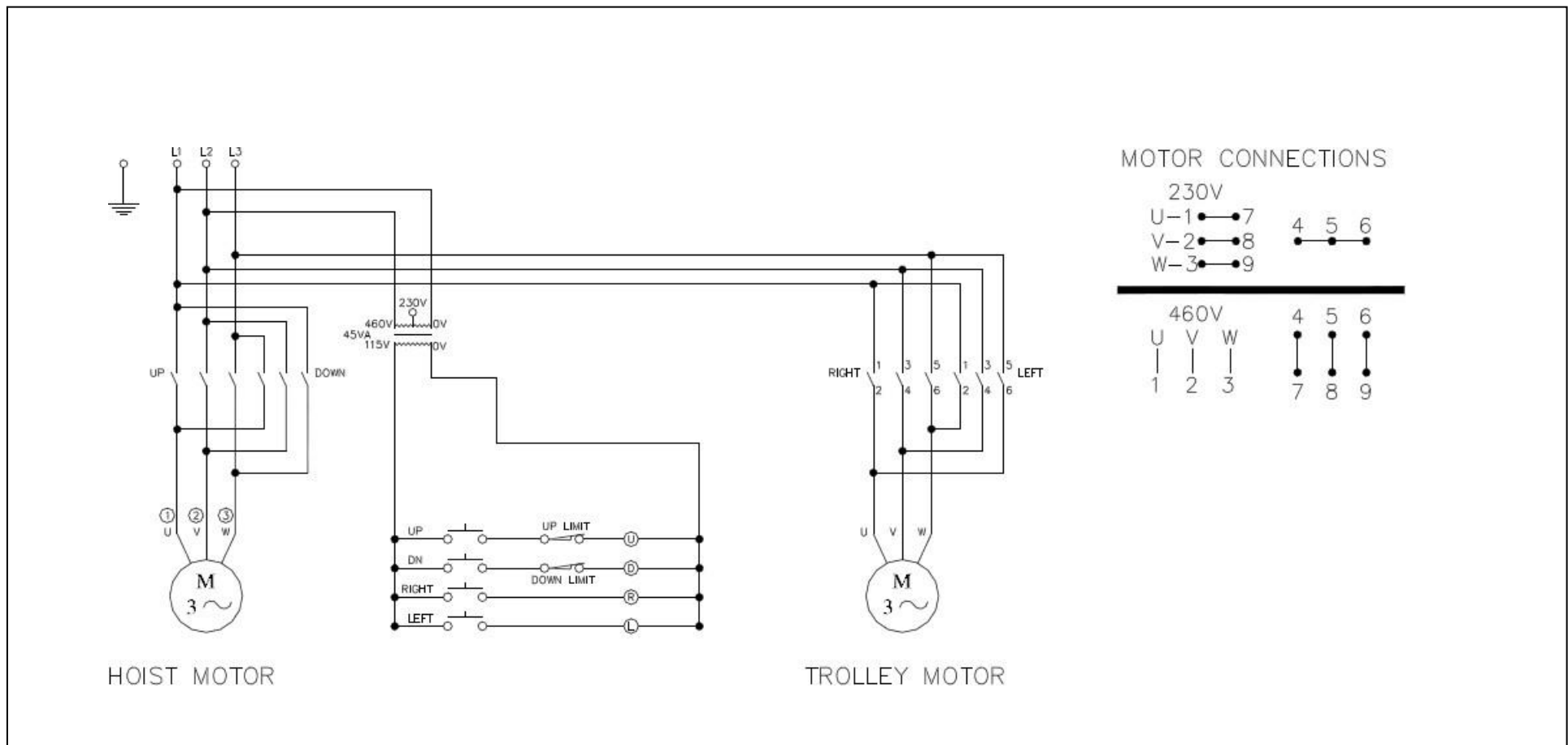

Figure 9.1

10.0 DIMENSIONS & SPECIFICATIONS

10.1 Table of Specifications

The specifications in the following table are applicable to all electrical chain hoists.

Table 10.1.1

Item		Specification
Range of Working Humidity (%)		85 or less
Range of Working Temperature (°F)		-4 to 104
Protection Class	Hoist	Nema 3
Power Supply		3 Phase, 240 - 480 V, 60 Hz
Noise Degree (dB)	Single Speed Hoist	80
	Double Speed Hoist	81

- If working temperature and humidity are over the values of the table, contact Distributer.
- The hoists are design to vertically lift loads in normal atmosphere and working conditions.
- The standard of noise degree is the value measured at 3 feet from the hoist under Normal operation.

10.2 Hoist Specifications

Table 10.2.1 Hoist Specifications

Capacity (Ton)	Model Number	No. of Chain Falls	Lift Speed (FPM)	HP	Rated Current		Weight (lbs)
					460V (Amp)	230V (Amp)	
1/2	NECHH*-01026-†	1	26	1	3.2	1.8	134
1	NECHH*-02013-†	2	13	1	3.2	1.8	134
1	NECHH*-02026-†	1	26	2	6.4	3.2	134
2	NECHH*-04013-†	2	13	2	6.4	3.2	161
2	NECHH*-04026-†	1	26	4	12.8	6.4	254
3	NECHH*-06009-†	3	9	2	6.4	3.2	187
3	NECHH*-06017-†	2	17	4	12.8	6.4	289
5	NECHH*-10010-†	2	10	4	12.8	6.4	333
7 1/2	NECHH*-15007-†	3	7	4	12.8	6.4	390
10	NECHH*-20010-†	4	10	2X4	32.8	12.8	661
15	NECHH*-30007-†	6	7	2X4	32.8	12.8	842
20	NECHH*-40005-†	8	5	2X4	32.8	12.8	1025
25	NECHH*-50005-†	8	5	2X4	32.8	12.8	1069
30	NECHH*-60003-†	10	3	2X4	32.8	12.8	2116
35	NECHH*-70003-†	10	3	2X4	32.8	12.8	2535

To complete your Model Number insert the following in place of asterisks.

- * For Suspension
- H = Hook Mounted
- L = Lug Mounted
- M = With Motorized Trolley
- P = With Standard Push Trolley
- G = With Geared Trolley

† Lift in FT

10.3 Hoist Dimensions

¼ Ton – 5 Ton Hoist with Motorized Trolley

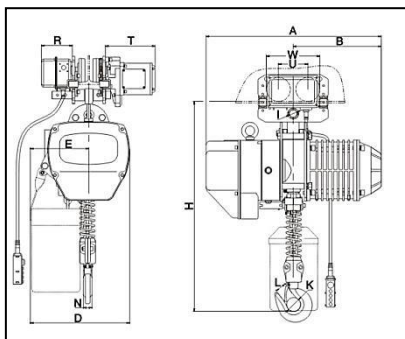

Figure 10.3.1

7.5 Ton Hoist with Motorized Trolley

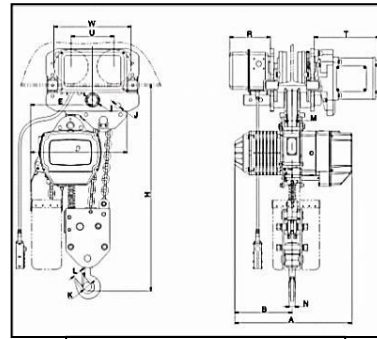

Figure 10.3.2

Table 10.3.1 Hoist Dimensions

Cap. (Ton)	Model Number	H	A	B	K	L	N	I	J	W	U	R	T
1/2	NECHM-01026- †	21.3	18.1	9.1	φ 1.4	1.0	0.7	φ 1.4	1.1	8.1	4.5	5.6	9.1
1	NECHM-02013- †	22.1	18.1	9.1	φ 1.6	1.2	0.9	φ 1.6	1.2	8.1	4.5	5.6	9.1
1	NECHM-02026- †	21.3	20.5	10.2	φ 1.7	1.3	0.7	φ 1.7	1.3	8.1	4.5	5.6	9.1
2	NECHM-04013- †	28.6	20.5	10.2	φ 1.9	1.6	1.2	φ 1.9	1.6	9.3	5.4	5.6	9.1
2	NECHM-04026- †	26.8	24.2	11.6	φ 1.9	1.6	1.2	φ 1.9	1.6	9.3	5.4	5.6	9.1
3	NECHM-06009- †	33.5	20.5	10.2	φ 2.3	1.9	1.4	φ 2.3	1.9	10.4	6.2	5.6	9.1
3	NECHM-06017- †	33.1	24.2	11.6	φ 2.3	1.9	1.4	φ 2.3	1.9	10.4	6.2	5.6	9.1
5	NECHM-10010- †	36.5	24.2	11.6	φ 2.4	1.9	1.7	φ 2.3	1.9	11.7	7.0	5.6	9.1
7.5	NECHM-15007- †	43.7	24.2	11.6	φ 3.3	3.1	2.2	φ 2.4	1.2	11.7	7.0	5.6	9.1

10 Ton Hook Mounted Hoist

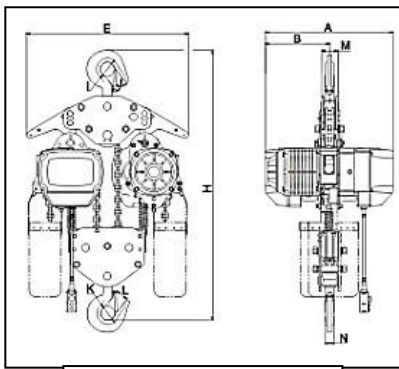

Figure 10.3.3

Table 10.3.2 Hoist Dimensions

Cap. (Ton)	Model Number	H	A	B	E	I	J	K	L	M	N
10	NECH-20010- †	51.6	24.8	12.4	35	φ 3.3	3.1	φ 3.3	3.1	4.1	2.2

10 Ton Hoist with Motorized Trolley

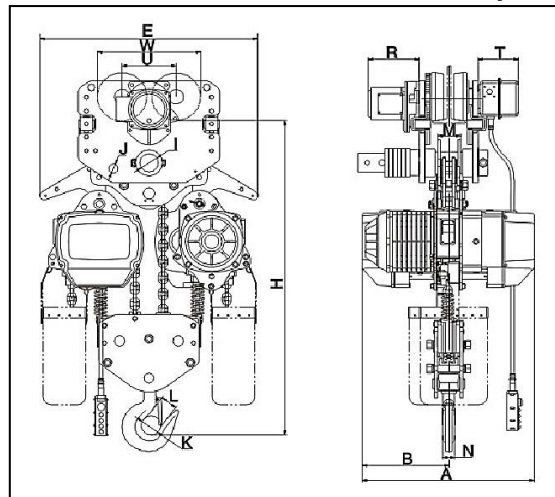

Figure 10.3.4

Table 10.3.3 Hoist Dimensions

Cap. (Ton)	Model Number	H	A	B	E	I	J	K	L	M	N	W	U	R	T
10	NECHM-20010-†	43.4	24.8	12.4	35	φ2.8	φ1.4	φ3.35	3.1	3.3	2.2	14.4	7.5	9.1	5.6

Hoists with Motorized Trolleys

15 Ton

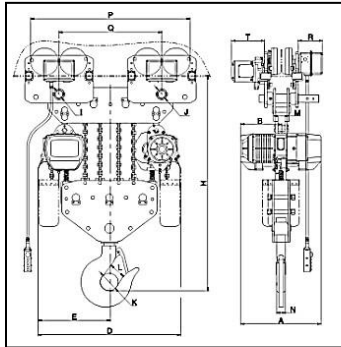

Figure 10.3.5

20 Ton

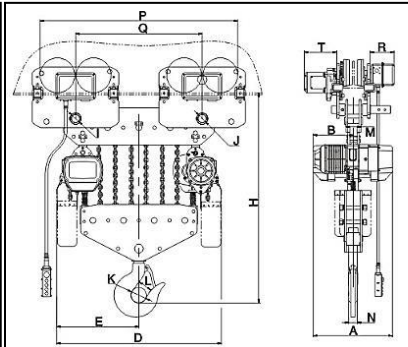

Figure 10.3.6

25 Ton

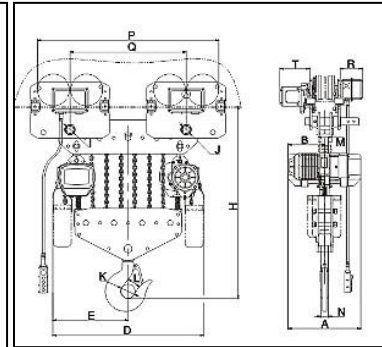

Figure 10.3.7

Table 10.3.4 Hoist Dimensions

Cap. (Ton)	Model Number	H	A	B	D	E	I	J	K	L	M	N	P	Q	R	T
15	NECHM-30007-†	48.1	24.8	12.4	42.1	21.1	φ2.1	φ2.1	φ4.7	3.8	3.5	3.1	36.5	22	5.6	9.1
20	NECHM-40005-†	54.4	24.8	12.4	49.6	24.8	φ2.8	φ2.8	φ5.9	4.5	3.5	3.7	43.5	29	5.6	9.1
25	NECHM-50005-†	54.4	24.8	12.4	49.6	24.8	φ2.8	φ2.8	φ5.9	4.5	3.5	3.7	43.5	29	5.6	9.1

30 Ton

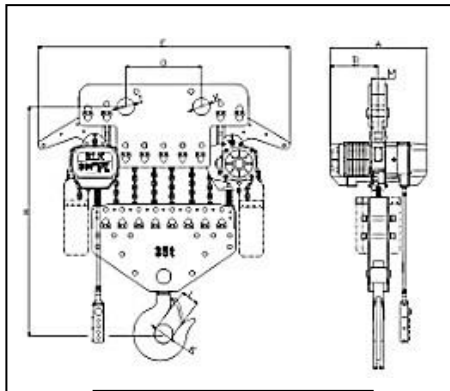

Figure 10.3.8

35 Ton

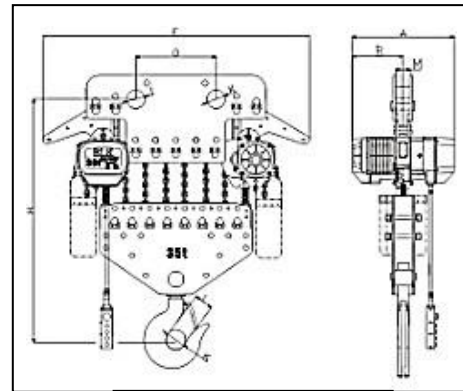

Figure 10.3.9

Table 10.3.5 Hoist Dimensions

Cap. (Ton)	Model Number	H	A	B	E	I	J	K	L	M	N
30	NECHM-60003-†	61.1	24.8	12.4	59.4	φ3.9	φ3.9	φ7.7	5.5	7.3	5.5
35	NECHM-70003-†	61.1	24.8	12.4	59.4	φ3.9	φ3.9	φ7.7	5.5	7.3	5.5

11.0 EXPLODED VIEWS & PARTS LISTS

11.1 Exploded View: Motor & Body Assembly

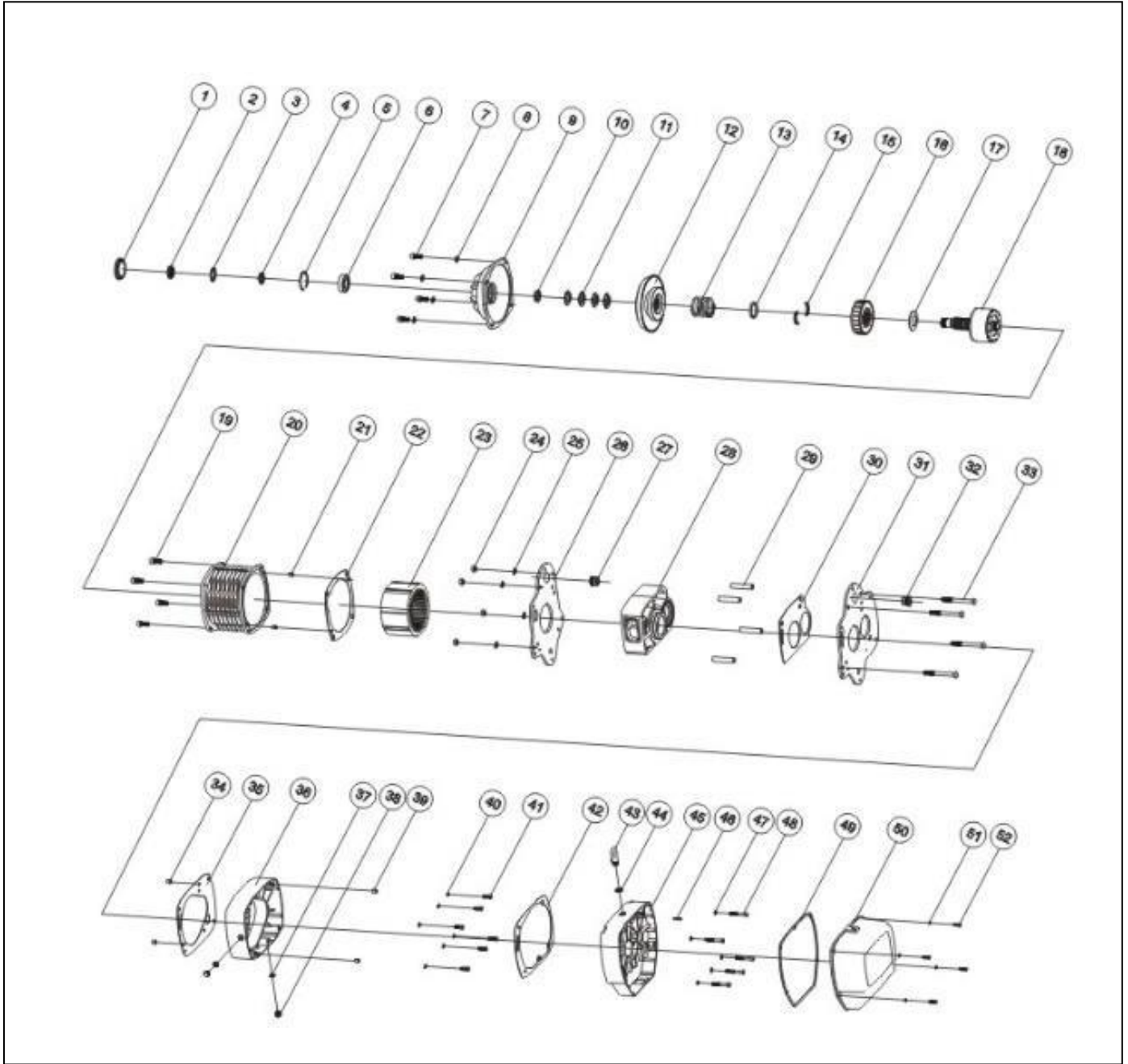

Figure 11.1

11.2 Parts List: Motor and Body Assembly

Table 11.2.1
Motor and Body Assembly Parts List: 1-
2 HP

Hoist Model			NECH-00526 NECH-02013	NECH-01016 NECH-01026	NECH-02016 NECH-02026	NECH-04008 NECH-04013	NECH-06005 NECH-06009
Item	Spare Parts Name	Quantity	0.25 TO 1 TON 1HP MOTOR		2 TO 3 TON 2HP MOTOR		
1	Rubber cover	1	KD1-001		KD1-101		
2	Nut	2	KD1-002		KD1-102		
3	Motor back end locking plate	1	KD1-003		KD1-103		
4	Ring upper washer	1	KD1-004		KD1-104		
5	Circlip for hole	1	KD1-005		KD1-105		
6	Deep groove ball bearing	1	KD1-006		KD1-106		
7	Socket head cap screw	4	KD1-007		KD1-107		
8	Spring washer	4	KD1-008		KD1-108		
9	Motor cover	1	KD1-009		KD1-109		
10	Rotor washer	1	KD1-010		KD1-110		
11	Plate spring	4	KD1-011		KD1-111		
12	Brake pad assembly	1	KD1-012		KD1-112		
13	Brake spring	1	KD1-013		KD1-113		
14	Brake magnet locking sleeve	1	KD1-014		KD1-114		
15	Brake magnet split ring	1	KD1-015		KD1-115		
16	Brake magnet coil	1	KD1-016		KD1-116		
17	Plate spring	1	KD1-017		KD1-117		
18	Rotor assembly	1	KD1-018		KD1-118		
19	Socket head cap screw	4	KD1-019		KD1-119		
20	Motor shell	1	KD1-020		KD1-120		
21	Spring-type straight pin	2	KD1-021		KD1-121		
22	Gasket A	1	KD1-022		KD1-122		
23	Motor stator	1	KD1-023		KD1-123		
24	Hex nut	4	KD1-024		KD1-124		
25	Spring washer	4	KD1-025		KD1-125		
26	Motor bottom plate	4	KD1-026		KD1-126		
27	Upper hook bearing bush	1	KD1-027		KD1-127		
28	Chain wheel case	1	KD1-028		KD1-128		
29	Sleeve	4	KD1-029		KD1-129		
30	Gasket B	1	KD1-030		KD1-130		

Table 11.2.1 (continued)
 Motor and Body Assembly Parts
 List: 1-2 HP

Hoist Model			NECH-00526 NECH-02013	NECH-01016 NECH-01026	NECH-02016 NECH-02026	NECH-04008 NECH-04013	NECH-06005 NECH-06009
Item	Spare Parts Name	Quantity	0.25 TO 1 TON 1HP MOTOR		2 TO 3 TON 2HP MOTOR		
31	Bottom plate for gear box	1	KD1-031		KD1-131		
32	Upper hook bearing bush	1	KD1-032		KD1-132		
33	Sleeve bolt	4	KD1-033		KD1-133		
34	Dowel pin	2	KD1-034		KD1-134		
35	Gasket C	1	KD1-035		KD1-135		
36	Middleware	1	KD1-036		KD1-136		
37	Hex screw washer	2	KD1-037		KD1-137		
38	Hex screw	2	KD1-038		KD1-138		
39	Dowel pin	2	KD1-039		KD1-139		
40	Spring washer	6	KD1-040		KD1-140		
41	Socket head cap bolt	6	KD1-041		KD1-141		
42	Gasket D	1	KD1-042		KD1-142		
43	Eye bolt	1	KD1-043		KD1-143		
44	Eye bolt gasket	1	KD1-044		KD1-144		
45	Gear box	1	KD1-045		KD1-145		
46	Dowel pin	1	KD1-046		KD1-146		
47	External toothed washer	5	KD1-047		KD1-147		
48	Socket head cap bolt	5	KD1-048		KD1-148		
49	Gasket E	1	KD1-049		KD1-149		
50	Electrical section cover	1	KD1-050		KD1-150		
51	Spring washer	4	KD1-051		KD1-151		
52	Socket head cap bolt	4	KD1-052		KD1-152		

Table 11.2.2
 Motor and Body Assembly Parts List: 4
 HP

Hoist Model			NECH-04026 NECH-06017	NECH-10010 NECH-15007	NECH-20010 NECH-30007	NECH-40005
Item	Spare Parts Name	Quantity	3 TO 7.5 TONS 4HP – 1 MOTOR		10 TO 20 TONS 4HP – 2 MOTORS	
1	Rubber cover	1	KD1-201			
2	Nut	2	KD1-202			
3	Motor back end locking plate	1	KD1-203			
4	Ring upper washer	1	KD1-204			
5	Circlip for hole	1	KD1-205			
6	Deep groove ball bearing	1	KD1-206			
7	Socket head cap screw	4	KD1-207			
8	Spring washer	4	KD1-208			
9	Motor cover	1	KD1-209			
10	Rotor washer	1	KD1-210			
11	Plate spring	4	KD1-211			
12	Brake pad assembly	1	KD1-212			
13	Brake spring	1	KD1-213			
14	Brake magnet locking sleeve	1	KD1-214			
15	Brake magnet split ring	1	KD1-215			
16	Brake magnet coil	1	KD1-216			
17	Plate spring	1	KD1-217			
18	Rotor assembly	1	KD1-218			
19	Socket head cap screw	4	KD1-219			
20	Motor shell	1	KD1-220			
21	Spring-type straight pin	2	KD1-221			
22	Gasket A	1	KD1-222			
23	Motor stator	1	KD1-223			
24	Hex nut	4	KD1-224			
25	Spring washer	4	KD1-225			
26	Motor bottom plate	4	KD1-226			
27	Upper hook bearing bush	1	KD1-227			
28	Chain wheel case	1	KD1-228			
29	Sleeve	4	KD1-229			

Table 11.2.2 (continued)
 Motor and Body Assembly Parts
 List: 4 HP

Hoist Model			NECH-04026 NECH-06017	NECH-10010 NECH-15007	NECH-20010 NECH-30007	NECH-40005
Item	Spare Parts Name	Quantity	3 TO 7.5 TONS 4HP – 1 MOTOR		10 TO 20 TONS 4HP – 2 MOTORS	
30	Gasket B	1	KD1-230			
31	Bottom plate for gear box	1	KD1-231			
32	Upper hook bearing bush	1	KD1-232			
33	Sleeve bolt	4	KD1-233			
34	Dowel pin	2	KD1-234			
35	Gasket C	1	KD1-235			
36	Middleware	1	KD1-236			
37	Hex screw washer	2	KD1-237			
38	Hex screw	2	KD1-238			
39	Dowel pin	2	KD1-239			
40	Spring washer	6	KD1-240			
41	Socket head cap bolt	6	KD1-241			
42	Gasket D	1	KD1-242			
43	Eye bolt	1	KD1-243			
44	Eye bolt gasket	1	KD1-244			
45	Gear box	1	KD1-245			
46	Dowel pin	1	KD1-246			
47	External toothed washer	5	KD1-247			
48	Socket head cap bolt	5	KD1-248			
49	Gasket E	1	KD1-249			
50	Electrical section cover	1	KD1-250			
51	Spring washer	4	KD1-251			
52	Socket head cap bolt	4	KD1-252			

11.3 Exploded View: Chain Assembly

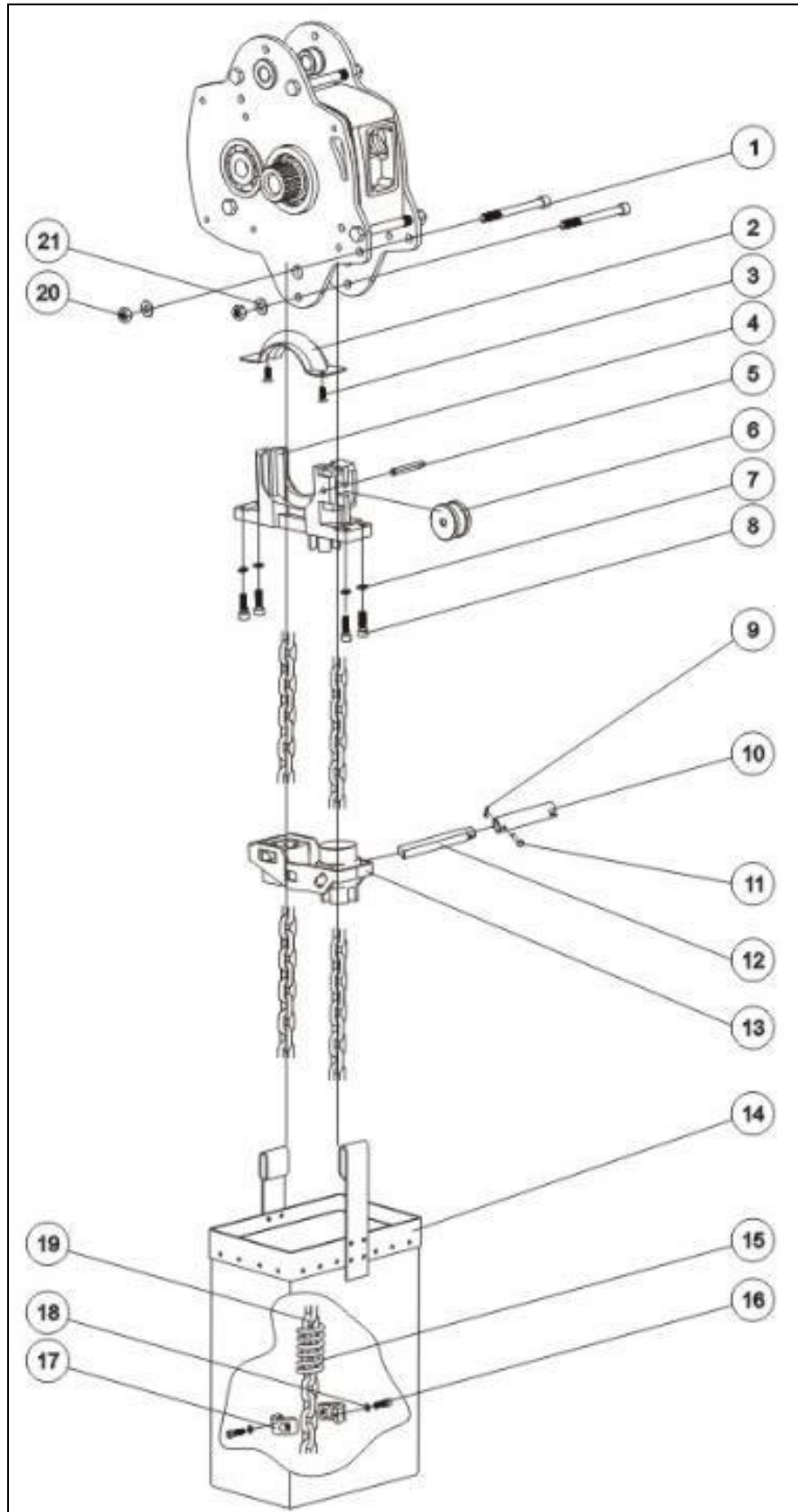

Figure 11.3.1

11.4 Parts List: Chain Assembly

Table 11.4.1
Chain Assembly Parts List: 6.3-7.1 mm

Hoist Model			NECH-00526	NECH-01016 NECH-01026	NECH-02013 NECH-02016	NECH-04008 NECH-06009
Item	Spare Parts Name	Quantity	0.5 TO 1 TON 6.3mm chain		1 TO 3 TON 7.1mm chain	
1	Socket head cap screws	2	KD5-001		KD5-101	
2	Oriented iron	2	KD5-002		KD5-102	
3	Slotted countersunk head screws	1	KD5-003		KD5-103	
4	Chain Guide	1	KD5-004		KD5-104	
5	Pulley Shaft	1	KD5-005		KD5-105	
6	Oriented Pulley	1	KD5-006		KD5-106	
7	Spring Washer	4	KD5-007		KD5-107	
8	socket head cap screws	4	KD5-008		KD5-108	
9	split pin	1	KD5-009		KD5-109	
10	Limit switches connecting shaft	1	KD5-010		KD5-110	
11	Axis of the Middle pin	1	KD5-011		KD5-111	
12	Middle pin of guide frame	1	KD5-012		KD5-112	
13	Guide frame assembly	1	KD5-013		KD5-113	
14	Chain bag	1	KD5-014		KD5-114	
15	Limit Spring	1	KD5-015		KD5-115	
16	socket head cap screws	2	KD5-016		KD5-116	
17	Chain split ring	2	KD5-017		KD5-117	
18	Spring Washer	2	KD5-018		KD5-118	
19	Chain		10 ft standard			
20	Nut	2	KD5-019		KD5-119	
21	Spring Washer	2	KD5-020		KD5-120	

Table 11.4.2
Chain Assembly Parts List: 10.0-11.2 mm

Hoist Model			NECH-02026 NECH-04013 NECH-04026	NECH-06005 NECH-06017	NECH-10010 NECH-15007	NECH-20010 NECH-30007 NECH-40005
Item	Spare Parts Name	Quantity	1 TO 3 TON 10.0 mm chain		5 to 7.5 TON 11.2 mm chain	10 to 20 TON 11.2 mm chain
1	Socket head cap screws	2	KD5-201		KD5-301	
2	Oriented iron	2	KD5-202		KD5-302	
3	Slotted countersunk head screws	1	KD5-203		KD5-303	
4	Chain Guide	1	KD5-204		KD5-304	
5	Pulley Shaft	1	KD5-205		KD5-305	
6	Oriented Pulley	1	KD5-206		KD5-306	
7	Spring Washer	4	KD5-207		KD5-307	
8	socket head cap screws	4	KD5-208		KD5-308	
9	split pin	1	KD5-209		KD5-309	
10	Limit switches connecting shaft	1	KD5-210		KD5-310	
11	Axis of the Middle pin	1	KD5-211		KD5-311	
12	Middle pin of guide frame	1	KD5-212		KD5-312	
13	Guide frame assembly	1	KD5-213		KD5-313	
14	Chain bag	1	KD5-214		KD5-314	
15	Limit Spring	1	KD5-215		KD5-315	
16	socket head cap screws	2	KD5-216		KD5-316	
17	Chain split ring	2	KD5-217		KD5-317	
18	Spring Washer	2	KD5-218		KD5-318	
19	Chain		10 ft standard			
20	Nut	2	KD5-219		KD5-319	
21	Spring Washer	2	KD5-220		KD5-320	

11.5 Exploded View: Hook Assembly

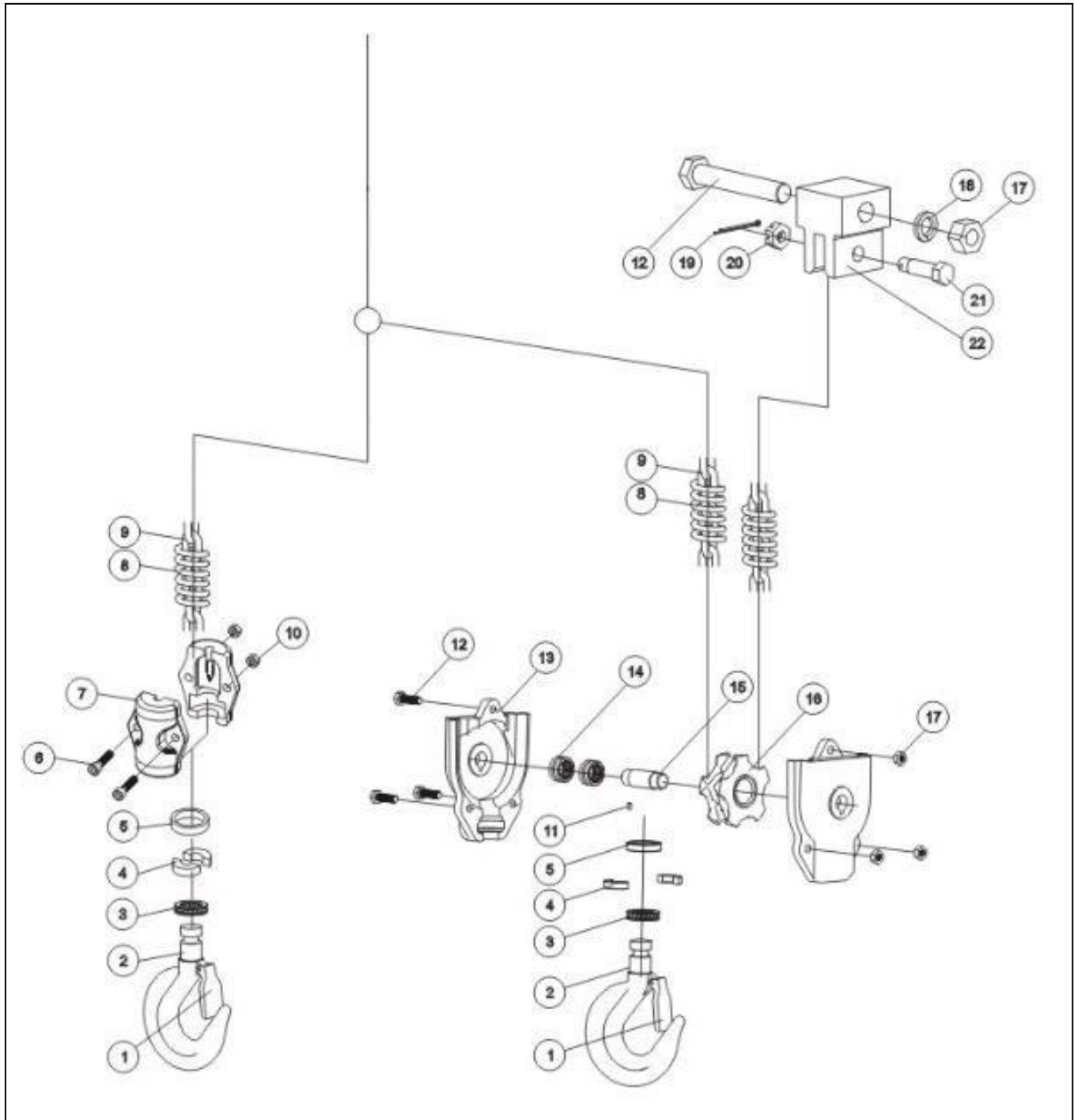

Figure 11.5.1

11.6 Parts List: Hook Assembly

Table 11.6.1
Hook Assembly Parts List: 0.5-2 ton

Hoist Model			NECH-00526 NECH-01016 NECH-01026	NECH-02016 NECH-02026	NECH-04026	NECH-04008 NECH-04013
Item	Spare Parts Name	Quantity	0.5 TON - 1 part	1 TON - 1 part	2 TON - 1 part	2 TON - 2 part
1	Hook safety latch	1	KD2-001	KD2-101	KD2-201 KD2-301	
2	Lower hook	1	KD2-002	KD2-102	KD2-202	
3	Thust ball bearing	1	KD2-003	KD2-103	KD2-203	
4	Lower hook split ring	2	KD2-004	KD2-104	KD2-204	
5	Lower hook locking sleeve	1	KD2-005	KD2-105	KD2-205	
6	Socket head cap screw	2	KD2-006	KD2-106	KD2-206	-
7	Lower hook swivel shell	2	KD2-007	KD2-107	KD2-207	-
8	Chain limit spring	1	KD2-008	KD2-108	KD2-208	KD2-208*2
9	Chain		10 ft standard			
10	Self-locking nut	2	KD2-010	KD2-110	KD2-210	-
11	Slotted spring pins	1		-		KD2-211
12	Outer hexagonal bolt	4		-		KD2-212
13	Lower load block shell	2		-		KD2-213
14	Needle bearing	2		-		KD2-214
15	Lower load block chain wheel shaft	1		-		KD2-215
16	Lower load chain wheel	1		-		KD2-216
17	Hex nut	4		-		KD2-217
18	Spring washer	1		-		KD2-218
19	Split pin	1		-		KD2-219
20	Hex slotted nut	1		-		KD2-220
21	Chain bolt	1		-		KD2-221
22	Chain locking block	1		-		KD2-222

Table 11.6.2
Hook Assembly Parts List: 2.5-5 ton

Hoist Model			NECH-06017			NECH-10010
Item	Spare Parts Name	Quantity	2.5 ton-1 part	3 ton-1 part	3 ton-2 part	5 ton-2 part
1	Hook safety latch	1	KD2-301			KD2-501
2	Lower hook	1	KD2-302			KD2-502
3	Thrust ball bearing	1	KD2-303			KD2-503
4	Lower hook split ring	2	KD2-304			KD2-504
5	Lower hook locking sleeve	1	KD2-305			KD2-505
6	Socket head cap screw	2	KD2-306		-	
7	Lower hook swivel shell	2	KD2-307		-	
8	Chain limit spring	1	KD2-308		KD2-308*2	KD2-508*2
9	Chain	10 ft standard				
10	Self-locking nut	2	KD2-310		-	
11	Slotted spring pins	1	-		KD2-311	KD2-511
12	Outer hexagonal bolt	4	-		KD2-312	KD2-512
13	Lower load block shell	2	-		KD2-313	KD2-513
14	Needle bearing	2	-		KD2-314	KD2-514
15	Lower load block chain wheel shaft	1	-		KD2-315	KD2-515
16	Lower load chain wheel	1	-		KD2-316	KD2-516
17	Hex nut	4	-		KD2-317	KD2-517
18	Spring washer	1	-		KD2-318	KD2-518
19	Split pin	1	-		KD2-319	KD2-519
20	Hex slotted nut	1	-		KD2-320	KD2-520
21	Chain bolt	1	-		KD2-321	KD2-521
22	Chain locking block	1	-		KD2-322	KD2-522

11.7 Exploded View: 3-part Hook Assembly

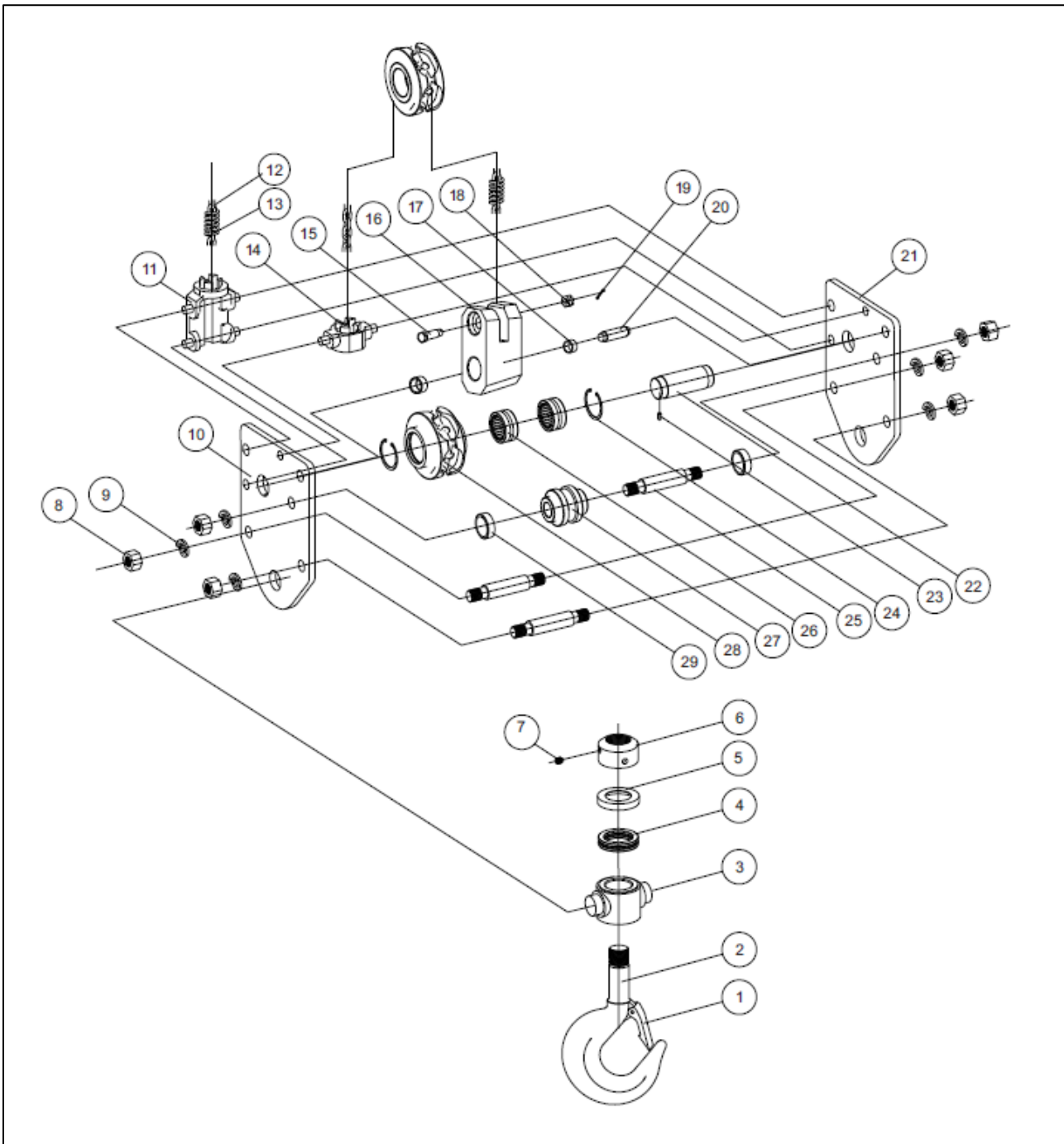

Figure 11.5.2

Table 11.7.1
Hook Assembly Parts List

Item	Spare Parts Name	Quantity	Every Type Hoist Use Quantity		
			3t – 3 part		7.5t – 3 part
Hoist Model			NECH-06005	NECH-06009	NECH-15007
1	Hook safety latch	1	KD3-301		KD3-701
2	lower hook	1	KD3-302		KD3-702
3	Hook to undertake block	1	KD3-303		KD3-703
4	thrust ball bearing	1	KD3-304		KD3-704
5	Bearing sheath	1	KD3-305		KD3-705
6	Hook nut	1	KD3-306		KD3-706
7	Hex-end tight set screws	1	KD3-307		KD3-707
8	Hex nut	6	KD3-308		KD3-708
9	Spring washer	6	KD3-309		KD3-709
10	Stent motherboard under	1	KD3-310		KD3-710
11	Chain guiding for inlet and outlet	1	KD3-311		KD3-711
12	Chain	30 feet standard			
13	Limit spring	1	KD3-312		KD3-712
14	Guide chain body	1	KD3-313		KD3-713
15	Chain bolt	1	KD3-314		KD3-714
16	Chain locking block	1	KD3-315		KD3-715
17	Locking block of gasket	1	KD3-316		KD3-716
18	Hex slotted nut	1	KD3-317		KD3-717
19	Split pin	1	KD3-318		KD3-718
20	Locking block of shaft	1	KD3-319		KD3-719
21	Stent vice board under	1	KD3-320		KD3-720
22	lower hook chain wheel shaft	1	KD3-321		KD3-721
23	Spring straight pins	1	KD3-322		KD3-722
24	Circlip for hole	2	KD3-323		KD3-723
25	Stents double nut	3	KD3-324		KD3-724
26	Needle bearing	2	KD3-325		KD3-725
27	Guiding pulley	1	KD3-326		KD3-726
28	Chain wheel	1	KD3-327		KD3-727
29	Circlip	2	KD3-328		KD3-728

11.8 Exploded View: Gear Box Assembly

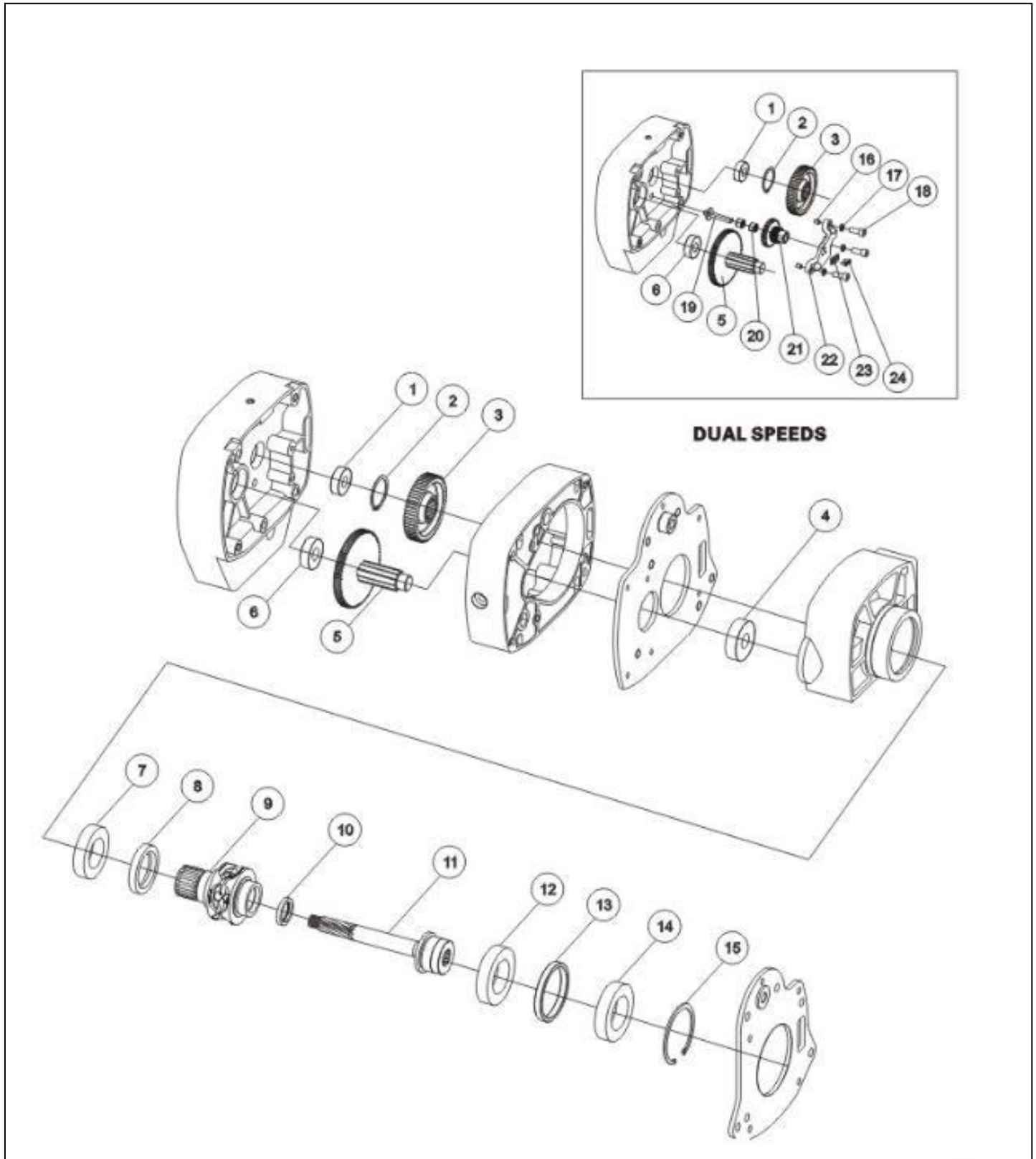

Figure 11.8.1

11.9 Parts List: Gear Box Assembly

Table 11.9.1
Gear Box Assembly Parts List: 6.3-7.1 mm

Hoist Model			NECH-00526 NECH-02013	NECH-01016 NECH-01026	NECH-04008 NECH-04013	NECH-02016 NECH-02013	NECH-04008 NECH-06009
Item	Spare Parts Name	Quantity	0.5 TO 1 TON 6.3mm chain		1 TO 3 TON 7.1mm chain		
1	Deep groove ball bearing	1	KD4-001		KD4-101		
2	circlip for shaft	1	KD4-002		KD4-102		
3	Output gear	1	KD4-003		KD4-103		
4	Deep groove ball bearing	1	KD4-004		KD4-104		
5	Gear-gear shaft	1	KD4-005		KD4-105		
6	Deep groove ball bearing	1	KD4-006		KD4-106		
7	Deep groove ball bearing	1	KD4-007		KD4-107		
8	Oil seal	1	KD4-008		KD4-108		
9	Chain wheel	1	KD4-009		KD4-109		
10	Oil seal	1	KD4-010		KD4-110		
11	Output shaft assembly	1	KD4-011		KD4-111		
12	Deep groove ball bearing	1	KD4-012		KD4-112		
13	Bearings fixed ring	1	KD4-013		KD4-113		
14	Deep groove ball bearing	1	KD4-A014		KD4-A114		
15	Circlip for hole	1	KD4-015		KD4-115		
16	Spring straight pins	2	KD4-016		KD4-116		
17	Spring washer	3	KD4-017		KD4-117		
18	socket head cap screws	3	KD4-018		KD4-118		
19	Reduction gear fixed axis	1	KD4-019		KD4-119		
20	Bearing	2	KD4-020		KD4-120		
21	Dual gears	1	KD4-021		KD4-121		
22	Reduction gear fixed frame	1	KD4-022		KD4-122		
23	Reduction gear fixed stator	1	KD4-023		KD4-123		
24	Cross Recessed Countersunk Screw	1	KD4-024		KD4-124		

Table 11.9.2
Gear Box Assembly Parts List: 10-11.2 mm

Hoist Model			NECH-02026 NECH-04013	NECH-06005 NECH-04026	NECH-10010 NECH-15007	NECH-20010 NECH-30007	NECH-40005
Item	Spare Parts Name	Quantity	2 TO 3 TON 10.0 mm chain		5 to 20 TON 11.2 mm chain		
1	Deep groove ball bearing	1	KD4-201				
2	circlip for shaft	1	KD4-202				
3	Output gear	1	KD4-203		KD4-303		
4	Deep groove ball bearing	1	KD4-204				
5	Gear-gear shaft	1	KD4-205		KD4-305		
6	Deep groove ball bearing	1	KD4-206				
7	Deep groove ball bearing	1	KD4-207				
8	Oil seal	1	KD4-208				
9	Chain wheel	1	KD4-209		KD4-309		
10	Oil seal	1	KD4-210				
11	Output shaft assembly	1	KD4-211		KD4-311		
12	Deep groove ball bearing	1	KD4-212				
13	Bearings fixed ring	1	KD4-213				
14	Deep groove ball bearing	1	KD4-214				
15	Circlip for hole	1	KD4-215				
16	Spring straight pins	2	KD4-216				
17	Spring washer	3	KD4-217				
18	socket head cap screws	3	KD4-218				
19	Reduction gear fixed axis	1	KD4-219				
20	Bearing	2	KD4-220				
21	Dual gears	1	KD4-221				
22	Reduction gear fixed frame	1	KD4-222				
23	Reduction gear fixed stator	1	KD4-223				
24	Cross Recessed Countersunk Screw	1	KD4-224				

11.10 Exploded View: Electric Control Station

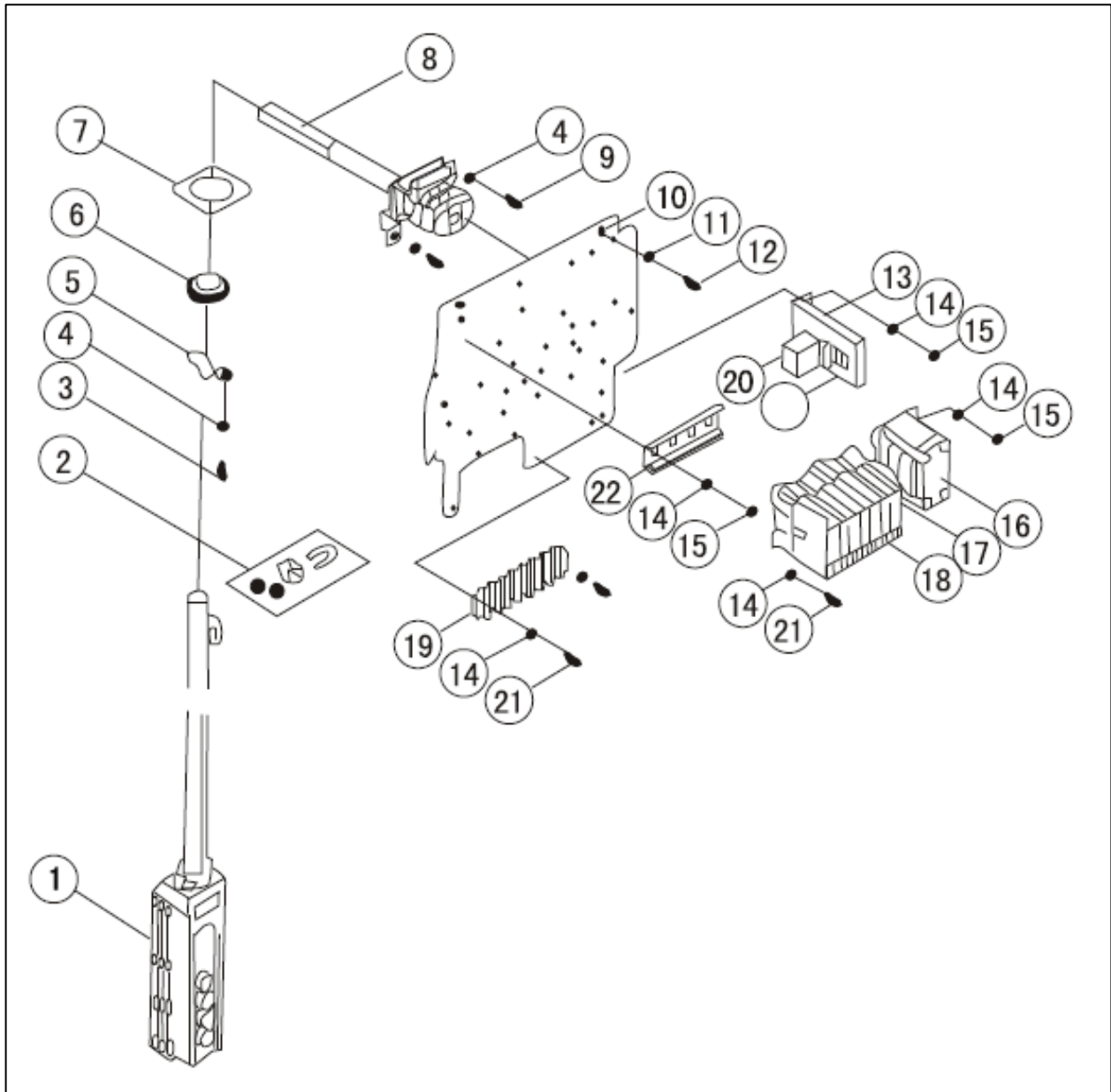

Figure 11.9.1

11.11 Parts List: Electric Control Station

Table 11.11.1
Electric Control Station Parts List: 6.3-7.1 mm

Hoist Model			NECH-00526 NECH-02013	NECH-01016 NECH-01026	NECH-04008 NECH-04013	NECH-02016 NECH-02013	NECH-04008 NECH-06009
Item	Spare Parts Name	Quantity	0.5 TO 1 TON 6.3mm chain		1 TO 3 TON 7.1mm chain		
1	Control switch	1	KD6-001		KD6-101		
2	Tightrope Buckle	1	KD6-002		KD6-102		
3	Round cross screw M6*12	2	KD6-003		KD6-103		
4	Spring Washer	4	KD6-004		KD6-104		
5	Wiring fixed ring accessories	1	KD6-005		KD6-105		
6	Cable sheath	1	KD6-006		KD6-106		
7	Fixed wiring ring	1	KD6-007		KD6-107		
8	Connecting shaft assembly for control switch	1	KD6-008		KD6-108		
9	Round cross screw M6*10	2	KD6-009		KD6-109		
10	Electrical installation plate	1	KD6-010		KD6-110		
11	Spring Washer	4	KD6-011		KD6-111		
12	Round cross screw M6*15	4	KD6-012		KD6-112		
13	Reverse bracket B	1	KD6-013		KD6-113		
14	Spring Washer	5	KD6-014		KD6-114		
15	Round cross screw M4*10	5	KD6-015		KD6-115		
16	Transformer	1	KD6-016		KD6-116		
17	Electromagnetic contactor	2	KD6-017		KD6-117		
18	Mechanical linkage	1	KD6-018		KD6-118		
19	Terminal block	1	KD6-019		KD6-119		
20	Antiphase protector	1	KD6-020		KD6-120		
21	Round cross screw M4*15	2	KD6-021		KD6-121		
22	Fixed rail	1	KD6-022		KD6-122		

Table 11.11.2
Electric Control Station Parts List: 10-11.2 mm

Hoist Model			NECH-02026 NECH-04013	NECH-06005 NECH-04026	NECH-10010 NECH-06017 NECH-15007	NECH-20010 NECH-30007 NECH-40005
Item	Spare Parts Name	Quantity	2 TO 3 TON 10.0 mm chain		3 to 20 TON 11.2 mm chain	
1	Control switch	1	KD6-201		KD6-201*2	
2	Tightrope Buckle	1	KD6-202		KD6-202*2	
3	Round cross screw M6*12	2	KD6-203		KD6-203*2	
4	Spring Washer	4	KD6-204		KD6-204*2	
5	Wiring fixed ring accessories	1	KD6-205		KD6-205*2	
6	Cable sheath	1	KD6-206		KD6-206*2	
7	Fixed wiring ring	1	KD6-207		KD6-207*2	
8	Connecting shaft assembly for control switch	1	KD6-208		KD6-208*2	
9	Round cross screw M6*10	2	KD6-209		KD6-209*2	
10	Electrical installation plate	1	KD6-210		KD6-210*2	
11	Spring Washer	4	KD6-211		KD6-211*2	
12	Round cross screw M6*15	4	KD6-212		KD6-212*2	
13	Reverse bracket B	1	KD6-213		KD6-213*2	
14	Spring Washer	5	KD6-214		KD6-214*2	
15	Round cross screw M4*10	5	KD6-215		KD6-215*2	
16	Transformer	1	KD6-216		KD6-216*2	
17	Electromagnetic contactor	2	KD6-217		KD6-217*2	
18	Mechanical linkage	1	KD6-218		KD6-218*2	
19	Terminal block	1	KD6-219		KD6-219*2	
20	Antiphase protector	1	KD6-220		KD6-220*2	
21	Round cross screw M4*15	2	KD6-221		KD6-221*2	
22	Fixed rail	1	KD6-222		KD6-222*2	

