

UNDER-RUNNING END TRUCKS

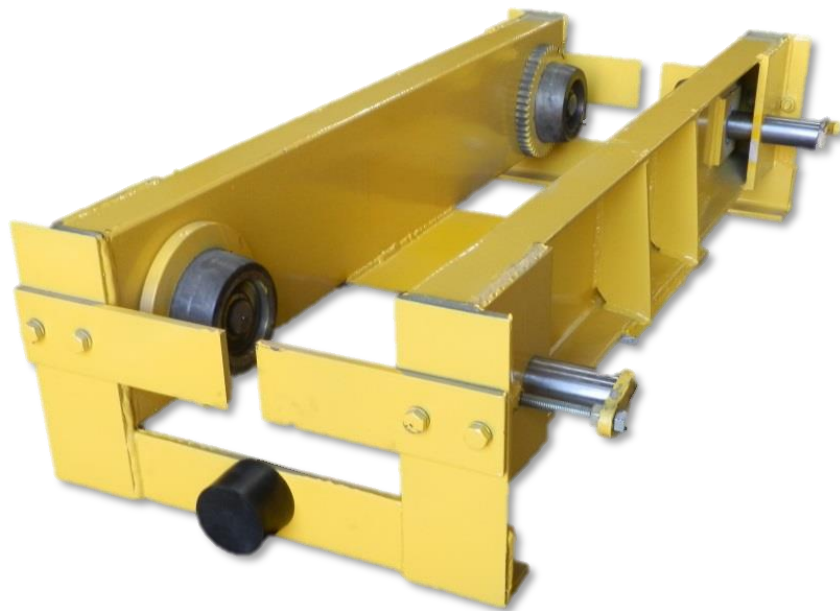

OPERATION MANUAL

This operation manual is intended as an instruction manual for trained personnel who are in charge of installation, maintenance, repair etc.



Before equipment use, please read this operation manual

Serial Number: _____
Date Purchased: _____

UNDER-RUNNING END TRUCKS

Models MEUS, MEUD

MEUS-0815

ACI Hoist & Crane | 2721 NE 4th Ave Pompano FL, 33064 | 954.367.6116



Scan QR Code with
SmartPhone for full details.

TABLE OF CONTENTS

1.0 WARRANTY	4
2.0 SAFETY PRECAUTIONS	5
2.1 Safety Alert Symbols	5
2.2 Warning Tags and Labels	5
1.0 GENERAL DESCRIPTION	7
3.1 End Trucks (Under-Running)	7
3.2 Model Numbering	7
4.0 INSTALLATION	8
4.1 Prior to Installation	8
4.2 Installing Bridge Crane	9
4.2.1 Installing Under-Running Bridge Crane	10
4.3 Connecting Power Supply to Crane	11
4.3.1 Runway Conductors	11
4.3.2 Main Collectors	11
4.3.3 Cross Conductors	11
4.3.4 Trolley Collectors	12
4.3.5 Motor	12
4.4 Outdoor Installation	12
5.0 OPERATION	13
5.1 Before Operating the Crane for First Time	13
5.1.1 Crane Drive Motor Phasing	14
5.2 Operational Test	15
5.3 Load Test	17
5.4 Safety Rules	18
5.4.1 General DO's and DO NOT's	19
5.5 Operating Controls	20
5.5.1 Operating the Controls without a Load	20
5.5.2 Operating the Controls with a Load	22
5.5.3 Operating the Crane and Moving the Load	23
5.5.4 Parking the Load	23
6.0 INSPECTION	24
6.1 Prior to Inspection	24
6.1.1 Lockout/Tagout Procedures	24
6.2 Inspection Procedure	25
6.2.1 Service & Frequency Information	26
6.3 Daily Inspection	27
6.4 Frequent Inspection	27
6.5 Periodic Inspection	28

6.6 Occasionally Used Cranes.....	28
6.7 Inspection Report & Criteria	28
6.8 End Tuck and Wheel Inspection	30
6.9 End Truck Motor	31
7.0 MAINTENANCE & REPAIR	32
7.1 Lubrication.....	32
7.1.1 Detailed Lubrication Requirements	32
7.2 Wheel Removal.....	33
7.3 Gear Motor	33
7.4 Storage.....	33
7.4.1 For Long Term Storage and Humid Environments.....	34
7.4.2 Drying Out a Motor	34
8.0 TROUBLESHOOTING	35
9.0 DIMENSIONS & SPECIFICATIONS.....	38
9.1 Under-Running Motorized End Truck Dimensions.....	38
9.2 Under-Running Hand-Pushed End Truck Dimensions.....	39
9.3 Under-Running Motorized End Truck Specifications	40
9.4 Under-Running Hand-Pushed End Truck Specifications	41
10.0 EXPLODED VIEW & PARTS LIST	42

1.0 WARRANTY

Warranty

Every end truck is thoroughly inspected and tested before it is shipped from the factory. If any problem develops within one year return the complete end truck prepaid to the factory. If an inspection reveals that the problem is caused by defective workmanship or material, repairs will be made without charge and the end truck will be returned, transportation prepaid.

Excluded Items

This warranty does not cover:

- A. Deterioration caused by normal wear, abuse, eccentric or side loading, overloading, chemical or abrasive actions, improper maintenance or excessive heat.
- B. Problems resulting from repairs, modifications or alterations made by people other than factory or ACI representatives.
- C. The end truck has been abused or damaged due to an accident.
- D. If repair parts or accessories other than ACI equipment are used on the end truck; they are warranted only to extent that they are warranted by the manufacturer of said parts or accessories.

Remarks

EXCEPT AS STATED HERE, ACI MAKES NO OTHER WARRANTIES, EXPRESS OR IMPLIED, INCLUDING WARRANTIES FOR A PARTICULAR PURPOSE.



Alterations or modifications of equipment and use of non-factory repair parts can lead to dangerous operation and injury.

To avoid injury:

DO NOT alter or modify equipment.

DO NOT use equipment to lift, support or otherwise transport people.





DO NOT suspend unattended loads over people.

2.0 SAFETY PRECAUTIONS

2.1 Safety Alert Symbols

Throughout this manual are steps and procedures that can prevent hazardous situations, the following symbols are used to identify the degree or level of hazard seriousness.

DANGER, WARNING AND CAUTION NOTICE

Symbol	Description
	Danger Indicates an imminently hazardous situation which, if not avoided, will result in death or serious injury and property damage.
	Warning Indicates an imminently hazardous situation which, if not avoided, could result in death or serious injury and property damage.
	Caution Indicates a potentially hazardous situation which, if not avoided, may result in minor or moderate injury or property damage.
	Notice Notifies people of installation, operation or maintenance information which is important but not directly hazard related.

2.2 Warning Tags and Labels

The End Trucks covered by this owner's manual may be used as part of a lifting system such as a crane. It is the responsibility of the supplier and the owner of such a lifting system to provide for and ensure that the fitting system be equipped with warning labels in accordance with applicable industry standards.



These general instructions deal with the normal installation, operation, inspection and maintenance situations encountered with the equipment described herein. The instructions should not be interpreted to anticipate every possible contingency or to anticipate the final system, crane or configuration that uses with equipment.

This manual includes instructions and parts of information for a variety of crane or monorail types. Therefore, all instructions and parts of information may not apply to any one type or size of specific crane or monorail. Disregard those portions of the instructions that do not apply.

WARNING

Failure to read and comply with any of the limitations noted in this manual can result in serious bodily injury or death, and/or property damage.

WARNING

Equipment described herein is not designed for and **MUST NOT** be used for lifting, supporting or transporting people or for lifting or supporting loads over people.

Equipment described herein should not be used in conjunction with other equipment unless necessary and/or required safety devices applicable to the system, crane or application are installed by the system designer, system manufacturer, crane manufacturer, installer or user.

Modifications to upgrade, re-rate or otherwise alter this equipment shall be authorized only by the original equipment manufacturer.

If a below-the-hook lifting device or sling is used with a hoist, refer to ANSI/ASME B30.9, Safety Standard for Slings or ANSI/ASME B30.20, Safety Standard for Below-the-Hook Lifting Devices.

DANGER

Hazardous electrical power is present in the end truck motor, the supply of electrical power to the end truck motor and in the connections between components.

Before performing any maintenance on the equipment, de-energize the electrical supply to the equipment, and lock and tag the supply device in the de-energized position. Refer to ANSI Z244.1 – Personnel Protection- Lockout/Tag out of Energy Sources.

NOTICE

It is the responsibility of the owner/user to install, inspect, test, maintain and operate the equipment covered by this manual in accordance with ANSISME B30 volume(s) and OSHA Regulations.

It is the responsibility of the owner/user to have all personnel that will install, inspect, test, maintain and operate the equipment covered by this manual read the contents of this manual and applicable portion of ANSI/ASME B30volume(s) and PHSA Regulations.

If the owner/user of the equipment covered by this manual requires additional information, or if any information in the manual is not clear, contact ACI Hoist & Crane. **DO NOT** install, inspect, test, maintain or operate this equipment unless this information is fully understood.

A regular schedule of the equipment in accordance with the requirements of ANSI/ASME B30 volume(s) should be established and records maintained.

1.0 GENERAL DESCRIPTION

3.1 End Trucks (Under-Running)

Under-Running end trucks are designed to operate on parallel American Standard or Wide Flange crane runway beams. Runway beams must be sufficiently strong enough to support the crane bridge, hoisting equipment and rated load. Runway beams must be in accordance with CMAA 74, latest edition, and lower flange track wheel surface must be free of distortion or imperfections that may cause a malfunction or damage to the crane wheels. The maximum gap between mating ends of runway beam sections must not exceed 1/16".

The Under-Running end trucks are rigid steel welded, reinforced at the axles and girder connection. Each end truck has a driver wheel and a trailer wheel, which run on the runway beams. The wheels are mounted on fixed axles and rotate on anti-friction bearings. The wheels are made of heat treated solid forged steel and rotate on two sealed lifetime lubricated ball bearings. The bridge is driven by a motor and gear case attached to each end truck. The motor drives a single wheel at each end truck through the gear case then through a drive pinion and geared wheel arrangement.

3.2 Model Numbering

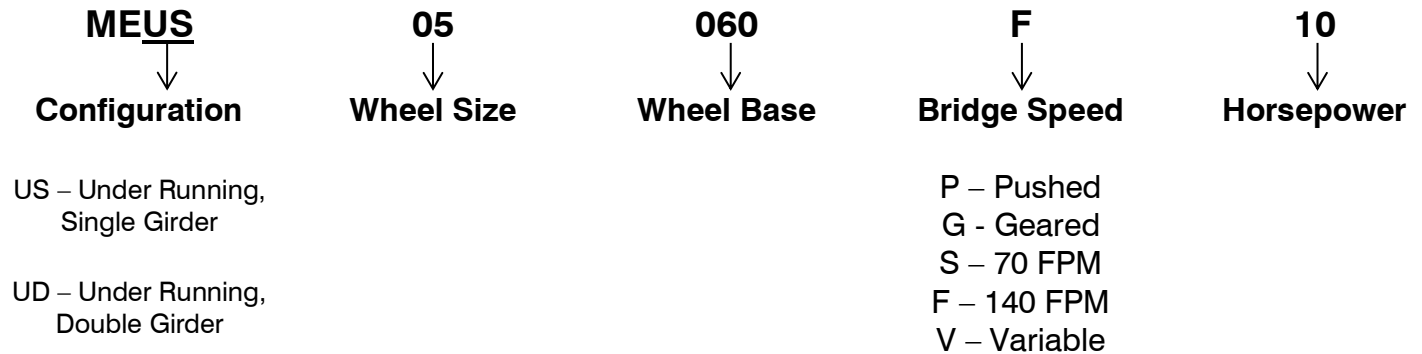

4.0 INSTALLATION

Installation must be performed by a qualified person in accordance with ACI Hoist & Crane. Severe injury, death and/or property damage can result if the end trucks are not correctly installed. For service in this area, please contact:

ACI Hoist & Crane
689 SW 7th Terrace
Dania, FL 33004
Phone: 954-367-6116
Fax: 954-272-0334
Toll Free: 1-866-424-6478
E-mail: info@acihoist.com

4.1 Prior to Installation

- Read and observe the instructions and warnings contained in this manual. Read and observe any instructions and warning tags attached to the crane.
- Check for any damage to the crane during shipment. **DO NOT** install a damaged crane.
- If a hoist is to be installed on the crane as part of the total installation, read and observe the instructions and warnings contained in the manual furnished with the hoist. Read and observe an instructions and warning tags attached to the hoist.
- Check that the monorail and other supporting structures where the crane will be installed has a load rating capable of handling loads equal to the rated load capacity of the crane.
- Check that runway stops are installed, or install runway stops at the open end or ends of the runway monorail to prevent the crane from traveling off the runway monorail beam. Runway stops that engage crane end truck wheels are not recommended. Check that runway stops will prevent overhanging parts of the crane and any hoist installed on the crane from interfering with other equipment beyond the ends of the runway monorail.
- Warning signs and barriers shall be utilized on the floor area beneath the runway where the crane will be installed.
- If the crane is to be installed on an existing runway and the crane runway remains energized because of other cranes operating on the same runway; stop or a signal person(s), located full time at a visual vantage point for observing the approach of an active crane(s), shall be provided to prohibit contact by the active crane(s) with the crane being installed and personnel involved in installing the crane.



The main switch (disconnect) supplying power to the runway shall be de-energized. Lock and tag the main switch in the de-energized position in accordance with ANSI Z244.1.



After the crane has been positioned on the runway and prior to connecting the crane to the runway electrification, the main switch (disconnect) supplying power to the runway shall be de-energized. Lock and tag the main switch in the de-energized position in accordance with ANSI Z244.1.

- If personnel will be required to work on the runway during installation, a guard or barrier shall be installed between adjacent runways for the length of the established work area to prevent contact between persons performing installation and a crane on the adjacent runway.
- If personnel are required to work at elevations in excess of 6 feet above floor or ground level, a fall prevention policy and procedure shall be developed, documented and implemented prior to installation being started.
- Check power supply that will be furnished to the crane. It must be same as shown on the crane serial plate. Standard crane drive single-speed motors are re-connectable for 230V or 460V, three-phase, 60Hz. Such motors and control will be connected at the factory for 460V unless otherwise specified.
- Check conductors supplying power to the crane and associated equipment to be sized to maintain the operating voltage at the crane at plus or minus 5% of the nominal operating voltage at all times. Standard nominal operating voltages are 208, 230, 240, 460, 480 and 575 volts.
- Check conductors supplying power to the crane and associated equipment to be protected against short circuit and overcurrent conditions in compliance with ANSI/NFPA 70, National Electrical Code. These requirements are listed in Article 610 and are the responsibility of the owner/user. It is also the responsibility of the owner/user to ensure that all protective devices and associated wiring comply with applicable Federal, State and Local Codes.
- Check and confirm that all crane components and items have been received. If any items are missing, contact ACI Hoist & Crane or the distributor of the crane.
- Place crane or crane components in correct position directly below the crane runway. Verify that crane electrification and runway electrification are properly positioned.
- Check that runway centers and crane span are correct. Determine orientation of crane position with respect to the runway.
- Rotate all end truck wheels by hand to check for possible damage during shipment.
- Ensure the crane motors are undamaged. All terminal nuts and screws, whether used or not, shall be correctly tightened. Supply connections shall be made with ring type terminal lugs which have insulated shanks. Make sure that clearance and distance are not reduced when tightening connections. Check that there are no loose conductor strands on any terminal. Check that the drain plugs are replaced after use and sealed with an appropriate sealing compound. Check that the brass terminal links are connected correctly so as not to reduce the clearance distance.
- Slowly rotate the motor shaft to ensure free movement. Ensure nameplate data on the motor corresponds with the requirements.
- Ensure the mounting/shaft orientation design and drain hole positions are correct for the application.
- Check for rough bearings, loose bearings and loose axles. Eyebolt(s) and any other lifting means must be tightened before using the motors.
- **DO NOT** install a damaged crane.

4.2 Installing Bridge Crane

The installation of the crane on the runway shall be performed only by a qualified person.

For information regarding attaching, lifting and moving the loads during installation, refer to ANSI B30.2 latest edition, ANSI B30.17 latest edition and other applicable codes.

⚠ DANGER

Before installing the crane on the runway, the main switch (disconnect) supplying power to the runway shall be de-energized. Lock and tag the main switch in the de-energized position in accordance with ANSI Z244.1.

4.2.1 Installing Under-Running Bridge Crane

Under-Running bridge cranes are usually lifted into position on the runway rails in one piece. Total weight of this crane should be checked against lifting equipment selected for erection of the crane.

Immediately after the crane is placed on the runway rails check the wheel flange clearances to the rail. Clearance between the side of the rail head and inside flange of the wheel should be between 3/4" and 1-1/8" depending on the wheel and rail combination and whether or not the truck is centered on the rail.

- **Open End Runway:** If one end of the crane runway is open and no interference is encountered the bridge crane can be placed on the end of the runway. First recheck the distance between the wheels. The distance between the inside faces of the wheel flanges should be the width of the bottom of the runway beam plus 1/4".
- **Removable Runway Section:** In some installations a removable runway section may be available. If so remove runway section, install bridge crane and reinstall the runway section.
- **Wheel Adjustment:** One of the ACI's unique end truck features is the ability to install the bridge crane in the center of the runway. This means that there is no requirement to remove a section of the runway to install the crane. Refer to Figure 4.2.1.1 below and follow these steps to adjust the wheels:

Step 1 – Remove all 4 rail sweeps.

Step 2 – Use wheel adjustment nuts to move the wheel as far apart as possible.

Step 3 – Measure clearance distance between the face of the wheels. This should be at least 1/4" wider than the beam flange width.

Step 4 – Lift crane into position.

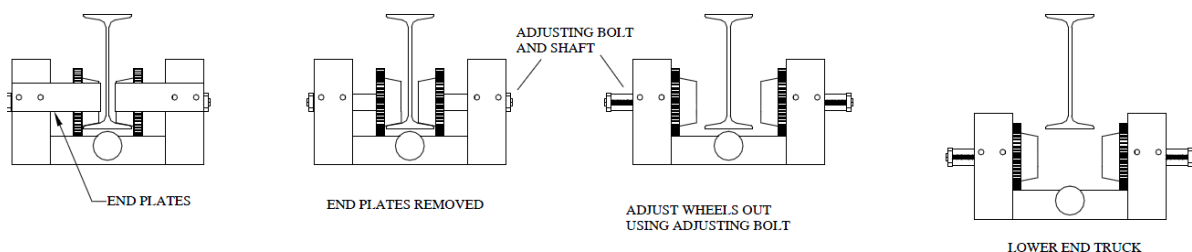

Figure 4.2.1.1

Step 5 – Adjust wheels per Figure 4.2.1.2

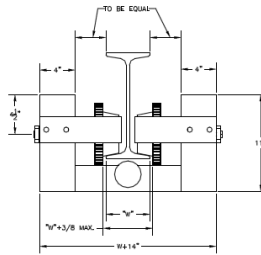

Figure 4.2.1.2

Step 6 – Reinstall rail sweeps.

NOTICE

It is suggested that the trolley and hoist be installed on the crane bridge at this time so that all wiring connections may be completed.

4.3 Connecting Power Supply to Crane

⚠ DANGER

Disconnect power and lockout disconnecting means before connecting power supply to crane.

Only a qualified electrician should connect the power supply to the crane.

Check power supply that will be furnished to the crane. It must be the same as shown on the crane serial number plate. If the power supply that will be connected to the crane is not the same as shown on the crane serial number plate, **DO NOT** connect power supply to crane.

Make all electrical connections in accordance with wiring diagram located in the control enclosure.

4.3.1 Runway Conductors

Motorized bridge cranes and bridge cranes equipped with a motorized trolley or power-operated hoist require runway conductors. When you are installing the conductor, follow the manufacturer's instructions and adhere to National, State and Local Codes.

⚠ DANGER

Before attempting any electrical connections, the main power switch feeding the runway conductors must be locked in the open (off) position.

4.3.2 Main Collectors

Install, adjust and align collectors with runway conductors. Connect collectors in accordance with wiring diagram.

4.3.3 Cross Conductors

In most cases, the cross conductors will be installed on the crane as received; however, if the conductors have been separately shipped, be certain that the instructions covering installation of these conductors is carefully followed.

Connect all wiring on the crane (main collectors to bridge panel, bridge panel to cross conductors and bridge panel to bridge motor).

4.3.4 Trolley Collectors

Electrically operated hoist and/or trolley require trolley collectors. Install collectors as shown in instructions furnished with the hoist and trolley. Connect wiring as shown on the crane wiring diagram.

4.3.5 Motor

Wiring of the motor and its controller, overload protection and grounding should be in accordance with the current edition of the wiring regulation and all local safety requirements.

Refer to the nameplate voltage and frequency to ensure the motor is correct for the power supply to which it is to be connected. Unless specified otherwise the motor may be assumed to be suitable for the nameplate voltage $\pm 5\%$ and nameplate frequency $\pm 1\%$.

Connection diagrams for the motor are generally supplied with it, either on the nameplate fixed to the motor or placed in the terminal box.

4.4 Outdoor Installation

For crane system installations that are outdoors, the end trucks should be protected from the weather when not in use.

In order to prevent internal corrosion from occurring, the end trucks may require lubrication more often than once or twice per year.

5.0 OPERATION

Operation of a top running crane usually includes the operation of an overhead hoist. Information in this section addresses both the crane and hoist; however, the operation section of the manual furnished with the hoist must be reviewed for specific operation procedures that apply to the hoist.

Operation of an overhead hoist and crane involves more than activating the buttons or levers of the hoist and crane control devices. It is emphasized in the ASME B30 Standards that the use of overhead hoists and cranes are subject to certain hazards that cannot be met by mechanical means, but only by exercise of intelligence, care, common sense and experience in anticipating the motions that will occur as a result of activating the hoist or crane controls. Certain precautions are necessary before moving the load and this includes the proper rigging of loads to the hoist hook.

5.1 Before Operating the Crane for First Time

Before energizing the power supply and inspecting and testing the crane prior to initial operational use, check that all electrical connections are in accordance with the wiring diagram located in the crane control enclosure.

- A. Check the main collector system for proper adjustment to maintain proper contact with conductor.
- B. Check along runway for possible interference if power is cable reel or festooned cable.
- C. Check the cross conductors and collectors for adjustment and proper tracking.

ASME B30 requires that all new, altered or modified cranes be inspected by a designated person prior to initial use to verify that the equipment and installation comply with applicable provisions of the standard. Such an inspection should be performed at this time using ASME B30.2 for top running bridge, single or multiple girder, top running trolley hoist or ASME B30.17 for top running bridge, single girder, Underhung hoist as the basis for inspection procedures.

- Inspect the crane to make certain that all bolted connections and attachments are properly tightened and that all electrical connections are secure.
- The hoist/trolley unit should be checked thoroughly. Check to make sure that that trolley wheels have the proper clearance to the beam (girder) flange for freedom of operation. Make certain the trolley stops have been installed and that they are correctly located.
- Visually inspect the hoist for any type of deformation or damage. Visually inspect hooks for nicks, gouges, deformation of the throat opening, twisting and wear on saddle or load bearing point.
- For a single girder crane the trolley wheels and the flange surface of the crane beam girder on which the trolley wheels rolls should be free of paint to provide the proper electrical ground. If the environment in which the crane will operate is such as to impair the contact between the trolley wheel and the crane girder, an extra cross conductor and trolley collector should be provided for grounding purposes. This also applies for a trolley wheel and crane rail and to the bridge wheel and the runway rail.
- Replace warning label(s) if missing or illegible.
- If a trolley hoist is mounted on the crane, check that end stops are installed on all open ends of the bridge girder or girders. If end stops are not present on all open ends, **DO NOT** operate trolley hoist until end stops are installed.
- Check crane drive motor voltage matches with the nameplate voltage and frequency on the motor. Unless specified otherwise the motor may be assumed to be suitable for the nameplate voltage $\pm 5\%$ and nameplate frequency $\pm 1\%$.
- Energize the power supply to the crane.

- Check crane travel for correct crane motion direction (crane drive motor or motors are properly phased). Since motor rotation of a three-phase AC motor can be changed by reversing any two of the lines feeding power to the motor, the direction of crane motion must be checked to verify that it is correct in accordance with the crane control device markings. See section 5.1.1 Crane Drive Motor Phasing.
- When starting motor fully loaded, if it does not start quickly and run smoothly, switch off immediately and when rotation has stopped, isolate from the power supply and examine the assembly for mechanical faults or poor connections.
- If there is excessive vibration it could be caused by poorly aligned couplings, loose mounting bolts, lack of rigidity in the supports, transmitted vibration from adjacent machinery etc. excessive vibration can lead to motor damage, for instance to the bearings making them noisy and hence vibration should be minimized.
- Ensure the current drawn is commensurate with that shown on the nameplate and that the currents in each phase are similar.
- Operate crane in both travel directions, without load on the crane and stop motion to check operation of the crane drive motor brake. The crane should stop within a distance equal to 10% of the full load travel speed of the crane. If the crane does not stop within this distance, the crane drive motor brake requires adjustment.
- If travel limit switches are installed on the runway or bridge girders, operate the crane or trolley hoist to verify limit switch operation.
- Operate the crane, without a load on the crane, for the entire travel distance of the runway monorail to check that crane and trolley hoist do not interfere with any other items or pieces of equipment located in the path of travel,
- If crane has a trolley hoist, operate the trolley hoist without a load on the hoist hook for the entire travel distance of the trolley to check that trolley, hoist, load block and hook do not interfere with any other items or pieces of equipment located in the path of travel.
- If crane operates in a system with interlocks or transfer sections, operate crane or trolley through all such devices to verify alignment and operation.

5.1.1 Crane Drive Motor Phasing

Initially, run the motor unloaded and establish that the rotation is as required. To check that, momentarily activate one button or lever of the crane control device and observe the direction of crane motion. If direction of crane travel matches the direction marking of the crane control device button activated (example, crane travel direction is EAST when the crane EAST control device button is activated), the crane motor is properly phased. If the direction of the crane travel does not match with the direction marking of the crane control device button activated (example, crane travel direction is EAST when the crane WEST control device button is activated), the crane motor is improperly phased and must be corrected. **DO NOT** use crane until motor phasing is corrected.



DO NOT operate crane if direction of crane motion does not match with the direction marking on the crane control device button activated.



DO NOT attempt to correct an improperly phased crane by changing any wiring in the crane control device at the crane contactors or by changing the markings on the crane control device.

To correct crane motor phase:



1. Disconnect power and lockout disconnecting means before reconnecting (reversing) power lines to crane.

2. Only a qualified electrician should reconnect the power lines to the crane.
3. Interchange any two lines supplying power to the crane motor only. **DO NOT** reverse main power leads to the crane as this will also affect the phasing of other motors in the system (example, hoist motors).
4. Re-energize power supply to the crane.
5. Re-check the crane travel for correct crane motion. If direction of crane travel matches the direction marking of the crane control device button activated (example, crane travel direction is EAST when the crane EAST control device button is activated), the crane motor is properly phased. If the direction of the crane travel does not match with the direction marking of the crane control device button activated (example, crane travel direction is EAST when the crane WEST control device button is activated), the crane motor is improperly phased and must be corrected. **DO NOT** use crane until motor phasing is corrected.

5.2 Operational Test

All new, altered, reinstalled, modified or repaired cranes or cranes that have not been used within the preceding 12 months shall be tested by the owner/user before being placed in operational service. The operational test is performed without a load on the crane and includes:

- Operation of control devices.
- Lifting and lowering.
- Operation of trolley travel.
- Operation of crane travel.
- Operation and setting of devices for interlocking mechanisms, track switches, drop sections, lift sections, travel limit switches and end stops.

Operational test steps are as follows:

1. If the crane has a hoist, check hoist hook travel for correct hook motion (hoist motor is properly phased). To check hook motion direction and hoist motor phasing refer to the manual furnished with the hoist.



DO NOT operate the hoist if direction of hook motion does not match the direction marking on the hoist control device button activated.

WARNING

DO NOT attempt to correct an improperly phased hoist by changing any wiring in the hoist control device or at the hoist contactors, or by changing the markings on the hoist control device.

2. If the crane has a motorized trolley, check trolley travel for correct travel direction. Refer to the manual furnished with the trolley hoist for proper motor phasing and direction.

WARNING

DO NOT operate the trolley if direction of trolley motion does not match the direction marking on the hoist control device button activated.

WARNING

DO NOT attempt to correct an improperly phased trolley by changing any wiring in the trolley control device or at the trolley contactors, or by changing the markings on the trolley control device.

3. Check that the crane travel motion matches the direction marking of the crane control device button activated. Refer to section 5.1.1 for proper crane motor phasing.
4. Operate the hoist in the raising and lowering direction, without load on the hook and stop motion to check operation of the hoist motor brake. Refer to the manual furnished with the hoist for instructions on hoist motor brake test and hoist motor brake adjustment.
5. Check operation of hoist limit switches as outlined in the manual furnished with the hoist.

WARNING

Never operate hoist without the protection of properly functioning limit switches.

6. Operate crane in both travel directions, without load on the crane and stop motion to check operation of the crane drive motor brake. The crane should stop within a distance equal to 10% of the full load travel speed of the crane. If the crane does not stop within this distance, the crane drive motor brake requires adjustment.
7. Check the trolley motor brake function in accordance with the instructions in the manual furnished with the trolley hoist.
8. If travel limit switches are installed on the runway or bridge girders, operate the crane or trolley hoist to verify limit switch operation. Adjust as required.

WARNING

Never operate hoist without the protection of properly functioning travel limit switches.

DANGER

Disconnect power and lockout disconnecting means before adjusting limit switches. Limit switches should be adjusted using a continuity tester or other type of tester that will indicate open or closed circuits without the need of electrical power.

Only a qualified crane technician should adjust switches.

9. Operate the crane, without a load on the crane, for the entire travel distance of the runway monorail to check that crane and trolley hoist do not interfere with any other items or pieces of equipment located in the path of travel.
10. If crane has a trolley hoist, operate the trolley hoist without a load on the hoist hook for the entire travel distance of the trolley to check that the trolley, hoist, load block and hook do not interfere with any other items or pieces of equipment located in the path of travel.
11. If crane operates in a system with interlocks or transfer sections, operate crane or trolley through all such devices to verify alignment and operation. Adjust as required.

DANGER

Never operate crane without the protection of properly functioning locking and safety devices.

12. Crane is now ready to be load tested if required.

5.3 Load Test

Complete cranes must be load tested in accordance with ASME B30.17 for top running trolley hoist or B30.2 if the hoist is underhung. It is the responsibility of the owner/user to load test the crane or final lifting system in accordance with ASME B30.

A load test must be conducted for all new, altered, reinstalled, modified or repaired cranes before being placed in operational service.

The load test shall be conducted under the direction of a designated person and a record of the test shall be made. The test load applied to the crane shall not be less than 100% of the rated load capacity of the crane or greater than 125% of the rated load capacity of the crane. Functions to be performed during the load test include:

- Operation of control devices.
- Lifting and lowering of the load.
- Operation of the brakes.

Load test steps are as follows:

1. Attach test load to the hoist hook.
2. Before lifting the load, operate the hoist in the lifting direction to take any slack out of the hoist wire rope/chain.

3. Lift the load a few inches and stop the hoist. If brakes stop and hold the load, continue lifting and lowering the load several feet, stopping the hoist several times in each direction to check that the hoist braking system stops and holds the load.
4. If the hoist braking system stops and holds the load, the hoist operates in accordance with the control devices and no unusual sounds are present during operation, proceed with the test.
5. If the hoist braking system does not stop and hold the load, the hoist does not operate in accordance with the control devices or any unusual sounds are present during operation, corrective action must be taken. Refer to the manual furnished with the hoist.
6. Transport the test load by means of the trolley hoist or carrier the full travel length of the trolley or carrier on the bridge girder.
7. Transport the test load by means of the crane the full travel length of the runway, in one direction with the trolley or carrier as close to the extreme right-hand end of the crane bridge girder as practical and in the other direction with the trolley or carrier as close to the extreme left-hand end of the crane bridge girder as practical. When the cranes operate on more than two runways (multiple truck cranes), the crane shall transport the test load for the full travel length of the runway with the test load under each of the intermediate end trucks.

Upon completion of the operational and load tests the crane is ready to be released for operating purposes.

5.4 Safety Rules

Operating rules listed below are suggested guidelines to encourage safety and are not intended to take precedence over individual plant safety rules and regulations or rules set forth by various applicable codes.

- Crane and hoist operators shall be required to read the operation section of this manual, the warnings contained in this manual, instructions and warning labels on the crane, the operation section and warnings contained in the manual furnished with the hoist, instruction and warning labels on the hoist and operation sections of ASME B30.17, ASME B30.2 and ASME B30.16; and to be familiar with the crane and hoist and crane and hoist controls before being authorized to operate the crane and hoist or lifting system.
- Crane and hoist operators should be trained in proper rigging procedures to be followed in the attachment of loads to the hoist hook.
- Crane and hoist operators should be trained to be aware of potential malfunctions of the equipment that require adjustment or repair and to be instructed to stop operation if such malfunctions occur and to immediately advise their supervisor so corrective action may be taken.
- Crane and hoist operators shall know hand signals used for hoist and crane operations if a signal person is used in the operation and accept signals of only persons authorized to give hand signals EXCEPT to obey a stop signal regardless of whom gives it.
- Crane and hoist operators should have normal depth perception, field of vision, reaction time, manual dexterity and coordination.
- Crane and hoist operators should not be subject to seizures, loss of physical control, physical defects or emotional instability that could result in actions of the operator being a hazard to the operator or others.
- Crane and hoist operators should not operate a crane, hoist or lifting system when under the influence of alcohol, drugs or medication.
- Cranes and overhead hoists are intended only for vertical lifting service of freely suspended unguided loads. **DO NOT** use crane or hoist for loads that are not lifted vertically, loads that are not freely-suspended or loads that are guided.

WARNING

Bridge cranes are not designed nor intended to be used for support or transport of people or for transporting loads over people. Supporting or transporting loads over people may result in injury.

5.4.1 General DO's and DO NOT's

Safe operation of an overhead hoist is the operator's responsibility. Listed below are some basic rules that can make an operator aware of dangerous practices to avoid and precautions to take for his own safety and the safety of others. Observance of these rules in addition to frequent examinations and periodic inspection of the equipment may save injury to personnel and damage to the equipment.

NOTICE

See applicable National, State and Local Safety Codes and regulations for additional requirements relating to Safe Operating Practices, including ANSI B30.2 or ANSI B30.17-latest edition.

- **DO NOT** load bridge beyond rated capacity.
- **DO NOT** subject bridge to side loads.
- **DO NOT** stand or allow others to stand or get under any load the bridge is supporting.
- **DO NOT** attempt to operate bridge crane before completing tests and adjustments.
- **DO NOT** run the bridge into the end stops, other bridge or any obstruction on the beam. Improper and careless operation may result in a hazardous condition for operator and load.
- **DO NOT** operate the crane or hoist if any damage or malfunctions exist.
- **DO NOT** operate the crane or hoist if it is tagged with an out-of-order sign.
- **DO** center the trolley and hoist over the load when hoisting.
- **DO** keep clear and make sure others keep clear of any load the bridge is supporting.
- **DO** be sure the load is clear of obstruction before traversing the load.
- **DO** attach the load to the hoist hook by suitable means such as slings or lifting devices.
- If the bridge crane is mounted on an open-end runway rail, then end stops must be installed to prevent bridge crane from running off the end of the runway rail resulting in injury to the operator, others and damage to the load and/or other property. End stops for the trolley **MUST** be installed.
- Verify the size of the attachment of the sling or other lifting device to be used is compatible with the size of the hoist hook.
- Verify the attachment part of the sling or other lifting device is properly seated in the base, bowl or saddle of the hoist hook.

- Verify that the hook latch operates properly and that the hook latch properly bridges and closes the hook throat opening.
- Verify that the latch of the hoist hook will not support any part of the load.
- Verify that the load or any part of the load will not be applied to and/or not supported by the top or point of the hook.
- Verify that the load will be properly balanced when it is lifted.
- Verify that side loads will not be applied to the crane or hoist when the load is lifted.
- Notify personnel in the area that a load will be lifted and verify that all personnel are clear of the load.
- Verify that when the load is lifted it will clear all material, machinery or other obstructions in the area.
- Report any damage or malfunctions to the supervisor.

5.5 Operating Controls

After making certain the crane is completely and properly installed, with the crane connected to the electrical service and all the pre-operation checks made, the operator should learn the controls.

On cranes having any or all motions electrically operated, operator should locate the runway disconnect and make sure this switch is locked open (OFF). The operator should now operate the various push buttons to get the “feel” and determine that they do not bind or stick in any position. The operator should become familiar with the push button location for their respective motions as well as “start” and “stop” buttons (normally the top two buttons), which operate the crane main line contactor. The main line contactor will shut off power to all motions.



If any push button binds or sticks in any position. **DO NOT** turn the power on. Determine the cause of the malfunction and correct it before operating the crane.

5.5.1 Operating the Controls without a Load

STEP 1 – Close the crane runway disconnect switch.

STEP 2 – Close (POWER ON) the crane disconnect switch mounted on the crane. The crane main disconnect switch is located in the bridge panel and is operable from the front of the panel without opening the panel. The switch is operated by rotating the handle. The “OFF” and “ON” positions of the switch are marked on the switch assembly. The bridge control panel also contains a 3-pole mainline contactor. This contactor is connected in the electrical system on the load side of the crane main disconnect switch, so that all the crane power flows through this contactor. The mainline contactor is opened and closed (turned off and on) by means of the stop-start buttons on the pendant push button station. These stop-start circuits, as well as other control circuits, operate at 115 volts. This 115 volt control circuit voltage is obtained from a transformer mounted in the bridge control panel.

STEP 3 – Press the start push button which will close the mainline contactor, applying power to all control devices. The crane is now ready for further testing. When the bridge on this crane is powered by variable speed drives the slow speed is used for starting and for positioning. The fast speed is used for general bridge movement between two points. There is one button for each direction labeled bridge “FWD” and “REV”. Depressing either button slightly will cause the bridge to operate at slow speed. Further depression of the button will cause the bridge to run at fast speed.

WARNING

If any push button binds or sticks in any position. **DO NOT** turn the power on. Determine the cause of the malfunction and correct it before operating the crane.

STEP 4 – Momentarily depress bridge “FWD” button. Check to be certain both motors run in the same direction. Momentarily depress “REV” button. Motors running in the opposite direction will cause vibration and skewing of the bridge.

STEP 5 – To check that electrical connections have been properly made, operate bridge cautiously on runway. Watch for any obstructions or interferences between crane and building parts. Depress “FWD” button slightly - bridge will travel along runway without vibration or skewing when both motors are running at the same speed. If skewing is evident, stop bridge and recheck motor electrical connections.

STEP 6 – Operate the bridge from one end of the runway to the other checking for obstructions or interferences. Proceed with CAUTION and be prepared to stop short of any obstructions. If bridge power is interrupted during runway travel, check main collectors for proper contact with runway conductors.

WARNING

Lock the main runway disconnect switch in the open position (off) before attempting to adjust main collectors or conductors.

STEP 7 – After making certain that all building and structural clearances are adequate, practice going “FWD” and “REV” with push button depressed only slightly (slow speed). Note the stopping distance of the bridge at slow speed without load. Now depress “FWD” or “REV” further, causing the crane to run at faster speed. Again note the distance the crane requires stopping after releasing the push button.

After becoming familiar with these motions, the operator can now depress the hoist “Up” button. Depress the “Down” button. Practice moving the hook up and down.

WARNING

If, when depressing the hoist “UP” button, the hook lowers, **STOP AT ONCE, DO NOT** attempt to operate again. Report this condition to the proper supervisor for correction.

If using wire rope hoist the hook may be lowered until TWO FULL WRAPS of cable remain on the drum. Note the position of the hook and NEVER LOWER THE HOOK BELOW THIS POSITION. Some hoists may have a lower limit switch which will stop the hoist when this position is reached.

Depress the hoist “UP” button and slowly return the hook to near its high position. Continue to raise the hook by slow inching. CAREFULLY OBSERVE the relationship of the hook block and the bottom of the hoist frame. The hoist upper limit switch, when working properly, should cause the hoist up motion to stop and/or reverse direction.

WARNING

DO NOT contact or strike the hoist frame with the hook block. If the hoist motion is not interrupted by the limit switch, stop the hoist by removing your finger from the button and/or depressing the **STOP** button. **DO NOT** attempt further operation until the limit switch is operable.

NOTICE

Jogging is used excessively by some operators for making “inching” crane movements. Avoid excessive use of jogging since it may cause premature burning of contactor contact tips and motor overheating.

5.5.2 Operating the Controls with a Load

Make certain the hook is high enough to clear any obstruction below. Move the bridge to a position directly over the load and operate in the following sequence:

STEP 1 – Spot the trolley and hoist over the load. If control is suspended from the bridge, hand signals may be required from ONE authorized floor man at the load. Be certain the load to be lifted is properly rigged and does not exceed the rated capacity of the hoist, trolley or bridge.

STEP 2 – Slowly raise the hook until the slack has been taken out of the slings. When the floor man signals and the operator is satisfied the load is secure in the sling, lift the load slowly until clear. Now, hoisting speed can be increased and maintained until the load is clear of all obstructions or the floor man gives the signal to stop.

STEP 3 – Starting slowly and increase speed as distance permits moving the bridge toward the point where the load is to be lowered. Decelerate by holding the push button in the first step. Final spotting is accomplished by releasing the button to allow the bridge brake to stop the crane. The stopping distance will be greater than with no load on the hook.

STEP 4 – Learn to judge the stopping distance of the bridge and trolley, both with light and full loads. This will enable you to “spot” loads with the minimum amount of jogging.

NOTICE

Refer to hoist and trolley manuals for complete operating instructions for the hoist and trolley.

WARNING

DO NOT walk under a suspended load.

DO NOT perform any work on a suspended load that requires a worker to be positioned under the suspended load.

If it is essential that a worker be positioned under a suspended load to perform work on the suspended load; such work shall not be started or performed until other auxiliary supporting means are placed under the suspended load. Failure to use other auxiliary supporting means could result in serious bodily injury or death, and/or property damage.

5.5.3 Operating the Crane and Moving the Load

While operating the crane and moving the load, operator SHALL:

- **NOT** engage in any activity that will divert the attention of the operator.
- **NOT** lift, lower, or transport a load with the crane or hoist until the operator and all other personnel are clear of the load and the path of the load.
- Verify that the load, crane, and hoist will clear all obstacles before moving or rotating the load.
- Avoid moving loads over personnel.
- **NOT** lift, lower, or transport personnel by means of the crane, hoist, trolley, hoist hook, or load.
- Slowly inch the hook into engagement with the load to eliminate wire rope slack and reduce impact loading of the crane and hoist.
- Avoid unnecessary inching and quick reversals of direction.
- Only lift the load a few inches to verify that the load is properly balanced before continuing with the lift.
- Only lift the load a few inches to verify that the hoist braking system is functioning properly before continuing with the lift.
- Only traverse the load a few inches to verify that the crane braking system is functioning properly before continuing with travel.
- Avoid swinging of the load or hoist hook when the crane and/or hoist is traveling.
- Avoid sharp contact between trolleys or between trolleys and stops.
- Avoid sharp contact between cranes or between cranes and stops.

5.5.4 Parking the Load

The operator SHALL:

- **NOT** lower a load with the hoist until the operator and all other personnel are clear of the load and the path of the load.
- Verify that the load will clear all obstacles before lowering the load.
- Block loads before landing if slings or other lifting devices must be removed from under the landed load.
- Exercise care when removing a sling from under a landed and blocked load.
- **NOT** leave a suspended load unattended unless specific precautions to prevent the load from inadvertent lowering have been instituted and are in place.
- Position the hoist load block and hook above head level for storage when the hoist is not in use.

6.0 INSPECTION

Cranes shall be maintained, inspected, and tested in accordance with the MAINTENANCE AND REPAIR, INSPECTION, and TEST sections of this manual and in accordance with the intervals and requirements of ASME B30.2/ B30.17. Hoists shall be maintained, inspected, and tested in accordance with the manual furnished by the hoist manufacturer and in accordance with the intervals and requirements of ASME B30.16.

6.1 Prior to Inspection

Before maintenance or inspections are performed on a hoist, trolley, crane, crane runway, crane runway or monorail support, or crane runway or monorail conductors, the following precautions shall be taken as applicable.

- The hoist, trolley, or crane to be inspected, tested, or repaired shall be run to a location where it will cause the least interference with other hoists, cranes, and operations in the area.
- If a load is attached to the crane, it shall be landed.
- All controllers shall be placed in the off position.
- If a trolley hoist is installed on the crane, the trolley shall be blocked to prevent trolley movement.
- The crane shall be blocked to prevent crane movement.
- Warning signs and barriers shall be utilized on the floor beneath the hoist, crane, or lifting system where overhead maintenance, repair, or inspection work creates a hazardous area on the floor beneath the hoist, crane, or lifting system.
- If the crane runway remains energized because other cranes on the same runway are in operation, rail stops or a signal person(s), located full-time at a visual vantage point for observing the approach of an active crane(s), shall be provided to prohibit contact by the active crane(s) with the idle crane; with persons performing maintenance, repair, or inspection; and with equipment used in performing the maintenance, repair, or inspection.
- A guard or barrier shall be installed between adjacent runways for the length of the established work area to prevent contact between persons performing maintenance, repair, or inspection and a crane on the adjacent runway.
- Safe access to the hoist, crane, or lifting system, such as scaffolding, work platforms, etc., shall be provided for personnel that will perform maintenance, repair, or inspection. If personnel are required to work at elevations in excess of 6 feet above floor or ground level, a fall prevention policy and procedure shall be developed, documented and implemented by the owner/user.

6.1.1 Lockout/Tagout Procedures

When performing inspection, maintenance or repair work on ACI Hoist & Crane equipment, always follow lockout/tagout procedures as required by OSHA 29 CFR Part 1910.147. Lockout/tagout procedures are intended to protect personnel working on or around the equipment by preventing accidental start up or exposure to hazardous energy release such as electrical shocks. Lockout/tagout is the placement of a lock/tag on the energy isolating device in accordance with an established procedure. The procedure requires that individual locks or tags are placed on controls, shutoff switches, valves or other devices to prevent usage until the person who installed the lock or tag removes it. Never attempt to operate any control, switch, valve or other device when it is locked or tagged out.

OSHA required lockout/tagout procedures include:

1. A documented and established site policy on the steps to follow for lockout and tagout such as:
 - Notify all affected people including supervisors before lockout or tagout is used.
 - Shut off the affected machine, equipment, system or function.
 - Disengage, isolate or release energy supply or source.
 - Apply individual locks and/or tags on controls, switches, valves or other devices to prevent usage.
 - Try or test the machine, equipment or system to check that all the energy has been removed before service or maintenance.
2. Employee training about the facility's lockout/tagout procedures.
3. Identification and location of shutoff switches, controls, valves or other devices that isolate hazardous energy are predetermined at the site facilities.
4. After maintenance, repair, or inspection work is completed, and before the hoist, crane, or lifting system is returned to normal operation:
 - Lock and tag on the main switch (disconnect) of the hoist, crane, or lifting device shall be removed only by the person that locked and tagged the main switch originally, or an authorized person.
 - Warning signs, barriers, and guards shall be removed only by authorized personnel.
 - Any guards on the hoist, crane, or lifting system that were removed to perform maintenance, repair, or inspection work shall be reinstalled.
 - Any safety devices on the hoist, crane, or lifting system that were deactivated to perform maintenance, repair, or inspection work shall be reactivated.
 - Any parts that were replaced and other loose material shall be removed.
 - All equipment used in the maintenance, repair, or inspection work shall be removed.
5. After maintenance and service is finished and each lock and/or tag has been removed by the appropriate individual and all affected people are notified then restore energy or power.

6.2 Inspection Procedure

Crane shall be maintained, inspected, and tested in accordance with the manual furnished by the crane manufacturer and in accordance with the intervals and requirements of ASME B30.17/ ASME B.30.2.

Regular in-service inspection and preventative maintenance programs not only help reduce overall maintenance costs but may also prevent service shutdowns by forewarning of problems that could cause these shutdowns. Regular inspections, periodic minor adjustments, regular cleaning and lubrication and replacement of worn parts can help preserve good performance and operation of the crane.

Many factors influence the inspection and preventative maintenance program required for the crane and hoist. Frequency and severity of service and material handled, local environmental conditions and various applicable codes are some of the factors that the user must consider to adjust inspection and maintenance program outlined in this section to meet the specific conditions.

Inspection procedure for cranes in regular service is divided into two general classifications as outlined in ASME B30. These two general classifications are based upon the intervals at which inspections should be performed. The intervals are dependent upon the nature of the critical components of the crane, and the degree of exposure of crane components and parts to wear and deterioration. The degree of exposure is dependent upon crane activity, and severity of crane service. Environmental conditions in which the crane operates are also important considerations for the user, when adjusting crane inspection and maintenance programs to local conditions. Frequency of inspection and maintenance must be increased if hoist and crane are subjected to severe atmospheric environmental conditions, such as corrosive vapors, extreme heat or cold, cement or dust and other airborne contaminants. The user should carefully consider all environmental conditions and adjust frequency and degree of maintenance for the local conditions. Various codes also regulate inspection and maintenance programs. Attention must be given to applicable federal standards, OSHA regulations, national standards, state and local codes which may include mandatory rules relating to hoist and crane inspection and maintenance. The user should become familiar with all applicable codes for the area and be guided accordingly.

These two general classifications of crane inspections are designated as **Frequent** and **Periodic**. In addition, daily inspections are required to be performed by the operator at the start of each shift, or at the time the hoist is first used during each shift.

6.2.1 Service & Frequency Information

Definitions of service from ASME B30.17 are as follows:

- Normal Service – Service which involves operation of the crane with randomly distributed loads within the rated load limit, or uniform loads less than 65% of rated load, for not more than 25% of the time for a single work shift.
- Heavy Service – Service which involves operation within the rated load limit which exceeds normal service.
- Severe Service – Service which involves normal to heavy service with abnormal operating conditions.

FREQUENT INSPECTION: Frequent inspections are visual inspections and examinations by the operator or other designated personnel with records not required. Nominal inspection intervals are as follows:

Normal service – monthly

Heavy service – weekly to monthly

Severe service – daily to weekly

PERIODIC INSPECTION: Periodic inspections are visual and audio inspections and examinations by designated personnel making records of external conditions to provide the basis for a continuing evaluation of the crane and components. If the external inspection indicates the need, some disassembly may be required to make a more detailed inspection and examination. Nominal inspection intervals are as follows:

Normal service - annually

Heavy service - semiannually

Severe service – quarterly

The inspection and maintenance intervals outlined in this section are considered a minimum. Recommended in the schedule are minimum inspection and maintenance intervals based on average daily use in a normal environment.

6.3 Daily Inspection

Required daily inspection items to be performed by the operator at the start of each shift, or at the time the cranes first used during each shift are shown in Table 6.3.1.

Table 6.3.1
Daily Inspection

Item	Inspection Points
Tagged Crane	Check that crane is not tagged with an out-of-order sign.
Control Devices	Check that travel motions match the control device markings.
Brakes	Check that crane travel motions do not have excessive drift.
Oil Leakage	Check for any sign of oil leakage on the crane and on the floor area beneath the crane.
Unusual Sounds	Check for any unusual sounds from the crane and crane mechanism while operating the crane.
Warning Label	Check that warning label is not missing and that it is legible.

If a hoist is installed on the crane, refer to the manual furnished with the hoist and ASME B30.16 to determine the daily inspection items that must be performed by the operator.

If any damage or malfunctions are noted by the daily inspection items of Table 1, the operator shall not operate the crane, and shall immediately advise the supervisor so corrective action can be taken. If the crane is tagged with an OUT-OF-ORDER sign, the operator shall not operate the crane. Crane operators should be trained to be aware of malfunctions of the equipment during operation, and to immediately stop operation if such malfunctions occur, and to immediately advise the supervisor so corrective action can be taken.

6.4 Frequent Inspection

Inspection should be made on a frequent basis in accordance with Table 6.4.1 “Frequent Inspection”. Included in these frequent inspections are observations made during operation for any defects or damage that might appear between periodic inspections. Evaluation and resolution of the results of frequent inspections shall be made a designated person such that the crane is maintained in safe working condition.

Table 6.4.1
Frequent Inspection

Item	Inspection Points
All Functional Operating Mechanisms	For proper operation, proper adjustment, and unusual sounds.
Hoist(s)	In accordance with ANSI/ASME B30.16.
Upper Limit Devices	In accordance with ANSI/ASME B30.16.
Hook(s) and hook latches	In accordance with ANSI/ASME B30.10.
Control Devices	Improper operation.
Warning Label(s)	Missing or illegible.
Control Device Markings	Missing or illegible.
Lubricant Levels	Lubricant must be added or replaced.

If a hoist is installed on the crane, refer to the manual furnished with the hoist and ASME B30.16 to determine the frequent inspection items that must be performed. If any damage or malfunctions are noted by the Frequent Inspection items of Table 6.4.1, the crane shall be tagged with an OUT-OF-ORDER sign and shall not be returned to regular operation until maintenance and repair of the damage or deficiencies found during the inspection have been corrected.

6.5 Periodic Inspection

Inspection should be made on periodic basis in accordance with Table 6.5.1 “Periodic Inspections”. Evaluations and the result of periodic inspection shall be made by a certified person such that the crane is maintained in safe working condition. For inspection where load suspension parts of the hoists are disassembled, a load test per ANSI/ASME B30.16 must be performed on the hoist after it is re-assembled and prior to its return to service.

Table 6.5.1
Periodic Inspection

Item	Inspection Points
All Functional Operating Mechanisms	For proper operation, proper adjustment, and unusual sounds.
Hoist(s)	In accordance with ANSI/ASME B30.16.
Upper Limit Devices	In accordance with ANSI/ASME B30.16.
Hook(s) and hook latches	In accordance with ANSI/ASME B30.10.
Control Devices	Improper operation.
Warning Label(s)	Missing or illegible.
Control Device Markings	Missing or illegible.
Lubricant Levels	Lubricant must be added or replaced.
Fastening Devices	Loose or missing bolts, nuts, pins or rivets.
Crane Drive Motor Brake	Drift and excessive wear.
Supporting Structure	Cracks, damage and distortion.
End Trucks	Cracks, damage and distortion.
Trolley	Cracks, damage and distortion.
Crane and Trolley Wheels	Flat spots, damage and excessive wear.
End Truck Washers	Cracks, excessive wear and dirty lubricant.
Electrical Apparatus	Pitting, deterioration and wear.
Contactors	Pitting, deterioration, wear and improper operation.
Wiring and Fittings	Loose connections, abraded, cut or nicked insulation.

If any damage or malfunctions are noted by the periodic inspection items of Table 6.5.1, the crane shall be tagged with an OUT-OF-ORDER sign and shall not be returned to regular operation until maintenance and repair of the damage or deficiencies found during the inspection have been corrected.

Records of the condition of critical components such as wheels and brakes observed during frequent and periodic inspections should be established. This record should also record replacement, maintenance, and repair information. Use of this recorded information will allow a preventative maintenance program to be established for replacement of wearing components on a regular basis, thereby eliminating or reducing unscheduled downtime situations.

6.6 Occasionally Used Cranes

A crane that is not in regular service, that has been idle for a period of one month or more, but less than one year, shall be inspected in accordance with the requirements for frequent inspection before being placed into service.

A crane that is not in regular service, that has been idle for a period of one year or more, shall be inspected in accordance with the requirements for periodic inspection before being placed into service.

6.7 Inspection Report & Criteria

This section covers inspection of specific items. In accordance with ANSI/ASME B30, these inspections are not intended to involve disassembly of the crane. Rather, disassembly for further inspection would be required if frequent or periodic inspection results so indicate. Such disassembly and further inspection should only be performed by a certified person trained in disassembly and re-assembly of the crane.

Table 6.7.1
Inspection Methods & Criteria

Crane Component	Part of Component	Item	Method	Criteria	Corrective Action
Crane Electric Parts	Power Supply	Guide wire tension	Visually.	The wire must be sufficiently tight to minimize sag.	Tighten.
		Cable hanger installation and mobility	Visually.	The cable must be hung from cable hangers at even intervals. The cable must be hung from the cable hangers so that it does not twist.	Replace hangers.
		Cable length	Visually.	The cable must be 10% longer than the crane's maximum travel distance.	Replace cable with a longer one.
	Ground Protection	Ground connection points	Verify non-current carrying parts are grounded.	Non-current carrying parts must be grounded and must not exceed 100Ω resistance to ground. Travel surfaces must be kept clean and free of insulating materials such as paint, oil or grease.	Ground parts to conform to applicable standards and regulations. Remove any insulating materials.
	Insulation	Wiring	Use insulation resistance meter to check wiring integrity.	Insulation resistance must be 0.5 MΩ or more.	Replace wires/cables that have defective insulation.
Travel Rail / Runway	Travel Rail / Runway	Looseness in fasteners	Check tightness or torque.	Fasteners must be sufficiently tight.	Tighten.
		Oil, grease or paint on traveling surfaces	Visually.	The traveling surfaces must be free of oil, grease or paint.	Clean.
		Rail/Runway dimensions	Measure.	Dimensions to be in accordance with CMAA criteria.	Adjust as necessary to meet the criteria
Girder (Bridge Beam)	Bridge Beam	Bridge beam	Visually and Measure.	The beam must not be deformed or damaged. Travel surface must not be worn excessively.	Repair or replace parts.
		Welded parts	Visually and NDT if necessary.	Welds to be in accordance with CMAA criteria.	Repair.
		Looseness in fasteners	Check tightness or torque.	Fasteners must be sufficiently tight.	Tighten.
		Deflection	Measure under a rated load at mid span.	Deflection must be within 1/600 or less of span.	Repair, replace or lower the rated capacity.

Table 6.7.1
Inspection Methods & Criteria (cont'd)

Crane Component	Part of Component	Item	Method	Criteria	Corrective Action
End Trucks	Wheels	Track wheel	Measure.	Diameter must not be worn more than 5% of rated diameter. The diameter of the drive wheels on the left end truck must not be different from the diameter of the wheels on the right end truck by more than 1%.	Replace.
		Track wheel geared teeth (Geared/Motorized)	Visually.	Teeth should not be cracked, damaged or excessively worn.	Replace.
	End Trucks	Missing or incorrectly positioned snap rings	Visually.	No snap rings may be missing or out of position.	Replace or re-install.
		Lubrication	Visually.	The track wheel teeth and teeth of the pinion must be sufficiently lubricated.	Grease.
		Bolts/fasteners	Check tightness or torque.	Bolts and fasteners must be sufficiently tight.	Tighten.
	Gear Motor	Bolts/fasteners	Check tightness or torque.	Bolts and fasteners must be sufficiently tight.	Tighten.
		Outer appearance	Visually.	No cracks or other damagers should be detected.	Replace parts.
		Damage to bearings	Try turning by hand.	Bearings should turn smoothly.	Replace parts.
		Braking	Start and stop the crane.	The crane must come to a smooth stop within 10% of its traveling speed when the brakes are applied.	Adjust the left and right motor brakes.
		Lubrication	Overhaul and check visually. Refer to "Maintenance and Repair".	Parts must be sufficiently lubricated. Lubricated parts must not be overly dirty or contaminated with foreign matter.	Grease or degrease. Replace or clean parts.

6.8 End Tuck and Wheel Inspection

Crane end trucks and wheels should be inspected every three months, and during scheduled frequent and periodic inspections, as follows:

- Inspect crane wheel bearings for wear by manually rotating and rocking wheels. If excessive bearing play is present, replace bearings.
- Inspect for wear, flat spots, or damage to wheel tread; and cracked or broken wheel flanges. Replace wheels as required. When wheel replacement is required, all the wheels of a crane should be replaced.

- Inspect gear teeth of geared wheels and pinion for wear, cracks, or damage. Replace geared wheels or pinion as required. Geared wheels should always be replaced in pairs.
- Inspect and tighten or replace as required all bolts, nuts, and locking devices on the end truck.
- Inspect and tighten or replace as required all bolts, nuts, and locking devices connecting bridge girder or girders, trusses, braces, and other structural members to the end trucks.
- Check lubrication in accordance with the LUBRICATION section of this manual.

6.9 End Truck Motor

Gear motor is a 3-phase Squirrel-Cage Motor type. An AC gear motor consists of a rotor winding in the stator section and an integral gearbox or gear head. The changing field caused by 60 Hertz AC line voltage causes the rotor to rotate about the axis of the motor. AC motors are the most common and simple type of motor manufactured.

Standard crane drive single-speed motors are re-connectable for 240 volt or 480 volt, three-phase, 60 Hz. Such motors and control will be connected at the factory for 480 volt unless otherwise specified. Inspect the motor at regular intervals. Ensure it is kept clean with clear ventilation openings. Excessive vibration and noise emitted from the motor is not normal. Ensure fixings and fasteners have not loosened. Ensure also that electrical connections are tight and not corroded and grounding is intact.

Inspect shaft seals and terminal box gaskets to ensure they are in position and not significantly worn. Examine the paint finish and repaint if necessary to avoid excessive corrosion. Ensure that shaft couplings are fixed firmly and that shaft alignment is correct. Ensure also that there is no buildup of liquid inside the motor that would adversely affect its performance and drain if there is.

7.0 MAINTENANCE & REPAIR

Maintenance services required on top running cranes are, for the most part, simple periodic inspections and adjustments. If maintenance, adjustment, replacement of parts, or repair of the crane is required because of any damage or malfunctions noted during the daily, frequent, or periodic inspections outlined in the INSPECTION section of this manual; because of conditions found during a crane test as outlined in the OPERATION section of this manual; or based upon specific instructions outlined in other sections of this manual; the crane shall be taken out of service, and maintenance performed as required.



Hazardous voltages are present in the motorized end truck, the control box, other electrical components and connections between these components.

Before performing any maintenance on the equipment, de-energize the electrical supply to the equipment, and lock and tag the supply device in the de-energized position. Refer to ANSI Z244.1.

7.1 Lubrication

All moving parts of the crane for which lubrication is specified should be inspected, checked, and lubricated on a regular basis. The method used to deliver lubricant should be checked for proper delivery of the lubricant. If a hoist is installed as part of a crane or lifting system, lubrication instructions covered in the manual furnished with the hoist should be followed.

Crane machinery shall be stationary when inspecting, checking, adding or changing lubricants. The main switch (disconnect) of the crane, or lifting system shall be de-energized. Lock and tag the main switch in the de-energized position in accordance with ANSI Z244.1.

7.1.1 Detailed Lubrication Requirements

- Wheel bearings are permanently lubricated and require no additional lubricant.
- Drive wheel gears are to be lubricated with an open type gear grease which is heavy, plastic, extreme pressure and tacky; such as MOBIL 375 NC or equal.
- Crane drive unit gear housings are enclosed (Fig. 3) and provide a liberal oil reservoir from which gears and bearings inside the housing are splash-lubricated. After initial 1000 hours of usage, the interior of the reducing gear should be cleaned up and refilled with new oil. For moderate usage, the gear case lubricant should be changed after 2000 operational hours or every year, whichever comes first. The lubricant should be changed more frequently if the service is more severe. Use synthetic gear oil, AGMA lubricant number 7, compounded, (Mobil Gear 634 or equal) for the ambient temperature between 50° to 125° F. If the gear reducer will be used in special conditions, such as high speed, high temperature, low speed, heavy load, and forced lubrication contact manufacturer. Insufficient lubricant oil may lead to the rapid wears of worm gear and low efficiency while excessive of lubricant oil may lead to oil leakage. Lubricants to be used for the maintenance of the end truck are listed in the Table 7.1.1.1

Table 7.1.1.1
Lubricants

Location	Manufacturer & Type	Quantity
Reduction Gear	MOBIL oil SHC 634	260 cc
Drive Wheel Gear	MOBIL 375 NC or equivalent	Sufficiently lubricate

7.2 Wheel Removal

To remove the wheels follow the steps below:

1. Remove any load from the hook and move the trolley to the opposite end of the bridge.



Injury to personnel and/or damage to equipment can occur when truck wheel is removed if proper instructions are not followed.

Make sure that the truck is adequately supported so that it cannot drop when the wheel is removed.

2. Remove load from wheel. This can be accomplished by jacking a very small distance.
3. Remove the snap ring from the shaft.
4. The wheel shaft is held in position by a flat washer and nut on the adjustment bolt. Removal of this bolt allows removal of the axle.
5. Pull the axle toward the center of the crane. Completely remove the axle from the truck and store in a safe place.
6. The wheel is now free. Attach sling and lift wheel.
7. The bearings are held by internal snap rings. It is necessary to remove these snap rings for bearing removal.
8. The wheel axle is held in position by an axle keeper plate which is fastened to the truck weldment by two socket head cap screws with lock washers. Removal of these screws allows removal of the axle key. The axle key fits into a milled area of the gear wheel axle. Removal of the axle key allows removal of the axle.
9. Replace wheels in reverse order of disassembly. It is recommended that the bearings be replaced when replacing wheels.

7.3 Gear Motor

DO NOT disassemble the motor itself. It is recommended that if any work is required, the motor should be returned to the crane builder. For hoist and trolley motors, consult the hoist and trolley literature.

7.4 Storage

Whenever end trucks are to be placed into storage, place extra grease onto all exposed unpainted areas such as wheels, gears, collars and splines. Make certain that no debris, dirt or moisture is allowed to accumulate on the end truck during preparations for storage. The storage location should be clean and dry.

7.4.1 For Long Term Storage and Humid Environments

If the motor has been stored for an extensive period or subjected to adverse moisture conditions, ensure the insulation resistance is greater than 1M Ohm before switching on. Also, re-grease the bearings and if they are rusty, replace them.

If the insulation resistance is not greater than 1 M Ohm, dry out the motor as described below. If after drying out the insulation resistance is still not greater than 1 M Ohm, the motor will need repairing.

- Place motor on a high and dry location that is well-ventilated without direct sun, dust or corrosive gas.
- It should not be located near a boiler or freezer.
- It should be entirely free from vibration and movements.
- Motors should be put on pallets to prevent moisture.

7.4.2 Drying Out a Motor

This may be carried out by either:

- Baking in an oven at up to 194°F. Ensure the interior and exterior of the oven are well ventilated.
- By locking the rotor so it cannot move and connecting a low voltage to the motor windings. Gradually increase the voltage from zero until the current is about one third the rating plate value. Trim the voltage as necessary so that the winding temperature remains below 194°F.

Drying is complete when the insulation resistance stops changing.

8.0 TROUBLESHOOTING

If crane operates erratically, or not at all, the crane should be taken out of service. Any problem should be diagnosed and corrected before the crane is returned to regular service. Refer to Table 8.1 for some problem areas to consider and investigate. The first step to be taken before a troubleshooting procedure is started is to communicate with all personnel that the equipment is being removed from operation and to secure any/all lockout/tag out procedures. Failure to strictly follow this warning may lead to the injury or death of personnel.



Hazardous voltages are present in the motorized end truck, the control box, other electrical components and connections between these components.

Before performing any maintenance on the equipment, de-energize the electrical supply to the equipment, and lock and tag the supply device in the de-energized position. Refer to ANSI Z244.1.

Table 8.1
Troubleshooting Guide

Problem	Possible Cause	Corrective Action
Crane will not operate.	Power failure in power lines.	Check circuit breakers, switches and connections in power lines.
	Low voltage or frequency.	Check voltage and frequency or power supply. They must match with data on nameplate.
	Improper, loose or broken wire connection.	Check connections and lead wires. Check connections in control devices.
	Magnetic contactor not operating.	Check coil for open or short circuit. Check all connections in control circuit. Check for open contact. Replace as needed.
	Control transformer damaged.	Check transformer fuse. Check transformer coil. Check transformer for open winding.
	Motor burned out.	Replace motor.
Crane moves in wrong direction.	Reverse phasing.	Interchange any two power supply line leads.
	Improper electrical connections.	Check all connections with wiring diagram.
Crane travels in only one direction.	One circuit open.	Check circuit for loose connections.
	Broken conductor in pendant cable.	Check continuity of each conductor in the cable. If one is broken, replace cable.
	Magnetic contactor not operating.	Check coil for open or short circuit. Check all connections in motor circuit. Check for burned contacts. Replace as needed.

Table 8.1
Troubleshooting Guide (cont'd)

Problem	Possible Cause	Corrective Action
Crane does not move smoothly.	The end truck is not set at a right angle to the bridge beam or the left and right end trucks are not parallel to one another.	Set the end trucks at a right angle to the bridge beam and parallel to one another.
	Track wheels are unevenly worn.	Replace the wheels.
	A gap has formed between the guide rollers and the runway rail. May be due to wear in the guide roller.	Replace the guide rollers.
The motor fails to turn and makes a humming sound.	Electronic soft start's torque volume is adjusted too low.	Increase torque volume.
	The electronic soft start is damaged.	Repair or replace the soft start.
	The relay is damaged.	Verify that the motor is receiving all 3 phases.
Crane motor or motor brake overheating.	The motor is running in a single phase condition.	Repair wiring to restore 3 Phase operation
	Power supply voltage has dropped.	Ensure power supply is at proper voltage.
	Crane overloaded.	Reduce load to within rated capacity of crane.
	Excessive duty cycle.	Reduce frequency of operation.
	Crane drive gear box reducer is dragging.	Check for proper lubrication and or worn parts. Replace as necessary.
	Extreme external heating.	If ambient temperature exceeds 100°F, frequency of crane operation must be limited to avoid overheating. Special provisions may be required to ventilate the crane drive unit or shield it from the heat source.
	The rectifier is damaged.	Replace the rectifier.
Crane operates intermittently.	Poor collector contact.	Check for dirt or foreign matter on and wear of contact surfaces. Clean or replace as necessary.
	Broken wires.	Check wiring. Replace any broken wires.
	Worn contacts.	Locate and replace worn or burnt contacts.
Electrical shock.	The crane is not properly grounded.	Ground parts.
	The travel surface on the bridge beam or runway is coated with oil, grease, paint or corrosion.	Remove foreign material from travel surface or add ground conductor for hoist power.
	Water or foreign matter has penetrated the electric parts.	Dry parts and remove any foreign matter.
Oil leaks.	Worn or damaged gaskets and/or oil seals.	Replace worn or damaged parts.
	Joints not tight.	Tighten bolts to recommended torque.

Table 8.1
Troubleshooting Guide (cont'd)

Problem	Possible Cause	Corrective Action
The crane accelerates too slowly.	The electronic soft start's torque volume is adjusted too low.	Increase torque volume.
	The electronic soft start's timer is adjusted too low.	Increase the timer setting.
The crane accelerates too rapidly.	The electronic soft start's timer is adjusted too high.	Decrease the timer setting.
Stopping distance is too long.	Gear box parts are worn.	Replace.
Stopping distance is too short.	Gear box parts are broken or grinding.	Lubricate or replace as necessary.
Bumpers on the left and right end truck do not contact the end stops at the same time.	The crane is not square. May be due to the bolts coupling the end truck to the bridge beam are loose.	Adjust so that contact is made at the same time and tighten bolts.
	One motor is not driving.	Check motors.
	Crane drive gear box reducer is dragging.	Check for proper lubrication and or worn parts. Replace as necessary.
	End stops are set improperly.	Reset the end stops.

9.0 DIMENSIONS & SPECIFICATIONS

9.1 Under-Running Motorized End Truck Dimensions

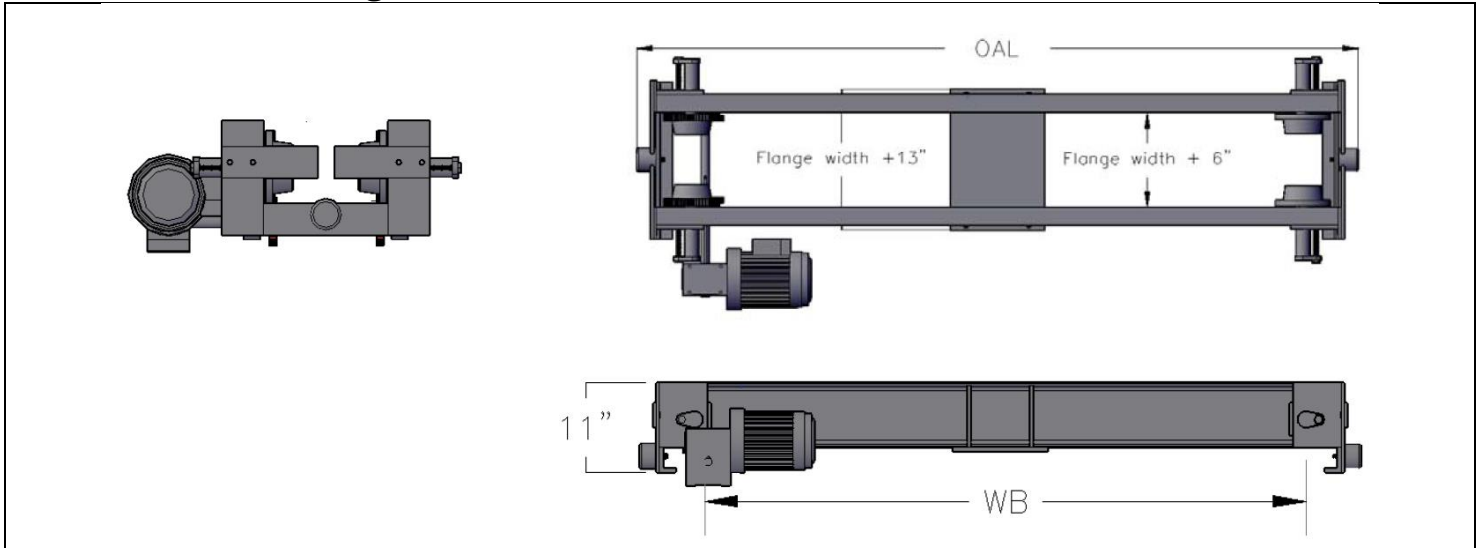

Model	Capacity	Wheel Ø	Max Span	Wheel Base (WB)	Overall Length (OAL)		
MEUS05036S13	3 Tons	5"	24'	36"	50"		
MEUS05036F13			28'	42"	56"		
MEUS05042S13			32'	48"	62"		
MEUS05042F13			40'	60"	74"		
MEUS05048S13			48'	72"	86"		
MEUS05048F13			60'	90"	104"		
MEUS05060S13			5 Tons	5"	24'	36"	50"
MEUS05060F13					28'	42"	56"
MEUS05072S13					32'	48"	62"
MEUS05072F13					40'	60"	74"
MEUS05090S13					48'	72"	86"
MEUS05090F13	60'	90"			104"		
MEUS06036S15	5 Tons	5"			24'	36"	50"
MEUS06036F15					28'	42"	56"
MEUS06042S15					32'	48"	62"
MEUS06042F15			40'	60"	74"		
MEUS06048S15			48'	72"	86"		
MEUS06048F15			60'	90"	104"		
MEUS06060S15			5 Tons	5"	24'	36"	50"
MEUS06060F15					28'	42"	56"
MEUS06072S15	5 Tons	5"	32'	48"	62"		
MEUS06072F15			40'	60"	74"		
MEUS06090S15	5 Tons	5"	48'	72"	86"		
MEUS06090F15			60'	90"	104"		

9.2 Under-Running Hand-Pushed End Truck Dimensions

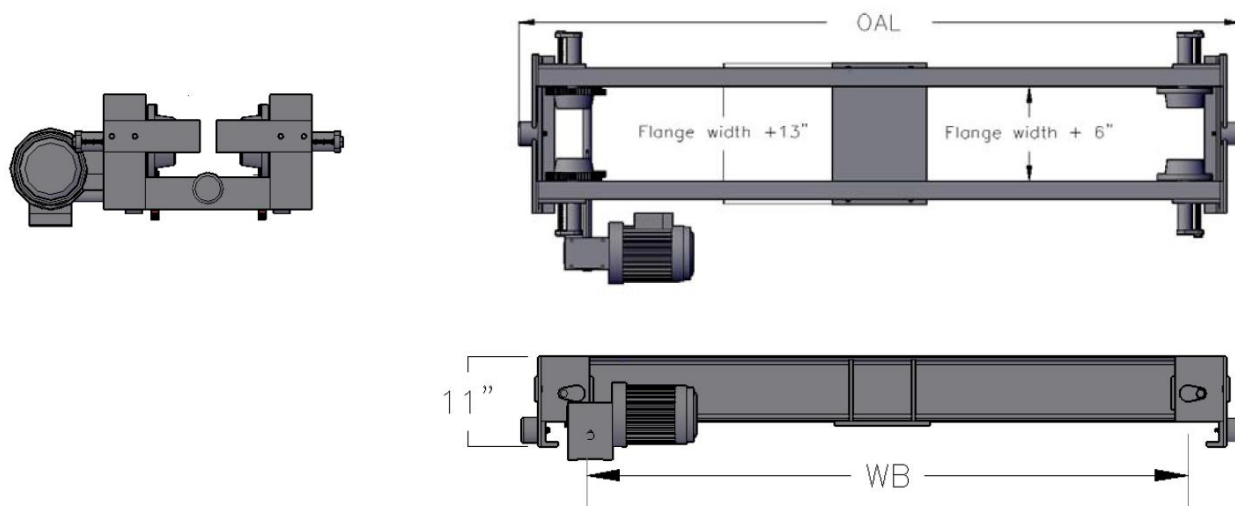

Model	Capacity	Wheel Ø	Max Span	Wheel Base (WB)	Overall Length (OAL)
MEUS05036P03	3 Tons	5"	24'	36"	50"
MEUS05042P03			28'	42"	56"
MEUS05048P03			32'	48"	62"
MEUS05060P03			40'	60"	74"
MEUS05072P03			48'	72"	86"
MEUS05090P03			60'	90"	104"
MEUS06036P05	5 Tons		24'	36"	50"
MEUS06042P05			28'	42"	56"
MEUS06048P05			32'	48"	62"
MEUS06060P05			40'	60"	74"
MEUS06072P05			48'	72"	86"
MEUS06090P05			60'	90"	104"

9.3 Under-Running Motorized End Truck Specifications

Model	Capacity	Wheel Ø	FPM	HP	240V Amps	460V Amps					
MEUS05036S13	3 Tons	5"	70	2 x 1.0	2 x 3.2	2 x 1.6					
MEUS05036F13			140								
MEUS05042S13			70								
MEUS05042F13			140								
MEUS05048S13			70								
MEUS05048F13			140								
MEUS05060S13			70								
MEUS05060F13			140								
MEUS05072S13			70								
MEUS05072F13			140								
MEUS05090S13			70								
MEUS05090F13			140								
MEUS06036S15			5 Tons				5"	70	2 x 1.0	2 x 3.2	2 x 1.6
MEUS06036F15								140			
MEUS06042S15	70										
MEUS06042F15	140										
MEUS06048S15	70										
MEUS06048F15	140										
MEUS06060S15	70										
MEUS06060F15	140										
MEUS06072S15	70										
MEUS06072F15	140										
MEUS06090S15	70										
MEUS06090F15	140										

9.4 Under-Running Hand-Pushed End Truck Specifications

Model	Capacity	Wheel Ø	Wheel Base	Span	Weight
MEUS05036P03	3 Tons	5"	36	24	208
MEUS05042P03			42	28	217
MEUS05048P03			48	32	227
MEUS05060P03			60	40	262
MEUS05072P03			72	48	282
MEUS05090P03			90	60	311
MEUS06036P05	5 Tons	6"	48	32	291
MEUS06042P05			60	40	332
MEUS06048P05			72	48	355
MEUS06060P05			90	60	390
MEUS06072P05	7.5 Tons	8"	48	32	571
MEUS06090P05			60	40	611
MEUS05036P03			72	48	638
MEUS05042P03			90	60	680

10.0 EXPLODED VIEW & PARTS LIST

Exploded View: Under-Running End Truck Assembly

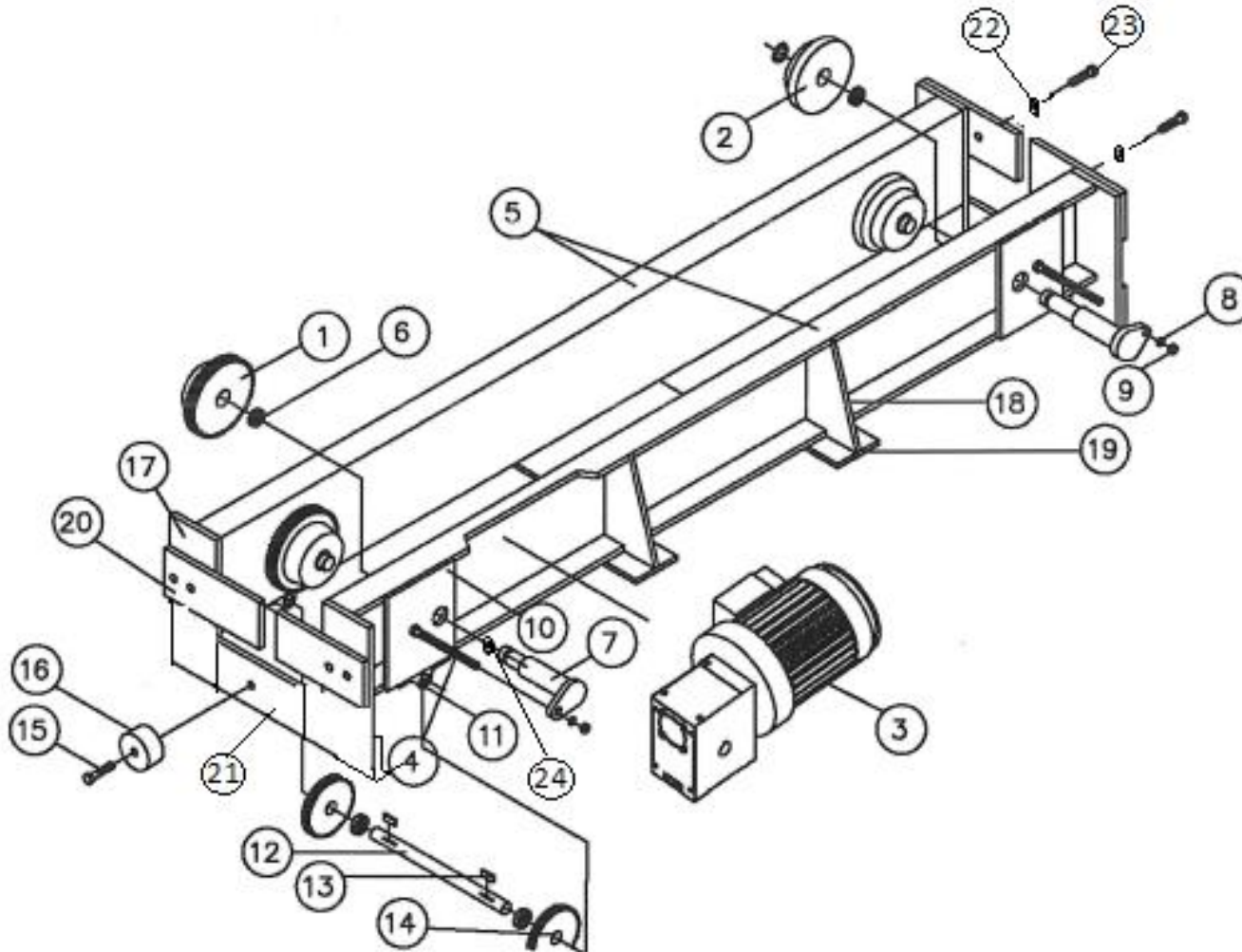

UNDER-RUNNING END TRUCKS

Models MEUS, MEUD

MEUS-0815

2721 NE 4th Ave Pompano FL, 33064 | (954) 367-6116

Parts List - Under-Running End Truck Assembly

Under-Running End Truck Assembly		Part Number
#	Part Name/Description	
1	Gear Wheel	ETWHG05
2	Plain Wheel	ETWHP05
3	Gear Motor	NEOM-60
4	Hex Screw	ETHS081218
5	Side Channel	AEC08110**N01
6	Bearing	ETBE05
7	Shaft	ETSH05
8	Flat Washer	ETFW08
9	Nut	ETNU071211
10	Shaft Plate	ABP080806
11	Axle Plate	ETAXP05
12	Axle	ETAX05
13	Axle Key	ETAXK05
14	Gear	ETGE05
15	Hex Screw	ETHS081218
16	Bumper	ETBU03
17	End Plate - 2	ABP060412
18	Gusset	ABP060804
19	Bottom Plate	ABP080618
20	End Plate - 1	ABP060309
21	End Angle	ABL08040220
22	Nut	ETNU081308
23	Hex Screw	ETSH081324
24	Snap Ring	ETSR05

** Wheel Base in Inches.