

MECHANICS HOIST MODEL MH

SINGLE PHASE ELECTRIC CHAIN HOIST

OPERATING, MAINTENANCE & PARTS MANUAL



ACI Hoist & Crane
689 S.W. 7th Terrace
Dania, FL 33004
Phone: 954 -367-7116
Fax: 954-272-0334
www.ACIHoist.com

Table of Contents

<u>SECTION</u>	<u>PAGE</u>
1. Dimensions and Specifications	1
2. Safety Precautions	1
3. Terms and Summary	2
4. Product Warnings & Cautions	3-4
5. Installation	4-8
5. 1. Unpacking	4
5. 2. Pre-Installation Checks	5
5. 3. Power Supply System	5
5. 3. 1. Connection to the Electrical Supply	6
5. 4. Mounting the Hoist	6
5. 5. Hook and Eye Suspension Hoists.....	6
5. 6. Load Chain	6
5. 6. 1. Load Chain Lubrication	6
5. 7. Chain Container	7
5. 7. 1. Installation of Standard Chain Container	7
5. 8. Test and Operational Checks	7-8
6. Operation Personnel	8
7. Inspection	8-14
7. 1. General	8
7. 2. Inspection Classification	9
7. 3. Frequent Inspection	9
7. 4. Periodic Inspection	10
7. 5. Occasionally Used Hoist	10
7. 6. Inspection Reports	10
7. 7. Inspection Methods and Criteria	11-14
8. Troubleshooting	15
9. Maintenance	16-18
9. 1. Chain Inspection	16
9. 2. Cutting the Chain	17
9. 3. Lubrication	17
9. 4. Testing.....	18
10. Repair Parts Ordering Instructions	19
11. Spare Parts & Parts List	20-24
12. Pendant Spare Parts & List	25
13. Wiring Diagram	26
ACI Hoist Warranty	27

1. DIMENSIONS AND SPECIFICATIONS:

Model	MH-005	MH-010	MH-020
Capacity (Ton)	1/4	1/2	1
Standard Lift (Ft)	10	10	10
Control Cable (Ft)	10	10	10
Operation Voltage (Single)	115V	115V	115V
Cycle (HZ)	60	60	60
Motor Power (HP) / Motor Amperage Full Load	1.8/16.5	1.8/16.5	1.8/16.9
Lifting Speed (FPM)	16	16	8
Chain Dia. (In)	0.25	0.25	0.25
Duty-Rate (ED %)	30%	30%	30%
NO. of Starts Per Hour	300	300	300
International Protection (IP) /(NEMA) *	IP 54 / NEMA 4	IP 54 / NEMA 4	IP 54 / NEMA 4
Insulation Class	F	F	F
Gross Weight (Lb)	53	53	62

* There is no direct conversion between NEMA types and IP codes.

2. SAFETY PRECAUTIONS:

Throughout the manual are safety precautions and instructions for awareness, along with information on potential hazards. Due to the complexities of this hoist and the environment in which it operates, situations may arise which are not directly discussed in detail in this manual. When a situation arises an ACI representative is available to answer your questions and assist you upon request.

This manual is provided as a guide to personnel involved with the operation and maintenance of the hoist equipment. Only trained and qualified personnel can operate and maintain this equipment. We recommend that all personnel who operate and maintain the hoist review and become familiar with this manual. In addition, we recommend that this manual be kept readily available for reference before beginning operation, maintenance and testing of this equipment.

Each Mechanics Hoist MH is built in accordance with the specifications contained herein and with our interpretation of applicable sections of the *American Society of Mechanical Engineers Code B30.16 'Overhead Hoist', and OSHA – Occupational Safety and Health Act. OSHA states that the National Electric Code applies to all electric hoist, the personnel installing the equipment is required to provide current overload protection and grounding.

Most accidents involving hoist are the result of violating safety rules during operation and/or lack of inspection and maintenance procedures.

3. TERMS AND SUMMARY

Notice, Caution, Warning and Danger

This manual contains important information to help you properly install, operate and maintain the ACI HOIST for maximum performance and safety purpose. Although you may be familiar with this equipment or similar equipment, it is very strongly recommended that you read this manual before attempting to operate, install or maintain the product. Please study the contents thoroughly before putting the HOIST in operation. The following signal words are used to identify the degree or level of hazard seriousness. Follow all instructions and warnings, failure to operate equipment as directed in manual may cause injury or property damage.



Notice is used to notify people of installation, operation or maintenance information which is important but not directly hazard related.



Caution indicates a potentially hazardous situation which, if not avoided, **may** result in **minor or moderate** injury or property damage.



Warning indicates an imminently hazardous situation which, if not avoided, **could** result in **death or serious** injury and property damage.



Danger indicates an imminently hazardous situation which, if not avoided, **will** result in **death or serious** injury and property damage.

4. PRODUCT WARNINGS:



DO NOT...

- A. **DO NOT** operate the hoist until you have read the Operating, Maintenance and parts manual.
- B. **DO NOT** operate a damaged or malfunctioning hoist.
- C. **DO NOT** use the hoist to lift, support or transport people.
- D. **DO NOT** operate the hoist until all personnel are clear of the supported load.
- E. **DO NOT** lift loads over personnel.
- F. **DO NOT** remove or obscure the warning labels on the hoist.
- G. **DO NOT** operate a hoist on which the safety place cards or decals are missing or illegible.
- H. **DO NOT** operate a hoist which has been modified without the manufacturer's approval or without certification that it is in conformity with ANSI/ASME B30 volumes.
- I. **DO NOT** use hoist with twisted, kinked, damaged or worn load chain.
- J. **DO NOT** use load chain as a sling or wrap the chain around the load.
- K. **DO NOT** operate a hoist unless the load slings or other approved single attachments are properly sized and seated in the hook saddle.
- L. **DO NOT** lift more than the rated load for the hoist.
- M. **DO NOT** operate unless load is centered under the hoist properly.
- N. **DO NOT** apply the load unless load chain is properly seated in the chain sprocket(s).
- O. **DO NOT** apply load if bearing prevents equal loading on all load supporting chains.
- P. **DO NOT** operate hoist when it is restricted from forming a straight line from hook to hook in the direction of loading.
- Q. **DO NOT** attempt to lengthen the load chain or repair the damaged load chain.
- R. **DO NOT** apply the load to the tip of the hook or to the hook latch.
- S. **DO NOT** operate beyond the limits of the load chain travel.
- T. **DO NOT** leave the load (supported by the hoist) unattended unless specific precautions have been taken.
- U. **DO NOT** operate a hoist until it has been securely attached to a suitable support.
- V. **DO NOT** allow the load chain or hook to be used as an electrical or welding ground.
- W. **DO NOT** allow the load chain or hook to be touched by a live welding electrode.

DO...

- A. **DO** shut down a hoist that malfunctions or performs unusually and report such malfunction.
- B. **DO** make sure that the hoists limit switches function properly.
- C. **DO** warn personnel of an approaching load.
- D. **DO** take up slack carefully – make sure the load is balanced and the load holding action is secure before continuing.
- E. **DO** protect the hoist's load chain from weld splatter or other damaging contaminants.

PRODUCT CAUTIONS:

 CAUTION 
Caution indicates a potentially hazardous situation which, if not avoided, may result in minor or moderate injury , or property damage.

DO NOT:

- A. **DO NOT** allow your attention to be diverted from operating the hoist.
- B. **DO NOT** allow the hoist to be subjected to sharp contact with other hoist, structures or objects through misuse.
- C. **DO NOT** adjust or repair the hoist unless qualified to perform such adjustments or repairs.
- D. **DO NOT** use the hoist overload limiting clutch to measure the load.

DO:

- A. **DO** inspect the hoist regularly, replace damaged or worn parts and keep appropriate records of maintenance.
- B. **DO** maintain firm footing or be otherwise secured when operating the hoist.
- C. **DO** check brake function by tensioning the hoist prior to each lift operation.
- D. **DO** lubricate load chain per hoist manufacturer's recommendations.
- E. **DO** use Mechanics Hoist MH recommended parts when repairing the hoist unit.
- F. **DO** use the hook latches. Latches are to retain slings, chains, etc. under slack conditions only.
- G. **DO** make sure the hook latches are closed and not supporting any parts of the load.
- H. **DO** make sure the load is free to move and will clear all obstructions.
- I. **DO** avoid swinging the load or hook.
- J. **DO** make sure the hook travel is in the same direction as shown on the controls.

5. INSTALLATION:

5. 1. UNPACKING:

Once package has been opened, carefully inspect the hoist frame, hooks, chain and control station for damage that may have occurred during shipment. If damage is found please contact your ACI representatives immediately at, toll free 1-866-424-6478.

 WARNING 
Operating a unit with obvious external damage may cause load to drop and could result in personal injury and/or property damage.
To avoid injury Carefully check unit for external damage prior to installation.

Make sure to check that the power supply to which the hoist is to be connected matches the information shown on the identification plate located on the bottom of the hoist.

Before using the hoist, fill in the information below:

Model No. _____

Serial No. _____

Purchase Date _____

5. 2. PRE--INSTALLATION CHECKS:



- a. Check for transit damage.
- b. Check that all fasteners and joints are tight and secure.
- c. Check the capacity of the lifting unit and bottom block.
- d. Check that all external wiring is in good order.
- e. Check that the load chain is in good order.

5. 3. POWER SUPPLY SYSTEM:

To insure proper operation, to avoid damage to the hoist and electrical system, and to reduce the risk of electrical shock or fire, the branch circuit supplying power to the hoist must:

- a. Be in accordance with the National Electrical Code (ANSI/NFPA-70) and applicable National, State and Local codes.
- b. Effectively ground the hoist in accordance with the National Electrical Code and other applicable codes. Proper grounding provides a path with the least resistance for the electrical current to travel reducing the risk of electrical shock. The standard power cord is equipped with a three prong plug, used with our 115V-1PH-60HZ unit. Make sure that the receptacle opening that receives the longest prong is properly grounded.
- c. Have ample capacity to prevent excessive voltage drop during starting and operation. When determining the size of branch circuit components and conductors, special consideration should be given to the starting current amps (approximately three times that shown on the hoist identification plate) and the length of the conductors. As a minimum, the system should be rated for 20 amps and the system should have #14 AWG or larger, wiring.
- d. Include slow blow type fuses or inverse trip time circuit breakers to permit the hoist to start and accelerate the load.
- e. Include a disconnecting means capable of being locked in the 'open' position.

 WARNING 
Failure to properly ground the hoist presents the danger of electric shock.
To avoid injury
Permanently ground the hoist as instructed in this manual.



 WARNING 
Failure to provide a proper power supply system for the hoist may cause hoist damage and offers the potential for a fire.
To avoid injury
Provide the hoist with a 20 amp, minimum, over current protected power supply per the National Electrical Code (ANSI/NFPA 70) and applicable local codes as instructed in this manual.

5. 3. 1. CONNECTION TO THE ELECTRICAL SUPPLY:

An adequate supply system is required along the total length of travel (where appropriate). The supply voltage and frequency, at which the hoist operates, is marked on the motor rating plate. It is imperative to check before connecting the unit that these figures correspond with those of the supply voltage.

5. 4. MOUNTING THE HOIST:

Hang the hoist from its intended support. The structure used to support the hoist must have sufficient strength to withstand several times the load amount. If you are not sure of the weight the structure can hold, consult a registered engineer and the local building codes.

 WARNING 
Suspending the hoist from an inadequate support could allow the hoist and load to fall and cause personal injury and/or property damage.
To avoid injury Make sure that the structure has sufficient strength to withstand several times the hoist and its rated load amount. Using the upper hook, hang the hoist from the support. Make sure the hoist is solidly held in the uppermost part of the hook arc and the latch is tightly against the hook tip.

5. 5. HOOK AND EYE SUSPENSION HOISTS:



The suspension point should be of a correct size to admit the top hook or eye of the hoist and allow it to rest properly on the saddle. It must be adequate to support the hoist while it is being operated at its maximum capacity (safe working load).

5. 6. LOAD CHAIN:

The chain should feed smoothly into and away from the hoist and hook block (¼ ton and 1 ton). If the chain binds, jumps or is noisy, First clean and lubricate the chain, if trouble persists inspect chain and mating parts for wear, distortion and other damages.

5. 6. 1. LOAD CHAIN LUBRICATION:

Always lubricate load chain weekly or more frequently depending on severity of service. Lubricate load chain with a light coat of Lubriplate Bar and Chain Oil 10-R (Fiske Bros. Refining Co.) or equal lubricant. Be sure the lubricant reaches the bearing surfaces between the links. Remove the excess oil from the chain.

 WARNING 
Used motor oils contain unknown carcinogenic materials.
TO AVOID HEALTH PROBLEMS: Never use used motor oils as a chain lubricant. Only use Lubriplate Bar and Chain Oil 10-R as a lubricant for the load chain.

5. 7. CHAIN CONTAINER:

For installations where the slack chain hanging from the hoist may be objectionable or hazardous, the use of a chain container is recommended.



5. 7. 1. INSTALLATION OF STANDARD CHAIN CONTAINER:



1. Remove both bolts from the chain container mounting bracket.
2. Attach the chain container to the bracket.
3. Reinsert the bolts.

5. 8. TEST AND OPERATIONAL CHECKS:

On completion of installation, but before the hoist is put into regular service, the following procedure should be carried out:

- a. Record the hoist's Code, Lot and Serial Number from the name plate on the hoist.
- b. Check that the hoist is properly installed to either a fixed point or trolley, whichever applies.
- c. If hoist is installed on a trolley, ensure that:
 - The trolley is properly installed on the beam.
 - The stops for the trolley are correctly positioned and securely installed on the beam.
- d. Isolate the power supply.
- e. Check that all mechanical and electrical joints and connections are tight and secure.
- f. Check that all nuts, bolts and split pins (cotter pins) are securely fastened.
- g. Confirm proper operation:
 - Before operating read and become familiar with this manual.
 - Before operating check to ensure that the hoist (and trolley) meet the Inspection, Testing and Maintenance requirements of ANSI/ASME B30.16.
 - Before operating check that nothing will interfere with the full range of the hoist's (and trolley's) operation.
- h. Switch on the power supply.
- i. Run lightly with no load, throughout the full extent of the hoist and check that the operation is smooth at all times.
- j. Check the operation of the hoist brake, run under light load and full load conditions.

 **CAUTION** 

Check supply voltage before everyday use. If the voltage varies more than 10% of the rated value, electrical devices may not function normally.

 **WARNING** 

Confirm the adequacy of the rated capacity for all slings, chains, wire ropes and all other lifting attachments before use. Inspect all load suspension members for damage prior to use and replace or repair all damaged parts.

 **WARNING** 

Verify and correct all chain irregularities prior to operating the hoist.

6. OPERATION PERSONNEL:

For independent operation or maintenance of chain hoist, the owner may only employ persons as following:

- a. Must be at least 18 years of age.
- b. Must be mentally and physically suitable.
- c. Those who have been instructed in the operation and/or maintenance of the chain hoist and have proven their qualification to the owner in this respect. In addition to theoretical training, instruction also includes sufficient practical operating experience as well as acquiring the ability to identify defects which are a hazard to safe operations.

7. INSPECTION:

7. 1. GENERAL:

The inspection procedure is based on ANSI/ASME B30.16. The following definitions are from ANSI/ASME B30.16 and pertain to the inspection procedure below.

- a. Designated Person: A person assigned or selected as being competent to perform the specific duties to which he/she is assigned.
- b. Qualified Person: A person who, by possession of a recognized degree or certificate of professional standing, or who, by extensive knowledge, training and experience has successfully demonstrated the ability to solve or resolve problems relating to the subject matter at work.
- c. Normal Service: A distributed service which involves operation with randomly distributed loads within the rated load limit or uniform loads less than 65% of rated load for not more than 25% of the time.
- d. Heavy Service: A service which involves operation within the rated load limit which exceeds normal service.
- e. Severe Service: A service which involves normal or heavy service with abnormal operating conditions.

7. 2. INSPECTION CLASSIFICATION:

The inspection procedure for hoist in regular service is divided into two general classifications based upon the intervals at which inspection should be performed. The intervals in turn are dependant upon the nature of the critical components of the hoist and the degree of their exposure to wear, deterioration or malfunction. The two general classifications are designated as Frequent and Periodic, with respective intervals between inspections as defined below.

 CAUTION 
Initial Inspection: Prior to initial use, all new, altered or modified hoist shall be inspected by a designated person to ensure compliance with the applicable provisions of this manual.

FREQUENT INSPECTIONS - Frequent inspections are visual examinations by the operator or other designated personnel with interval per the following criteria.

- a. Normal Service – Monthly
- b. Heavy Service – Weekly to Monthly
- c. Severe Service – Daily to Weekly
- d. Special or Infrequent Service – As recommended by a qualified person before and after each occurrence.

PERIODIC INSPECTIONS - Periodic inspections are visual inspections by a designated person with interval per the following criteria.

- a. Normal Service – Yearly
- b. Heavy Service – Semi-Annually
- c. Severe Service – Quarterly
- d. Special or Infrequent Service – As recommended by a qualified person before the first occurrence.

7. 3. FREQUENT INSPECTION:

Inspections should be made on a Frequent basis in accordance with Table 7-1, “Frequent Inspection.” Included in these Frequent Inspections are observations made during operation for any defects or damage that might appear between Periodic Inspections. Frequent Inspections shall be made by a designated person to ensure that the hoist is maintained in safe working condition.

TABLE 7-1 FREQUENT INSPECTION
1. Check all functional operating mechanisms for maladjustment and unusual sounds.
2. Check the operation of the limit switch and associated components.
3. Check the hoist braking system for proper operation.
4. Check the hooks in accordance with ANSI/ASME B30.10.
5. Check the hook latch operation.
6. Check the Load Chain in accordance with Section 7. 7.
7. Check the Load Chain reeving.

7.4. PERIODIC INSPECTION:

Inspections should be made on a Periodic basis in accordance with Table 7-2, "Periodic Inspection." Evaluation and resolution of the results of Periodic Inspections shall be made by a designated person to ensure that the hoist is maintained in safe working condition.



 WARNING 
Periodic Inspection: For inspections where load suspension parts of the hoist are disassembled, a load test per ANSI/ASME B30.16 must be performed on the hoist after it is re-assembled and prior to its return to service.

TABLE 7-2 PERIODIC INSPECTION
1. Complete the requirements of Frequent Inspection.
2. Check to ensure there is no evidence of loose bolts, nuts or rivets.
3. Check to ensure there is no evidence of damage or excessive wear of load and idler sheaves.
4. Check to ensure there is no evidence of damage to hook retaining nuts or collars and pins, and welds or rivets used to secure the retaining members.
5. Check to ensure the warning label is properly attached to the hoist and legible.
6. Check to ensure the function labels on the pendant control stations are legible.
7. Check to ensure there is no evidence of worn, corroded, cracked or distorted parts such as load blocks, suspension housing, chain attachments, clevises, yokes, suspension bolts, shafts, gears, bearings, pins and rollers.
8. Check to ensure there is no evidence of damage to the supporting structure or trolley, if used.
9. Check to ensure there is no evidence of damage to the end connections of the load chain.
10. Check to ensure there is no evidence of excessive wear on motor or load brake.
11. Check to ensure there is no electrical apparatus for signs of pitting or any deterioration of visible controller contacts.

7.5. OCCASIONALLY USED HOIST:

Hoists that are infrequently used shall be inspected as follows before placing the hoist in service:

- a. Hoist idle more than one year: Inspect per Periodic Inspection.
- b. Hoist idle more than one month, less than one year: Inspect per Frequent Inspection.

7.6. INSPECTION REPORTS:

- a. Dated inspection reports and records should be maintained for the hoist Periodic Inspection intervals. These records should be stored where they are available to personnel involved with the inspection, maintenance or operation of the hoist.
- b. A long range chain inspection program should be established and should include records of an examination of the chains that are removed from service. To create a relationship between visual observation and actual condition of the chain.

7. 7. INSPECTION METHODS AND CRITERIA

This section covers the inspection of specific items. The list of items in this section is based on those listed in ANSI/ASME B30.16 for the Frequent and Periodic Inspection. In accordance with ANSI/ASME B30 volumes listed under the General heading on the previous pages, these inspections are not intended to involve disassembly of the hoist. Rather, disassembly for further inspection would be required if frequent or periodic inspection results so indicate. Such disassembly and further inspection should only be performed by a certified or qualified person trained in the disassembly and re-assembly of the hoist.

Item	Method	Criteria	Action
Functional operating mechanisms	Visual, Auditory	Mechanisms should be properly adjusted and should not produce unusual sounds when operated.	Repair or replace as required
Braking System Operation	Function	Braking distance with rated capacity should not exceed approximately five chain links. Refer to table 7.7	Repair or replace as required
Hooks (surface condition)	Visual	Should be free of significant rust, weld splatter, deep nicks or gouges.	Replace
Hooks (fretting wear)	Measure	The "F" and "T" dimensions should not be less than discard value listed in Table 7-5.	Replace
Hooks (stretch)	Measure	The "D" dimension should not exceed the measured value for discard from Table 7-5.	Replace
Hooks (bent shank or neck)	Visual	Shank and neck portions of hook should be free of deformations.	Replace
Hooks (yoke assembly)	Visual	Should be free of significant rust, weld splatter, nicks or gouges. Holes should not be elongated, fasteners should not be loose and there should be no gap between mating parts.	Tighten or replace as required
Hooks (swivel bearing)	Visual, Function	Bearing parts and surfaces should not show significant wear. They should be free of dirt, grime and deformations. Hook should rotate freely with no roughness.	Clean/Lubricate, or replace as required
Hooks (hook latches)	Visual, Function	Latch should not be deformed. Attachment of latch to hook should not be loose. Latch spring should not be missing and should not be weak. Latch movement should not be stiff – when depressed and released latch should snap smartly to its closed position.	Replace
Load Chain (surface condition)	Visual	Should be free of rust, nicks, gouges, dents and weld spatter. Links should not be deformed or show signs of abrasion. Surfaces where links bear on one another should be free of significant wear.	Replace
Load Chain (pitch and wire diameter)	Measure	The "G" dimension should not be greater than maximum value listed in Table 7-6. The "E" dimension should not be less than minimum value listed in Table 7-6.	Replace. Inspect Load Sheave by qualified personnel
Load Chain (lubrication)	Visual, Auditory	Entire surface of each link should be coated with lubricant and free of dirt/grime. Chain should not emit cracking noise when hoisting a load.	Clean/Lubricate
Load Chain (reeving)	Visual	Chain should be reeved properly through load sheave. Chain, cushion rubbers, washers and stoppers should be installed properly.	Reeve/ Install chain properly
Chain Container	Visual	Container should not be damaged. Brackets should not be deformed or missing.	Replace
Housing and Mechanical Components	Visual, Auditory, Vibration, Function	Hoist components including load blocks, suspension housing, chain attachments, clevises, yokes, suspension bolts, shafts, gears, bearings, pins and rollers should be free of cracks, distortion, significant wear and corrosion. Evidence of same can be detected visually or via detection of unusual sounds or vibration during operation.	Replace
Bolts, Nuts and Rivets	Visual, Check with proper tool	Bolts, nuts and rivets should not be loose.	Tighten or replace as required
Motor Brushes	Measure, Visual	The "B" dimension should not be less than minimum value listed in Table 7-4.	Replace

Table 7-3 Hoist Inspection Methods and Criteria			
Item	Method	Criteria	Action
Gear Box oil	Visual ,Function	Oil for the gear box is pres-supplied with a new hoist. Refer to table 7.7	Replace
Contactors Contacts	Visual	Contacts should be free of significant pitting or deterioration.	Replace
Cushion Rubber	Visual	Should be free of significant deformation.	Replace
Pendant (switches)	Function	Depressing and releasing push buttons should make and break contacts in switch contact block and result in corresponding electrical continuity or open circuit. Push buttons should be interlocked either mechanically or electrically to prevent simultaneous energization of circuits for opposing motions. Example: Up and Down	Repair or replace as necessary
Pendant (housing)	Visual	Pendant housing should be free of cracks and mating surfaces of parts should seal without gaps.	Replace
Pendant (wiring)	Visual	Wire connections to switches in pendant should not be loose or damaged.	Tighten or repair
Pendant (cord)	Visual, Electrical Continuity	Surface of cord should be free from nicks, gouges and abrasions. Each conductor in cord should have 100% electrical continuity even when cord is flexed back and forth. Pendant cord strain relief cable should absorb the entire load associated with forces applied to the pendant.	Replace
Pendant (labels)	Visual	Labels denoting functions should be legible.	Replace
Warning Labels	Visual	Warning labels should be affixed to the hoist and they should be legible.	Replace
Hoist Capacity Label	Visual	The label that indicates the capacity of the hoist should be legible and securely attached to the hoist.	Replace

Table 7-4 Motor Brush Dimensions	
	
Capacity (Ton)	"B" Dimension (inch)
	Discard
¼ to 1	0.24

Table 7-5 Top Hook & Bottom Hook Dimensions							
							
Capacity (Ton)	Hook	Nominal "D" Dimension (inch) *		"F" Dimension (inch)		"C" Dimension (inch)	
		Standard	Discard	Standard	Discard	Standard	Discard
¼ to 1	Bottom	1.54	1.70	0.94	0.85	0.75	0.68
	Top	1.54	1.70	0.94	0.85	0.75	0.68

* These values are nominal since the dimension is not controlled to a tolerance. The "D" dimension should be measured when the hook is new, this becomes a reference measurement. Subsequent measurements are compared to this reference to make determinations about hook deformation/stretch.

Table 7-6 Chain Wear Dimensions

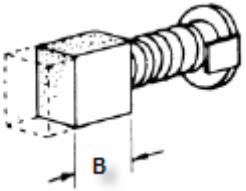
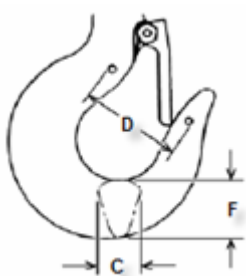
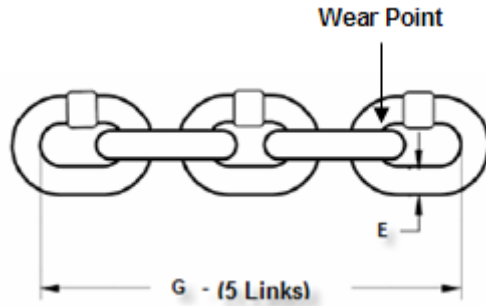

Capacity (Ton)	"G" Dimension (inch)		"E" Dimension Wear Limit (inch)	
	Standard	Discard	Standard	Discard
¼ to 1	3.78	3.96	0.25	0.22

* Chain wear will occur in section of chain that passes thru the sheave.

Table 7-7: Gear Brakes



Instructions

Our gear brakes are made of durable copper material but if a brake needs repair, the brake assembly must be replaced in its entirety. Read the instructions below when replacing the gear brakes:

1. Place an empty container under the gear box cap to catch the oil.
2. Open the gear box cap.
3. Empty the oil into the container.

The brake assembly is now visible for replacing. Once the brake assembly is replaced, and the unit is sealed, use the five chain links criteria to assure that the brake is working properly. To replace the oil follow the instruction below:

1. Follow steps 1-3 above.
2. Pour CPC E.P. Lubricant MD 180 and Grease NLGI according to the following chart.

Oil-Grease Chart

Model	Grease NLGI (qt)	Oil HD680 (qt)	Total (qt)
MH-010 & MH-020	1/16 qt	1/16 qt	1/8 qt

Reference:
1 Cup = ¼ Quart

8. TROUBLESHOOTING:

Table 7-8 Troubleshooting Guide		
Symptom	Cause	Remedy
Hoist will not operate	Loss of power	Check circuit breakers, switches, fuses and connections on power lines/cable.
	Wrong voltage or frequency	Check voltage and frequency of power supply against the rating on the nameplate of the motor.
	Hoist overload	Reduce load to within rated capacity of hoist.
	Improper, loose or broken wire in the hoist electrical system	Shut off power supply, check wiring connections on hoist control panel and inside push button pendant.
	Brush wear	Inspect both motor brushes per Table 7-4 and replace if necessary.
	Fuses burned out	Replace fuses.
	Motor burned out	Replace motor frame/stator, shaft/rotor and any other damaged parts.
Hoist lifts but will not lower	Faulty switch in pendant	Check electrical continuity. Check electrical connections. Replace or repair as needed.
	Broken conductor in pendant cord	Check the continuity for each conductor in the cable. If one is broken, replace the entire cable.
Hoist lowers but will not lift	Hoist overload	Reduce load to within rated capacity of hoist.
	Worn friction clutch	Repair by a qualified person trained in the repair of hoists and proper friction clutch adjustment procedures. Replace as needed.
	Broken conductor in pendant cord	Check the continuity for each conductor in the cable. If one is broken, replace the entire cable.
	Faulty switch in pendant	Check electrical continuity. Check electrical connections. Replace or repair as needed.
	Low voltage in hoist's power supply	Determine cause of low voltage and bring to within plus or minus 5% of the voltage specified on the motor nameplate. The voltage should be measured at the hoist contactor.
Hoist will not lift rated load or does not have the proper lifting speed	Hoist overload	Reduce load to within rated capacity.
	Low voltage in hoist's power supply	Determine cause of low voltage and bring to within plus or minus 5% of the voltage specified on the motor nameplate. The voltage should be measured at the hoist contactor.
	Faulty friction clutch	If abnormal operation or slippage occurs do NOT attempt to disassemble or adjust the Mechanical Load Brake with Friction Clutch. Replace the worn or malfunctioning Mechanical Load Brake with Friction Clutch as an assembly with a new, factory adjusted part.
Load drifts excessively when hoist is stopped	Motor demagnetized	Motor demagnetizing is generally caused from using the hoist beyond its duty rating. Replace stator assembly and reduce usage to comply with the duty rating stated.
	Improper gear oil	Replace oil with the correct gear oil.
Hoist operates intermittently	Loose connection in circuit	Check all wires and terminals for bad connections. Replace as needed.
	Collectors making poor contact	Check movement of spring loaded arm, weak spring, connections and shoe. Replace as needed.
	Broken conductor in pendant cord	Check for intermittent continuity in each conductor in the pendant cord. Replace the entire pendant cord if continuity is not constant.



9. MAINTENANCE:

9. 1. CHAIN INSPECTION:

- a. First clean chain with a non-caustic/non-acid type solvent and make a link by link inspection for nicks, gouges, twisted links, weld splatter, corrosion pits, striations (minute parallel lines), cracks in weld areas, wear and stretching. A chain with any of these defects **must** be replaced before use.
- b. When checking the chain for wear, check the part of the chain that goes through the lift wheel of the hoist most often. Check the interlink area of the chain links for the point of maximum wear. Measure and record the stock diameter at this point of the link. Then measure stock diameter in the same area on a link that does not pass through the lift wheel. Compare these two measurements. If the stock diameter of the worn link is 0.010 inches or more, than the stock diameter of the unworn link, the chain must be replaced.
- c. Use only a 'Knife-edge' caliper to eliminate the possibility of false reading by not measuring full pitch length.
- d. Check the chain for stretch with a vernier caliper. Select an unused, unstretched section of chain then measure and record the length. Measure and record the same length on a worn section of chain. Obtain the amount of stretch and wear by subtracting the measurement of the unworn section from the worn section. If the result is greater than 0.145 inch, the chain **must** be replaced.
- e. These chains are specially heat treated and hardened, they should **never** be repaired.

Important – Do not use replaced chain for other purposes such as lifting or pulling. Load chain may break suddenly without visual deformation. For this reason, cut replaced chain into short lengths to prevent use after disposal.



NOTE: A worn chain can be an indication of worn hoist components. For this reason, the hoist's chain guide, hook block and lift wheel should be examined for wear and replaced as necessary when replacing worn chain.

 WARNING 
Use of commercial or other manufactures' chain and parts to repair MH Hoists may cause load loss.
To avoid injury Use only factory supplied replacement load chain and parts. Chain and parts may look alike, but factory original chain and parts are made of specific materials or processed to achieve specific properties.

9. 2. CUTTING THE CHAIN:

The load chain is hardened and is difficult to cut. The following methods are recommended when cutting a length of new chain from stock or cutting off worn chain. **Always wear eye protection when cutting the load chain.**

- a. Use a grinder and nick the link on both sides, then secure the link with a vise and break off the chain link with a hammer.
- b. Use a 7" minimum diameter by 1/8" thick abrasive wheel (or type recommended by your wheel supplier) that will clear the adjacent links.

 WARNING 
Cutting chain can produce flying particles.
To avoid health problems:
<ul style="list-style-type: none">• Wear eye protection.• Place shield over chain to prevent flying objects.

9. 3. LUBRICATION:

- a. **Load Chain:** The full length of the chain must be lubricated, including where the chain passes over the chain wheel(s). Ensure that the contact points between the links (I.E. the chain saddles) are adequately lubricated. A small amount of lubrication will greatly increase the life of the load chain. DO NOT allow the chain to run dry. Keep the chain clean and lubricate the chain at regular intervals with Lubriplate Bar and Chain Oil 10-R or equal lubricant. Normally, weekly lubrication and cleaning is satisfactory, but under hot and dirty conditions, it may be necessary to clean the chain at least once daily and lubricate the chain several times between cleanings. When lubricating the chain, apply sufficient lubricant to obtain natural run-off and full coverage, especially in the interlink area.

 WARNING 
Used motor oils contain known carcinogenic materials.
To avoid health problems
Never use used motor oils as a chain lubricant. Only use Lubriplate Bar and Chain Oil 10-R as a lubricant for the load chain.

- b. **Gearbox:** For ambient temperature of approx., 50°F to 122°F, a gear oil of Mm²/S at 104°F, with mild high-pressure additives should be used. Examples of the oil types that can be used are:
- c.
 - Din 51502 Clp 220
 - E.G. Bp Energol Gr-Xp 20
 - Esso Spartan Ep 220
 - Shell Omala Oil S2 G
 - Mobil gear 630
 - Aral Degol Bg 220

- c. **Important:** The bottom block must not touch the floor; if necessary adjust the position of the chain stop on the slack end of the chain.

 WARNING 
The lubricants used for the Mechanics Hoist MH may contain hazardous materials that mandate specific handling and disposal procedures.
To avoid contact and contamination
Handle and dispose of lubricants only as directed in applicable material safety data

sheets and in accordance with applicable local, state and federal regulations.

9. 4. TESTING:

Before using, all altered, repaired or used hoists that have not been operated for the previous 12 months must be tested by the user for proper operation.

- a. Test the unit without a load and then test the unit with a light load of 50 pounds (23 kg) times the number of load chain supporting parts to be sure that the hoist operates properly and that the brake holds the load when control is released.
- b. Next test with a load of 125% of the rated capacity. In addition, hoists in which load sustaining parts have been replaced, you should test the load with 125% of rated capacity by or under an appointed person and a written report prepared for record purposes.
- c. In accordance with the CMAA 78, it is required to have a 100% load test preformed every four years.

For assistance information on testing, please ACI toll free at 1-866-424-6478.

 Caution 
The hoist must only be inspected and maintained by qualified, competent and trained personnel.

or additional inspection and contact your representative

Table 9-1 Lubrication Chart		
PART	DESCRIPTION	FREQUENCY
Clutch	Check operation of the slipping clutch (if fitted)	Before each shift
Cables	Check control cables and strain relief elements	Before each shift
Pendant	Check control pendant housing for damage	Before each shift
Electrical	Check electrical switch gear and wiring	Before each shift, Monthly
Hook	Check suspension eye/suspension hook assembly	After 50-200 service hours
Bottom Block	Lubricate chain sprocket bearing and check for a tight fit of securing bolts.	After 50-200 service hours
Hook	Check tight fit of securing bolts on load hook assembly	Before each shift, After 50-200 service hours
Chain	Lubricate chain, under normal usage Lubricate chain, under heavy usage	After 50-200 service hours
Chain	Check ends of chain/chain bag to ensure they are secure	Before each shift
Brake	Check brake stroke, brake disc and adjust brake as required	After 50-200 service hours
Oil	Check oil level and change oil (if needed)	Before each shift
Hook	Check hooks for cracks, deformation, pitting and wear	After 50-200 service hours
Clips/Bolts/Nuts	Check securing elements for tight fit and corrosion	After 50-200 service hours
Brakes	Check operation of brakes	After 50-200 service hours

10. REPAIR PARTS ORDERING INSTRUCTIONS

This parts and instruction manual contains information required to install and maintain your hoist. To insure prompt service, each repair parts order should be placed with ACI, and must contain the following information:

- a. Serial number and Model number from the hoist name plate, located on the side of the hoist.
- b. Voltage, Amp and Horse Power from the hoist name plate, located on the side of the hoist.
- c. Hoist capacity from the hoist name plate, located on the side of the hoist.
- d. Hoist Speed from the hoist name plate, located on the side of the hoist.
- e. Item number of part from the part list.
- f. Part name from the part list.
- g. Part number from the part list.
- h. Quantity of parts requested.

Note: When ordering replacement parts, it is recommended that consideration be given to the need for also ordering such items as gaskets, fasteners, seals, etc. These items may be damaged or lost during disassembly or just unfit for future use because of deterioration from age or service.

 WARNING 
Use of commercial or other manufactures' chain and parts to repair MH Hoists may cause load loss.
To avoid injury
Use only factory supplied replacement load chain and parts. Chain and parts may look alike, but factory original chain and parts are made of specific materials or processed to achieve specific properties.

11. SPARE PARTS AND PARTS LIST
Model # MH-005 & MH-010

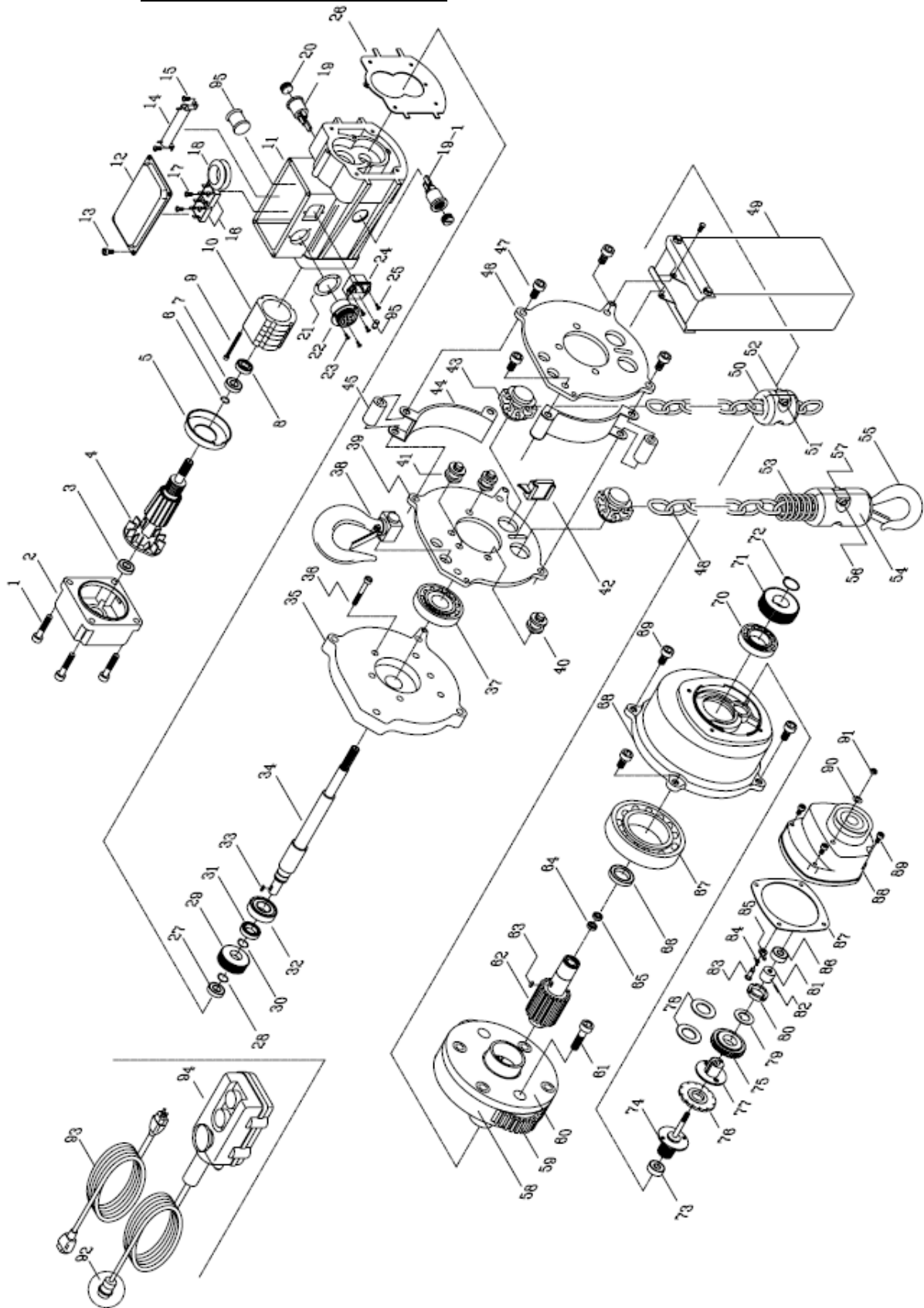

Model # MH-020

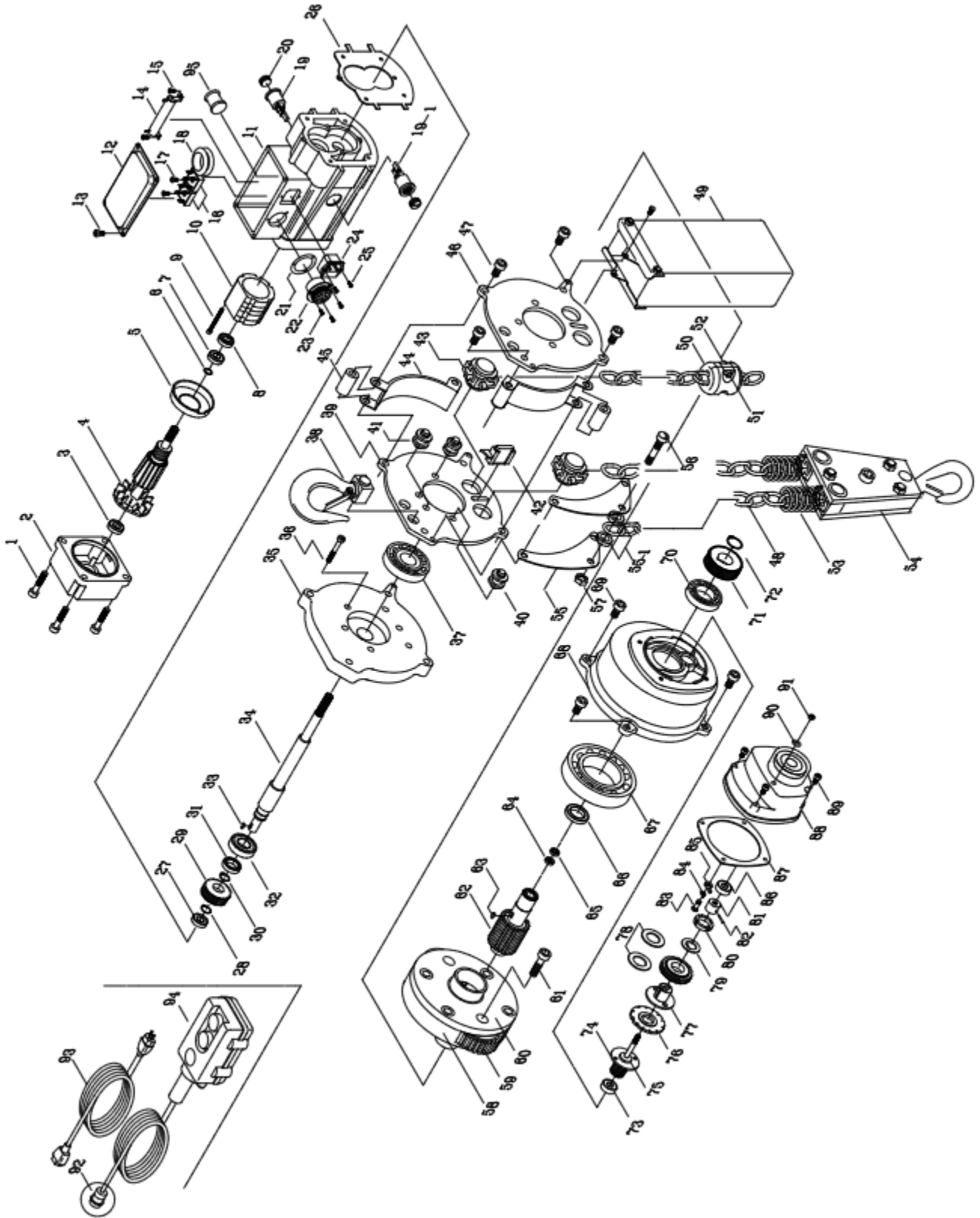

Table 11-1 PARTS LIST MODEL MH

ITEM	PART DESCRIPTION	Model MH-005 / MH-010		Model MH-020	
		Part No.	Qty	Part No.	Qty
1	SCREWS	MH001	4	MH001	4
2	MOTOR COVER	MH002	1	MH002	1
3	BEARING	MH003	1	MH003	1
4	ROTOR	MH004	1	MH004	1
5	AIR GUIDING IRON COVER	MH005	1	MH005	1
6	FIXING SPRING	MH006	1	MH006	1
7	BEARING	MH007	1	MH007	1
8	OIL SEAL	MH008	1	MH008	1
9	SCREWS	MH009	2	MH009	2
10	STATOR	MH010	1	MH010	1
11	MAIN BODY BASE	MH011	1	MH011	1
12	WIRING BOX	MH012	1	MH012	1
13	SCREWS	MH013	4	MH013	4
14	RESISTOR	MH014	1	MH014	1
15	SCREWS	MH015	2	MH015	2
16	BRIDGE TYPE RECTIFIER	MH016	2	MH016	2
17	SCREWS	MH017	2	MH017	2
18	RUBBER BAND	MH018	1	MH018	1
19	BASE OF CARBON BRUSH	MH019	2	MH019	2
19-1	CARBON	MH019-1	2	MH019-1	2
20	CARBON BRUSH COVER	MH020	2	MH020	2
21	RUBBER WASHER	MH021	1	MH021	1
22	CONTROL CABLE SOCKET	MH022	1	MH022	1
23	SCREWS	MH023	3	MH023	3
24	POWER SUPPLY INPUT TERM	MH024	1	MH024	1
25	SCREWS	MH025	2	MH025	2
26	INSULATED SHEET	MH026	1	MH026	1
27	BEARING	MH027	1	MH027	1
28	FIXING SPRING	MH028	1	MH028	1
29	FIRST SECTION GEAR	MH029	1	MH029	1
30	FIXING SPRING	MH030	1	MH030	1
31	BEARING	MH031	1	MH031	1
32	BEARING	MH032	1	MH032	1
33	KEY	MH033	1	MH033	1
34	FIRST SECTION GEAR SHAFT	MH034	1	MH034	1
35	GEAR COVER	MH035	1	MH035	1
36	SCREWS	MH036	6	MH036	6
37	BEARING	MH037	1	MH037	1
38	UPPER HOOK	MH038	1	MH038	1
39	LEFT MAIN BODY SHEET	MH039	1	MH039	1
40	CHAIN GUIDING WHEEL	MH040	2	MH040	2
41	UPPER CHAIN GUIDING WHEEL	MH041	2	MH041	2
42	CHAIN PAWL DEVICE	MH042	1	MH042	1
43	CHAIN GUIDER	MH043	2	MH043	2
44	MAIN BODY COVER	MH044	2	MH044	2
45	FIXING ROD OF MAIN BODY	MH045	4	MH045	4
46	RIGHT MAIN BODY SHEET	MH046	1	MH046	1
47	SCREWS	MH047	2	MH047	2
48	CHAIN	MH048	1	MH048	1
49	CHAIN BAG	MH049	1	MH049	1
50	CHAIN STOPPING BLOCK	MH050	1	MH050	1
51	SCREWS	MH051	2	MH051	2
52	NUTS, WASHER	MH052	2	MH052	2

Table 11-1 PARTS LIST MODEL MH

ITEM	PART DESCRIPTION	Model MH-005/ MH-010		Model MH-020	
		Part No.	Qty	Part No.	Qty
53	CHAIN GUIDING SPRING	MH053	1	MH053	1
54		See Table 11-2		See Table 11-3	
55		See Table 11-2		See Table 11-3	
56	SCREWS	MH056	2	MH056	1
57	NUTS, WASHER	MH057	2	MH057	1
58	CHAIN GUIDER	MH058	1	MH058	1
59	GEAR SHAFT	MH059	2	MH059	2
60	FIXING BASE OF GEAR SHAFT	MH060	1	MH060	1
61	SCREWS	MH061	4	MH061	4
62	THIRD SECTION GEAR SHAFT	MH062	1	MH062	1
63	KEY	MH063	1	MH063	1
64	OIL SEAL	MH064	1	MH064	1
65	BEARING	MH065	1	MH065	1
66	OIL SEAL	MH066	1	MH066	1
67	BEARING	MH067	1	MH067	1
68	GEAR REDUCE BOX OF SECOND LAYER	MH068	1	MH068	1
69	SCREWS	MH069	4	MH069	4
70	BEARING	MH070	1	MH070	1
71	THIRD SECTION GEAR	MH071	1	MH071	1
72	FIXING SPRING	MH072	1	MH072	1
73	BEARING	MH073	1	MH073	1
74	THIRD SECTION GEAR SHAFT	MH074	1	MH074	1
75	KEYLESS GEAR	MH075	1	MH075	1
76	PAWL BRAKE LINING	MH076	1	MH076	1
77	BRAKE DEPRESSOR (LOWER)	MH077	1	MH077	1
78	PRESS DISK TYPE SPRING	MH078	2	MH078	2
79	NUTS FIXING SHEET	MH079	1	MH079	1
80	TORQUE LIMITED NUTS	MH080	1	MH080	1
81	BRAKE DEPRESSOR (UPPER)	MH081	1	MH081	1
82	FIXNG PIN	MH082	1	MH082	1
83	CLICK FIXING BOLT	MH083	1	MH083	1
84	CLICK SPRING	MH084	1	MH084	1
85	CLICK	MH085	1	MH085	1
86	PRESS DISK TYPE SPRING	MH086	1	MH086	1
87	PACKING	MH087	1	MH087	1
88	FIRST LAYER GEAR BOX	MH088	1	MH088	1
89	SCREWS	MH089	4	MH089	4
90	WASHER	MH090	1	MH090	1
91	NUTS	MH091	1	MH091	1
92	CONTROL PLUG	MH092	1	MH092	1
93	POWER CABLE SET	MH093	1	MH093	1
94	CABLE SET OF CONTROL SWITCH	MH094	1	MH094	1
95	FUSE	MH095	1	MH095	1

Table 11-2 Part List Model MH-005 / MH-010			
ITEM	PART DESCRIPTION	Model MH-010	
		Part No.	Qty
54	LOWER HOOK SUSPENSION	MH054A	1
55	LOWER HOOK	MH055A	1

Table 11-3 Part List Model MH-020			
ITEM	PART DESCRIPTION	Model MH-020	
		Part No.	Qty
54	LOWER HOOK	MH054B	1
55	CHAIN SHEET IRON	MH055B	1

12 SPARE PARTS & PARTS LIST

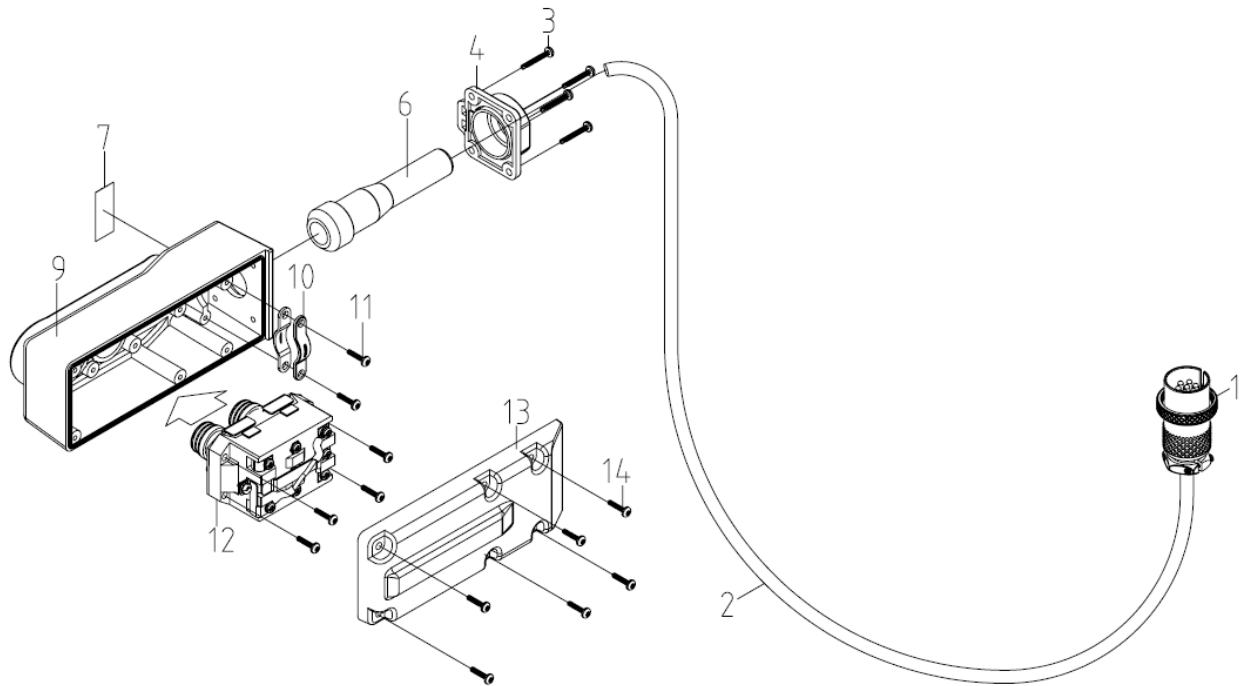

TABLE 12-1 PARTS LIST FOR PENDANT

ITEM NO.	PART DESCRIPTION	Part No.	QTY
1	CONNECTOR	PBS-1PH-1	1
2	SWITCH CABLE	PBS-1PH-2	1
3	SCREWS	PBS-1PH-3	4
4	PLASTIC COVER	PBS-1PH-4	1
6	TUBE	PBS-1PH-6	1
7	STICKER	PBS-1PH-7	1
9	PLASTIC COVER	PBS-1PH-9	1
10	SCREWS	PBS-1PH-10	2
11	SCREWS	PBS-1PH-11	2
12	INTERIOR CONNECTOR	PBS-1PH-12	1
13	PLASCTIC COVER	PBS-1PH-13	1
14	SCREWS	PBS-1PH-14	6

13 WIRING DIAGRAM: MH-005 / MH-010/ MH-020 Wiring Diagram

MH Series
MECHANICS HOIST

Wiring Diagram

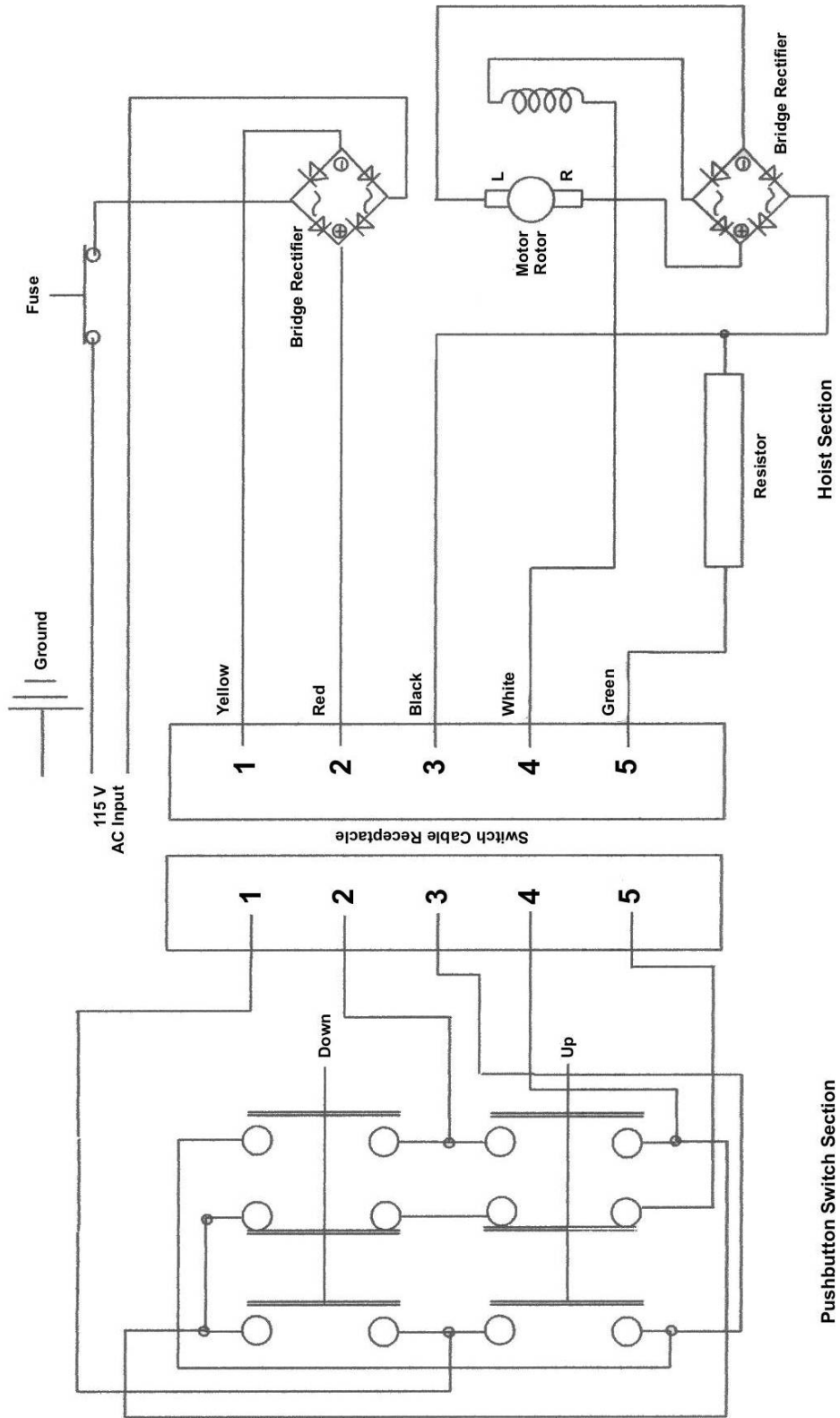

WARRANTY

Every hoist is thoroughly inspected and tested prior to shipment from the factory.

All products sold by ACI Hoist & Crane, Inc. are warranted to be free from defects in material and workmanship from date of shipment by ACI for a period of one (1) year.

The product must be used in accordance with manufacturer's recommendations and must not have been subject to abuse, lack of maintenance, misuse, negligence, or unauthorized repairs or alterations conducted by non-ACI Factory Authorized personnel.

Should any defect in material or workmanship occur during the above time period in any product, as determined by ACI's inspection of the product, ACI agrees, at its discretion, either to replace (not including installation) or repair the part or product free of charge and deliver said item F.O.B. ACI's place of business to the customer.

Customer must contact ACI to obtain a Return Authorization prior to shipping product for warranty evaluation. An explanation of the complaint must accompany the product. Product must be returned freight prepaid. Upon repair, the product will be covered for the remainder of the original warranty period. If it is determined there is no defect, or that the defect resulted from causes not within the scope of ACI's warranty, the customer will be responsible for the costs of returning the product.

ACI Hoist & Crane, Inc. disclaims any and all other warranties of any kind expressed or implied as to the product's merchantability or fitness for a particular application. ACI will not be liable for death, injuries to persons or property or for incidental, contingent, special or consequential damages, loss or expense arising in connection with the use or inability whatever, regardless of whether damage, loss or expense results from any act or failure to act by ACI, whether negligent or willful, or for any other reason.

WARNING

Alterations or modifications of equipment and use of non-factory repair parts can lead to dangerous operation and injury.

To avoid injury

- **Do not** alter or modify equipment.
- **Do not** use equipment to lift, support or otherwise transport people.
- **Do not** suspend unattended loads over people.