

BEAM CLAMP

OPERATING, MAINTENANCE & PARTS MANUAL FOR MODELS BC AND BCS



ACI Hoist & Crane
689 S.W. 7th Terrace
Dania, FL 33004
Phone: 954 -367-7116
Fax: 954-272-0334
www.ACIIHoist.com

Table of Contents

SECTION	PAGE
1 General Information.....	4
1.1 Beam Clamp Construction.....	4
2 Instruction for Safe Use of Beam Clamp.....	4
2.1 Using a Beam Clamp Safely.....	4
2.2 In-service inspection & Maintenance.....	4
3 Dimensions and Specification.....	5
3.1 Beam Clamp Dimensions & Specifications.....	5
3.2 Beam Clamp with Shackle Dimensions & Specifications.....	6
4 Spare Parts.....	7
4.1 Beam Clamp Parts List.....	7
4.2 Beam Clamp with Shackle Parts List.....	8
5 Warranty.....	8

1.0: GENERAL INFORMATION

This document provides information and maintenance of ACI clamps. Operators and persons maintaining the clamps should be familiar with this manual. Following the precautions, procedures and maintenance practices in this manual should ensure long and reliable operation.

People responsible for the installation operation, and or maintenance of the clamp equipment should be familiar with the American National Standard ANSI B30.20 for guidelines on the safe operation of trolleys. That document contains rules on inspection requirements and records that may be required by some of the regulatory agencies

1.1: CLAMP CONSTRUCTION

The clamps are designed for a lifting plate. Before installing, make sure that the load doesn't exceed the rated capacity of the clamp. The clamp should always be stored indoors. Never leave clamps exposed to the elements.

2.0: INSTRUCTIONS FOR THE SAFE USE OF BEAM CLAMPS

2.1: USING BEAM CLAMPS SAFELY:

1. Ensure that the beam clamp is of the correct capacity for the load being lifted and that the beam will not be damaged by localized overloading.
2. Ensure that the clamp is fitted correctly over the center of gravity to the item being lifted and will not be subject to side loading.
3. Before lifting a load, ensure that the clamp has been tightened and that the lifting appliance is fitted correctly into the eye of the clamp.

2.2: IN-SERVICE INSPECTION AND MAINTENANCE:

1. Ensure that beam clamps are kept clean and moving parts are lubricated.
2. Regularly inspect beam clamps for wear, damage, distortion, cracks, and any defects likely to cause a danger.

**If any of the above defects are found remove the beam clamp from service and refer to a competent person.

3.0: DIMENSIONS & SPECIFICATION

3.1 BEAM CLAMP DIMENSIONS & SPECIFICATIONS

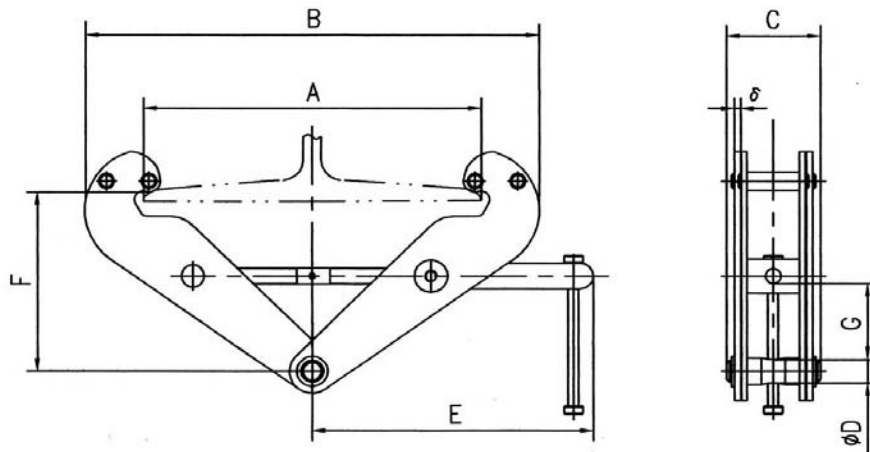

Model	BC-020	BC-040	BC-060	BC-100	BC-200	
Capacity (tons)	1	2	3	5	10	
Max Flange Thickness	7/8	7/8	1 1/2	1 1/2	1 3/4	
Flange width (in)	2.9-8.6	2.9-8.6	3.1-12.6	3.1-12.6	3.5-12.6	
Dimensions (in)	Max. A	10.20	10.20	13.90	13.90	14.40
	Min. B	7.10	7.10	9.30	9.30	12.60
	Max. B	14.17	14.17	19.3	19.3	19.88
	C	2.50	2.90	4.00	4.30	4.70
	D	0.20	0.23	0.31	0.39	0.47
	E	8.46	8.46	10.20	10.20	11.00
	Min. F	4.00	4.00	5.50	5.50	6.70
	Max. F	6.10	6.10	8.90	8.90	9.25
	Min. G	1.00	1.00	1.80	1.80	1.90
H	0.87	0.87	0.94	1.10	1.57	
Net weight (lb)	9.9	11	23.2	24.3	35.3	

3.2: BEAM CLAMP WITH SHACKLE DIMENSIONS & SPECIFICATIONS

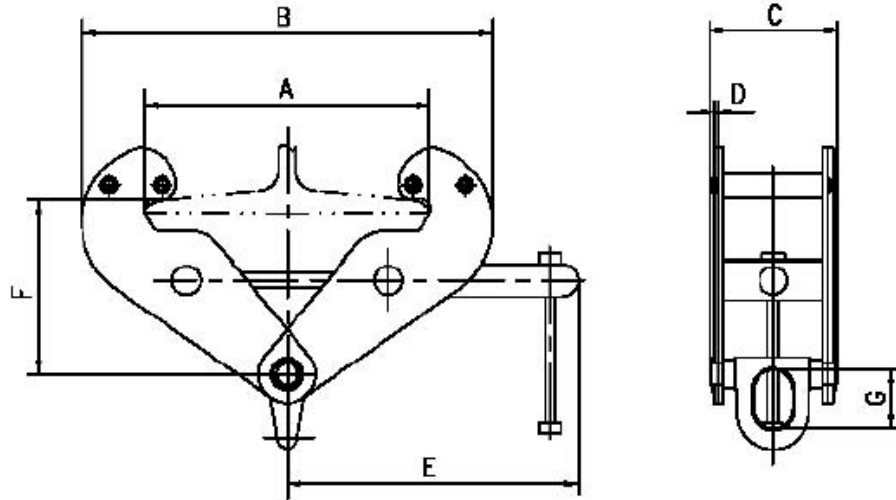

Model	BCS-020	BCS-040	BCS-060	BCS-100	BCS-200	
Capacity (tons)	1	2	3	5	10	
Max Flange Thickness	$\frac{7}{8}$	$\frac{7}{8}$	$1\frac{1}{2}$	$1\frac{1}{2}$	$1\frac{3}{4}$	
Flange width (in)	3"-9"	3"-9"	3.1"-12.6"	3.5"-12.6"	3.5"-12.6"	
Dimensions (in)	Max. A	11.18	11.18	14.37	14.37	14.09
	Min. B	7.09	7.09	8.66	8.66	9.84
	Max. B	14.76	14.76	19.6	19.6	20.2
	C	3.64	3.96	5.16	5.97	7.09
	D	0.02	0.24	0.31	0.39	0.47
	E	8.5	8.5	11.63	11.63	11.63
	Min. F	5.35	5.35	7.28	7.28	7.28
	Max. F	6.1	6.1	8.86	8.86	9.37
Min. G	1.77	1.77	2.28	2.28	3.54	
Net weight (lb)	9.9	12.1	20.9	25.3	41.9	

4.0: SPARE PARTS

EXPLODED VIEW: BEAM CLAMP

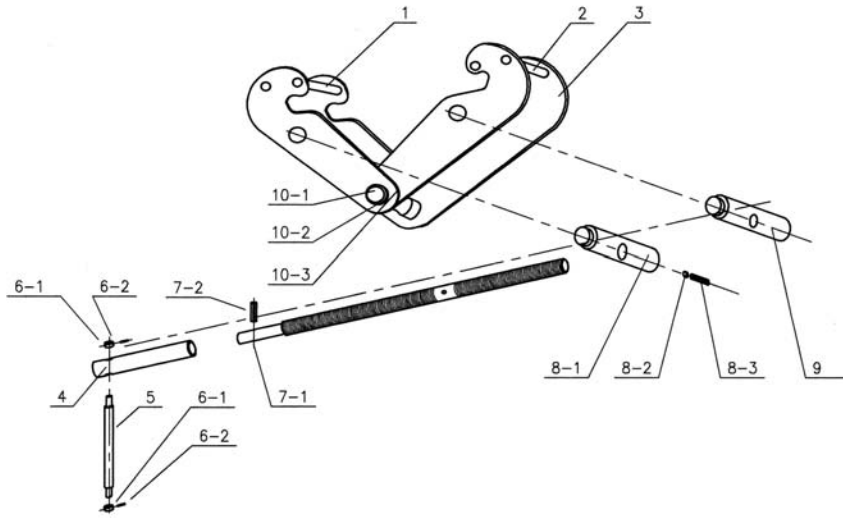

4.1: PARTS LIST

1. Stay	5. Lever Handle	7-2. Spring Straight Pin	9. Dexter Thread Spindle
2. Stay	6-1. Nut	8-1. Left Thread Spindle	10-1 Equalizer Pin
3. Side Plate	6-2. Spring Straight Pin	8-2. Washer	10-2.Washer
4.Lever Handle Link Cover	7-1. Screw Mandrel	8-3. Spring Straight Pin	10-3. Washer

EXPLODED VIEW: BEAM CLAMP WITH SHACKLE

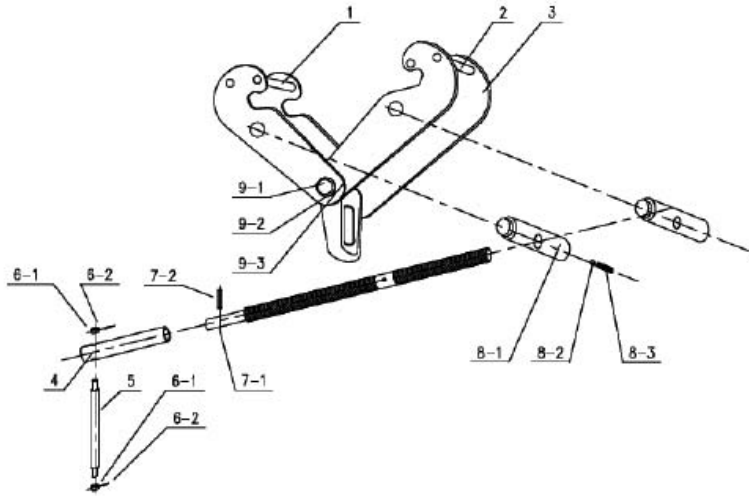

4.2: Parts List

1. Stay	5. Lever Handle	7-2. Spring Straight Pin	9-1. Equalizer Pin
2. Stay	6-1. Nut	8-1. Left Thread Spindle	9-2. Washer
3. Slide Plate	6-2. Spring Straight Pin	8-2. Washer	9-3. Washer
4. Lever Handle Link Cover	7-1. Screw Mandrel	8-3. Spring Straight Pin	

5.0: WARRANTY

WARRANTY

Every clamp is thoroughly inspected and tested before it is shipped from the factory. If any problem develops within one-year return the complete clamp prepaid to the factory. If an inspection reveals that the problem is caused by defective workmanship or material, repairs will be made without charge and the clamp will be returned, transportation prepaid.

This warranty does not cover: (a) deterioration caused by normal wear, abuse, eccentric or side loading, overloading, chemical or abrasive actions, improper maintenance or excessive heat; (b) problems resulting from repairs, modifications or alterations made by people other than factory or ACI representative; (c) the clamp has been abused or damaged due to an accident; (4) repair parts or accessories other than ACI equipment are used on the clamp. Equipment and accessories not of the seller's manufacture are warranted only to extent that they are warranted by the manufacturer.

EXCEPT AS STATED HERE, ACI MAKES NO OTHER WARRANTIES, EXPRESS OR IMPLIED, INCLUDING WARRANTIES FOR A PARTICULAR PURPOSE.