



Push and Gear Trolleys Models PT and GT

Push Trolleys



Geared Trolleys



Features

- Capacity range from 0.25 to 20 ton
- Easily Adjustable to fit a wide range of beam widths simply by adjusting the number of collars.
- Anti-friction precision type ball bearings.
- High grade sealed ball bearings with a minimum B10 bearing life of 3,000 hours.
- Anti-tilt and anti-drop devices are standard.
- Forged steel wheels hardened to a minimum of 425 Brinell are made to fit any shape of the beam.
- Light weight robust construction.
- Zinc plated hand chain as standard for gear trolley.
- Double row bearings with combination radial and thrust.
- Easy to install with minimum headroom.
- Easy to replace worn parts.
- Minimum maintenance.

Trolley Construction

The trolleys are designed for use with most hoists. Before installing, verified that the supporting structure is able to support the weight of the load, hoist, and trolley with a safe factor.



689 SW 7th Terrace
Dania, FL 33004
(954) 367-6116
WWW.ACIHOIST.COM

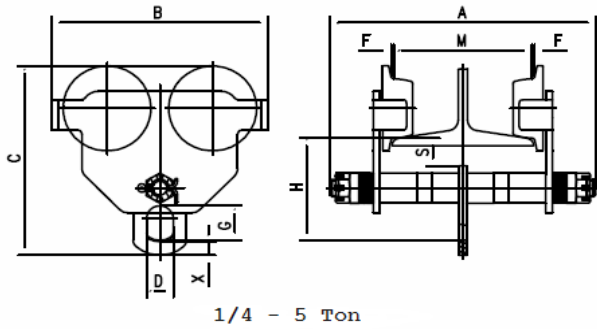

1/4 - 5 Ton

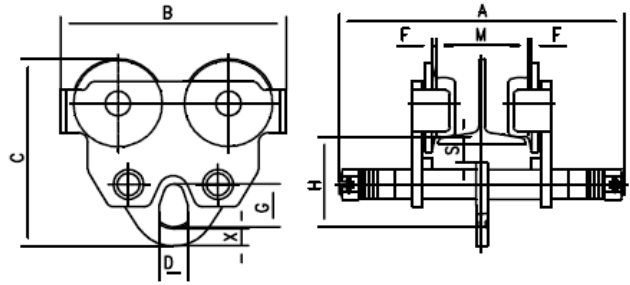

10 - 20 Ton

PUSH TROLLEY SPECIFICATIONS

Model		PT-005-S	PT-010-S	PT-020-S	PT-040-S	PT-060-S	PT-060-L	PT-100-S	PT-100-L	PT-200-L	PT-400-L
Rated capacity (tons)		¼	½	1	2	3	3	5	5	10	20
Min. radius of curve (ft.)		2.6	2.6	3.3	3.6	4.3	4.3	4.6	4.6	6.6	11.5
Diameter of wheel (in.)		2.3	2.3	2.9	3.5	4.3	4.3	4.8	4.8	5.9	7.9
Dimensions (in.)	A	9.6	9.6	12.2	12.9	13.5	17.5	14	18	20.1	23.8
	B	7.6	7.6	9.7	10.9	13.1	13.1	14.8	14.8	16.7	23.8
	C	7.4	7.4	8.7	10.3	12.2	12.2	13.9	13.9	15.6	19.6
	H	4.1	4.1	4.9	5.9	6.7	6.7	7.7	7.7	7.5	9.2
	S	1.2	1.2	1.5	1.5	1.6	1.6	1.7	1.7	1.8	2.3
	D	1	1	1.2	1.5	1.6	1.6	2	2	2.8	3.7
	X	0.63	0.63	0.63	0.75	0.88	0.88	1.13	1.13	2	3.5
	G	1.3	1.3	1.6	2	2.5	2.5	3	3	4.3	5.3
F	0.10 - 0.12									0.10 - 0.14	
I-beam width range (in.)	M	2.0 - 6.0	2.0 - 6.0	2.5 - 8.0	3.5 - 8.0	4.0 - 8.0	4.0 - 12.0	4.5 - 8.0	4.5 - 12.0	4.9 - 12.0	5.4 - 12.0
Net weight (lbs)		15.4	15.4	26.5	48.5	66	70	95	100	205	518

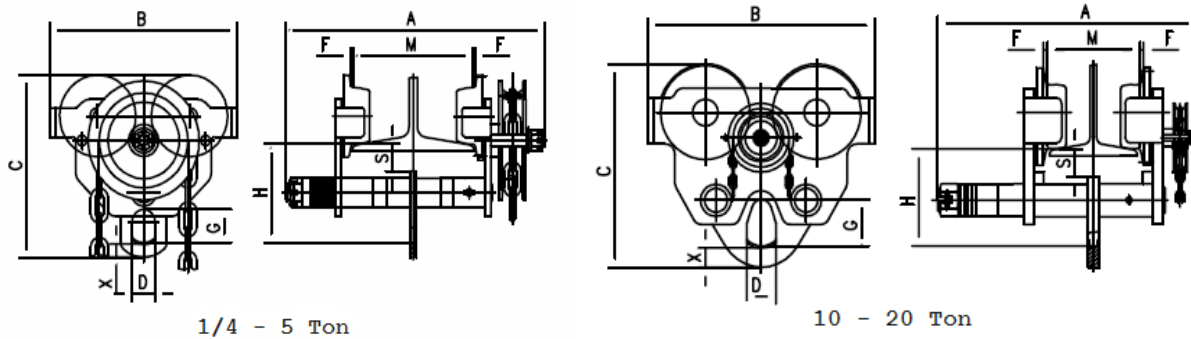

GEAR TROLLEY SPECIFICATIONS

Model		GT-005-S	GT-010-S	GT-020-S	GT-040-S	GT-060-S	GT-060-L	GT-100-S	GT-100-L	GT-200-L	GT-400-L
Rated capacity (tons)		¼	½	1	2	3	3	5	5	10	20
Standard Hand Chain Drop		8 ft.									
Min. radius of curve (ft.)		3.3	3.3	3.3	3.6	4.3	4.3	4.6	4.6	6.6	11.5
Diameter of wheel (in.)		2.9	2.9	2.9	3.5	4.3	4.3	4.8	4.8	5.9	7.9
Dimensions (in.)	A	13.3	13.3	13.3	13.7	14.3	18.3	14.7	18.7	20.1	23.8
	B	9.7	9.7	9.7	10.9	13.1	13.1	14.8	14.8	16.7	23.8
	C	8.7	8.7	8.7	10.3	12.2	12.2	13.9	13.9	15.6	19.6
	H	4.9	4.9	4.9	5.9	6.7	6.7	7.7	7.7	7.5	9.2
	S	1.5	1.5	1.5	1.5	1.6	1.6	1.7	1.7	1.8	2.3
	D	1.2	1.2	1.2	1.5	1.6	1.6	2.0	2.0	2.8	3.7
	X	0.63	0.63	0.63	0.75	0.88	0.88	1.13	1.13	2.00	3.5
	G	1.6	1.6	1.6	2.0	2.5	2.5	3.0	3.0	4.3	5.3
	F	0.10 - 0.12							0.10 - 0.14		
I-beam width range (in.)	M	2.5 - 8.0	2.5 - 8.0	2.5 - 8.0	3.5 - 8.0	4.0 - 8.0	4.0 - 12.0	4.5 - 8.0	4.5 - 12.0	4.9 - 12.0	5.4 - 12.0
Net weight (lbs.)		31	31	42	64	88	95	108	113	227	540