



Lifting Magnet Model PML



Features

- Lifting Capacity range from 660 to 4400 lbs
- One piece suspension frame
- Low effort to lift maximum load
- A great concentration of power with ASME B30.20 rating
- Fully machined lift wheel
- On & off handle lock. The handle controls an inner magnetic system for safe and easy operation.
- Without power, there is NO risk in the condition of no electrical source
- Use of high-energy magnetic material ensures a compact, lightweight and durable design
- Simple locking witch handle enable safe, quick and easy one-handle operation
- Very low residual magnetism for quick and efficient handling of work pieces
- Large shackle top fitting for easy attachment of slings and rigging
- V slot in bottom lifting face for lifting rounds as well as flats
- Clear markings of duration for varying shaped work pieces, lifting conditions, air gap, steel thickness, etc.
- Individually fully proof load tested by ACI Hoist & Crane.
- The Maximum operation temperature is 80°C.

Lifting Magnet Construction

The Lifting Magnet has strong magnetic path produced by Nd-Fe-B magnetic materials. The 'On' and 'Off' magnetic path is controlled by turning the handle manually. It uses magnet as power. In essence, lifting power will never weaken.

An external power source is not required which means that Lifting Magnets can be used virtually anywhere. The Lifting Magnet is mainly used for connecting component during lifting and handling operation. They can elevate moving iron block, cylindrical and other magnetic material.

It is very convenient for functions such as loading, unloading, and moving. In essence, the ideal usage of a Lifting Magnet is handling steel plates, die castings, forgings, etc. They eliminate the need for using a clamping tool, slings, or chains. They are easy for operation, safe in handling, lightly and ingeniously structured. Hence, they are widely used as hoisting devices in factories, docks, warehouses, and transportation industries. By using them, you can improve your working conditions and increase your working efficiency.



689 S.W. 7th Terrace
Dania, FL 33004
(954) 367-6116
WWW.ACIHOIST.COM

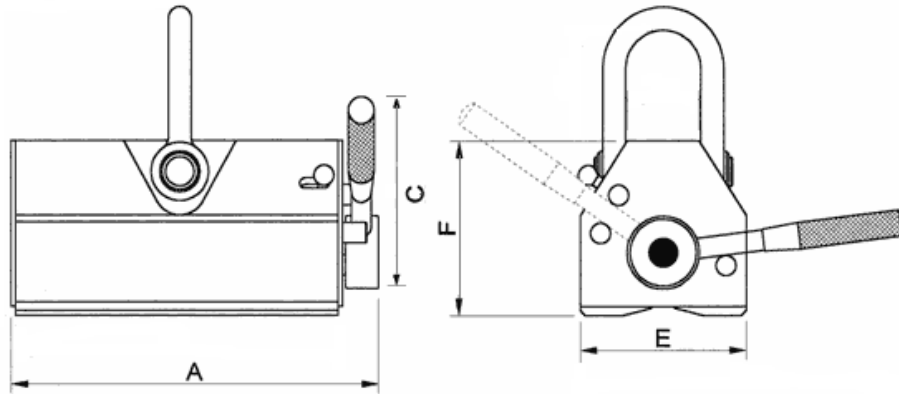

Model	PML-3	PML-6	PML-10	PML-20
Lifting Capacity (lbs)	660	1320	2200	4400
Max rated load for round steel (lbs)	297	594	990	1980
Max rated load for flat steel (lbs)	660	1320	2200	4400
Max "Breakaway Force" (lbs)	2315	4629	7716	15432
Distance (in)	A	6.4	9.1	10.2
	C	5.9	7.7	11.2
	E	3.6	4.8	6.9
	F	3.5	4.6	6.4
Net weight (lbs)	22	53	110	275

SAFETY CURVE CAPABILITIES

ACTUAL CAPACITY VALUE

The lift value of the Lifting Magnet is affected and reduced by the following factors: in all applications:

Thickness (see Table 1 below)	Air Gap (see Table 2 below)	Carbon Composition	Round Bar or Pipe	Sheet
The lift mild steel plate: <i>refer to Table 1 and Chart 1 below.</i>	An Air Gap between the Lifting Magnet and the steel load produced by paint, dirt, roughness, or uneven surface of a load: <i>refer to Table 2 below.</i>	When there is a lift of high Carbon steel, the lift value will be 30% less. If lifting a cast iron, lift value will be 50% less.	A Round bar must contact the V shape slot at the bottom of the Lifting Magnet with the two lines. Also, the actual capacity value will be approximately 40% of that plate. When lifting pipes, its thickness should also count. The actual capacity value is also affected by the diameter of the round load.	A large but thin steel sheet can be bended in an arc profile and then peeled off when lifted, even though it is light. When lifting a sheet from a stack, the magnetic flux may penetrate through the sheet and cling lower pieces. This is an unsafe condition.

STEEL THICKNESS

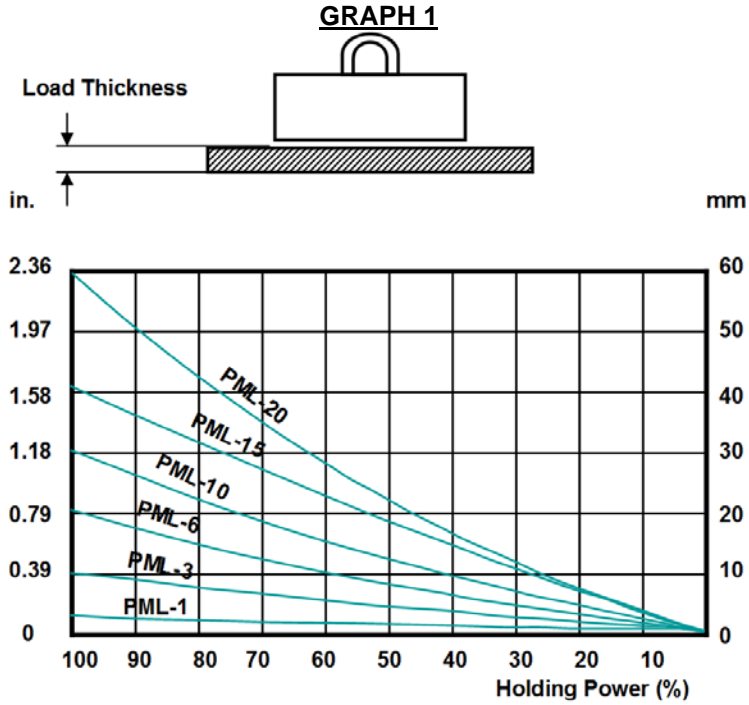

TABLE 1: ACTUAL CAPACITY

PML-3: Nominal Capacity 660 lbs		
Minimum Thickness (in)	Holding power	Actual capacity (lb)
1/8	40	264
1/4	70	462
3/8 & up	100	660

PML-6: Nominal Capacity 1320 lbs		
Minimum Thickness (in)	Holding power	Actual capacity (lb)
1/8	20	264
1/4	40	528
3/8	60	792
5/8	85	1122
3/4	95	1254
1 & up	100	1320

PML-10: Nominal Capacity 2200 lbs		
Minimum Thickness (in)	Holding power	Actual capacity (lb)
1/8	15	330
1/4	30	660
3/8	40	880
5/8	65	1430
3/4	70	1540
1	87	1914
1 1/4 & up	100	2200

PML-20: Nominal Capacity 4400 lbs		
Minimum Thickness (in)	Holding power	Actual capacity (lb)
1/8	10	440
1/4	20	880
3/8	25	1100
5/8	40	1760
3/4	45	1980
1	55	2420
1 1/4	65	2860
1 1/2	75	3300
2	92	4048
2 1/4	98	4312
2 1/2 & up	100	4400

AIR GAP

GRAPH 2

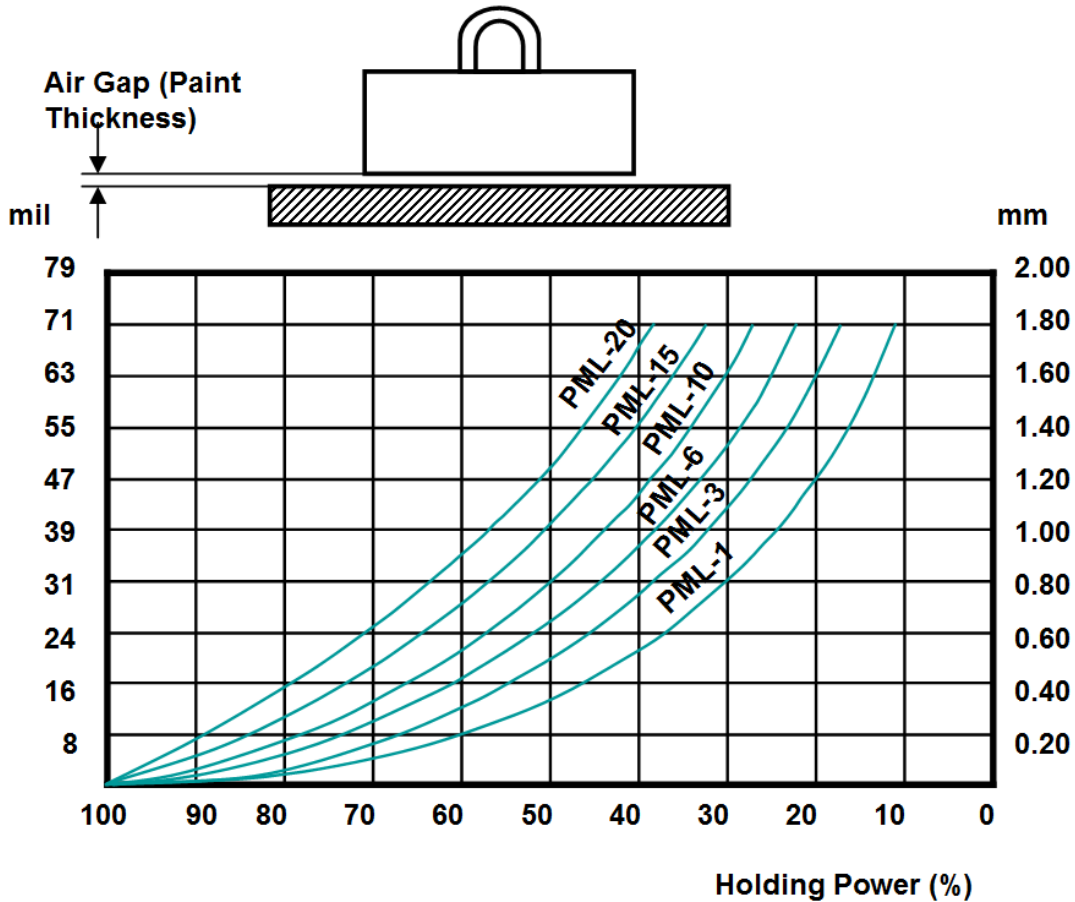

1 mil = 0.001 inch
 Standard paint thickness is 5-8 mils per coat

Formula for Range of Lifting Capacity is:

$$\text{Actual Capacity} = \text{Nominal Capacity (lbs)} \times \text{T Factor (\%)} \times \text{A Factor (\%)}$$

T Factor = Thickness Holding Power (%)

A Factor = Air Gap Holding Power (%)

Example: PML-600 rated lifting power is 1,320 lbs.

3/8" Thickness Plate means T Factor (%) = 60%

(Note: see Graph 1)

1)

Standard Paint Thickness is 8 mils mean A Factor (%) = 90%

(Note: see Graph 2)

$$\text{Actual Capacity} = 1320 \text{ (lbs)} \times 60 \text{ (\%)} \times 75 \text{ (\%)}$$

$$\text{Actual Capacity} = 594.0 \text{ lbs}$$



Please consider the Air Gap when choosing your Lifting Magnet