



Beam Clamps Model BC & BCS

Features

- Capacity range from 1 to 10 ton.
- Robust all steel construction with safety operation.
- Easy to install with minimum headroom.
- Compact size with light weight.
- Special clamp jaw design distributes load away from edge.
- Threaded screw fits securely on a wide range of flange width and beam sizes.
- Easy to replace wear parts.



Clamp Construction

The clamps are designed for lifting plate. Before installing, make sure that the load doesn't exceed the rated capacity of the clamp. Clamp should always be stored indoor. Never leave them exposed to the elements.



689 SW 7th Terrace
Dania, FL 33004
(954) 367-6116
www.ACIHoist.com

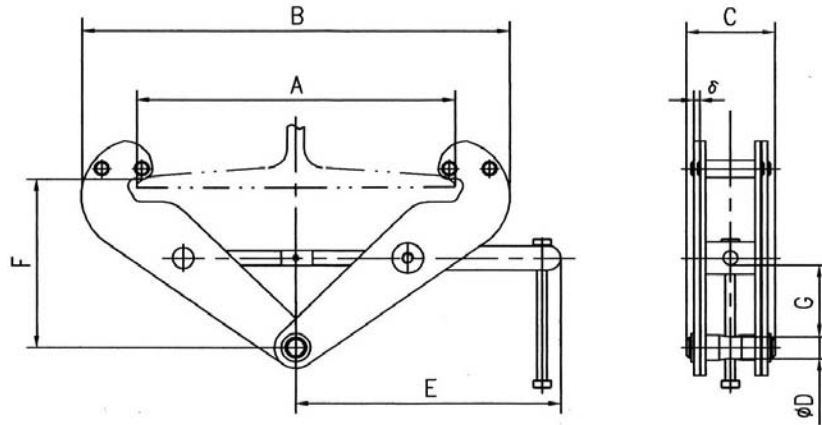

Model	BC-020	BC-040	BC-060	BC-100	BC-200	
Capacity (tons)	1	2	3	5	10	
Flange width (in)	2.9-8.6	2.9-8.6	3.1-12.6	3.1-12.6	3.5-12.6	
Max Flange Thickness	$\frac{7}{8}$	$\frac{7}{8}$	$1\frac{1}{2}$	$1\frac{1}{2}$	$1\frac{3}{4}$	
Dimensions (in)	Max. A	10.20	10.20	13.90	13.90	14.40
	Min. B	7.10	7.10	9.30	9.30	12.60
	Max. B	14.17	14.17	19.3	19.3	19.88
	C	2.50	2.90	4.00	4.30	4.70
	D	0.20	0.23	0.31	0.39	0.47
	E	8.46	8.46	10.20	10.20	11.00
	Min. F	4.00	4.00	5.50	5.50	6.70
	Max. F	6.10	6.10	8.90	8.90	9.25
	Min. G	1.00	1.00	1.80	1.80	1.90
H	0.87	0.87	0.94	1.10	1.57	
Net weight (lb)	9.9	11	23.2	24.3	35.3	

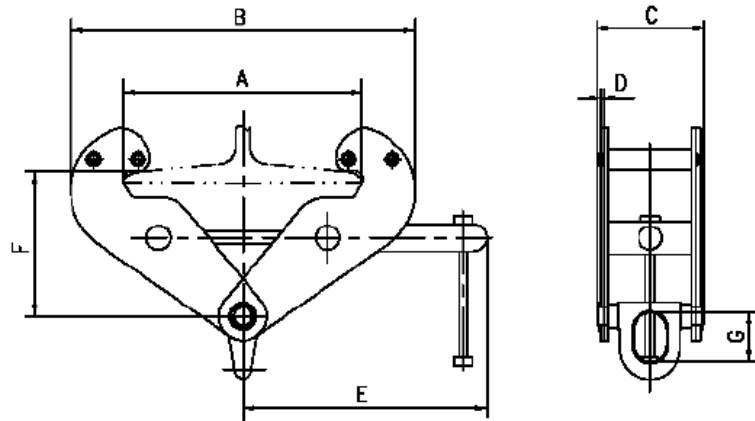

Model	BCS-020	BCS-040	BCS-060	BCS-100	BCS-200	
Capacity (tons)	1	2	3	5	10	
Max Flange Thickness	$\frac{7}{8}$	$\frac{7}{8}$	1½	1½	1¾	
Flange width (in)	3"-9"	3"-9"	3.1"-12.6"	3.5"-12.6"	3.5"-12.6"	
Dimensions (in)	Max. A	11.18	11.18	14.37	14.37	14.09
	Min. B	7.09	7.09	8.66	8.66	9.84
	Max. B	14.76	14.76	19.6	19.6	20.2
	C	3.64	3.96	5.16	5.97	7.09
	D	0.02	0.24	0.31	0.39	0.47
	E	8.5	8.5	11.63	11.63	11.63
	Min. F	5.35	5.35	7.28	7.28	7.28
	Max. F	6.1	6.1	8.86	8.86	9.37
Min. G	1.77	1.77	2.28	2.28	3.54	
Net weight (lb)	9.9	12.1	20.9	25.3	41.9	