

Lever Hoist Dimensions & Specifications

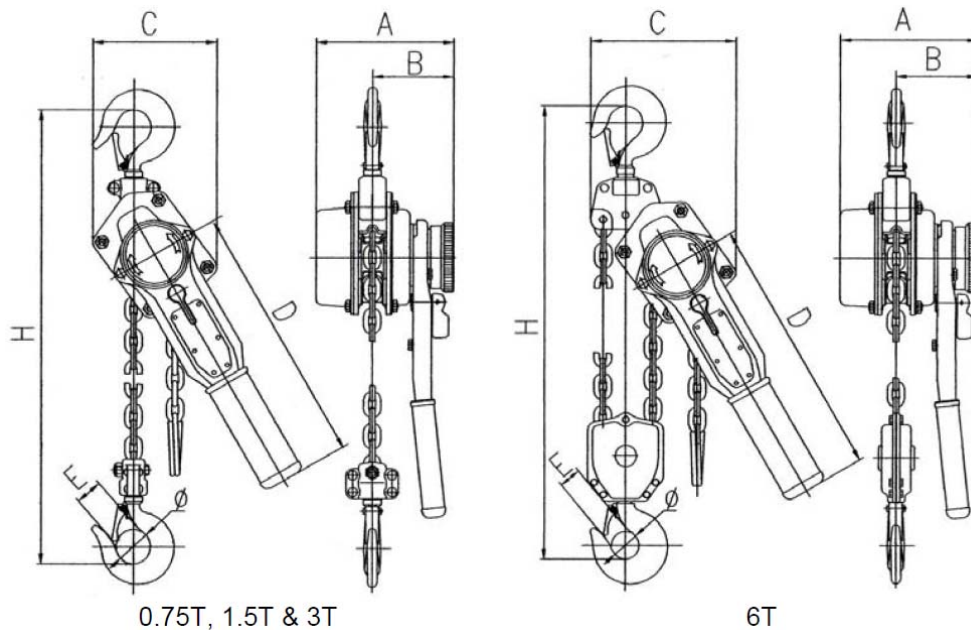

Model	LH-015	LH-030	LH-060	LH-120
Capacity (Tons)	¾	1 ½	3	6
No. of columns of load chain	1	1	1	2
Load Chain Diameter (in)	0.24	0.31	0.40	0.40
Handle pull rated loads (lbs)	60	66	75	83
Distance (in)	A	5.83	6.81	7.87
	B	3.43	3.9	4.41
	C	5.2	5.71	7.83
	D	10.94	14.88	15.28
	E	1.1	1.3	1.6
	O	1.4	1.67	1.97
	H	13	15.7	20.5
Net Weight (lbs) for 5 ft. lift	15.21	24	45.6	62.0
Packing measurement (in)	15 x 5 x 6.7	18.9 x 5.1 x 7.9	21.8 x 7.3 x 8.9	21.8 x 7.9 x 8.9
Extra weight per feet of extra lift (lbs)	0.53	0.94	1.48	2.96