

PLATE CLAMPS (VERTICAL & HORIZONTAL LIFTING CLAMPS)

OPERATING, MAINTENANCE, & PARTS MANUAL



Table of Contents

SECTION	PAGE
1 General Information.....	4
1.1 Plate Clamp Construction.....	4
2 Precaution While Operation.....	4
2.1 Preparations for Use.....	4
2.2 Warnings.....	4
3 Routine Care: Inspections & Maintenance.....	4
4 Plate Clamp Specification.....	5-6
5 Spare Parts.....	7-8
5.1 Parts List.....	7
5.2 Parts List.....	8
6 Warranty.....	8

1.0: GENERAL INFORMATION

This document provides information and maintenance of ACI clamps. Operators and persons maintaining the clamps should be familiar with this manual. Following the precautions, procedures and maintenance practices in this manual should ensure long and reliable operation.

People responsible for the installation operation, and or maintenance of the clamp equipment should be familiar with the American National Standard ANSI B30.20 for guidelines on the safe operation of trolleys. That document contains rules on inspection requirements and records that may be required by some of the regulatory agencies.

1.1: CLAMP CONSTRUCTION

The clamps are designed for a lifting plate. Before installing, make sure that the load doesn't exceed the rated capacity of the clamp. The clamp should always be stored indoors. Never leave clamps exposed to the elements.

2.0: PRECAUTIONS WHILE OPERATING

2.1: PREPARATION FOR USE

Clamps used for different application should be stored in separate places. Extra care must be taken when lifting plates of less then 20% rated jaw capacity.

2.2: WARNINGS

- Inspect clamps before use.
- Do not suspend loads over people.
- Do not overload.
- Do not move unbalanced load.

To avoid injury and/or property damage, the clamp(s) should be inspected periodically.

3.0: ROUTINE CARE: INSPECTION AND MAINTENANCE

The clamp(s) must be inspected periodically for wear and cracks on the welded area. The clamp(s) should be inspected once a week. The clamp(s) should be visually inspected for the following conditions:

- Wear on cam, swivel jaw, and other parts.
- Condition of the opening.
- Lose or worn nuts and bolts.

Clamps that you stopped using for safety reasons, should be clearly marked as defective and stored separately.

4.0: PLATE CLAMPS SPECIFICATIONS

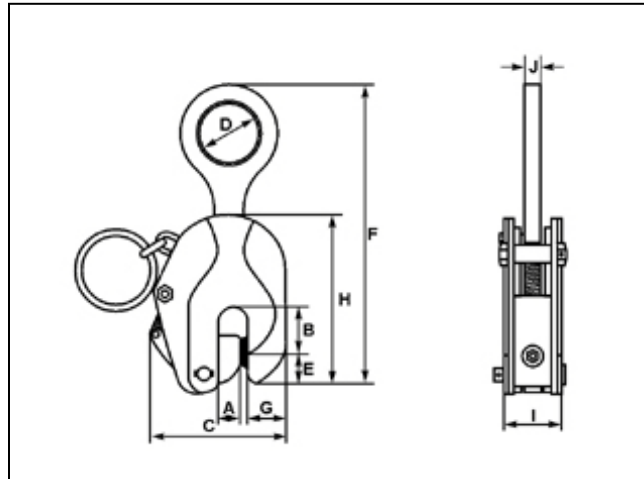

Models	VLC-020	VLC-040	VLC-060	VLC-100	
Lifting capacity(tons)	1	2	3	5	
Jaw opening (in)	0 - 0.9	0 - 1.2	0 - 1.4	0 - 2	
Dimensions (in)	A	0.9	1.4	1.6	2
	B	1.4	1.8	2	2.3
	C	4.9	6.1	6.9	8.6
	D	2	2.4	2.4	2.6
	E	0.9	1.2	1.4	1.6
	F	8.7 - 10.2	9.8 - 11.6	11.7 - 14.1	13.9 - 16.5
	G	1.2	1.5	1.6	2.4
	H	6.1	7.5	8.9	10.6
	I	2	2.4	2.7	3
J	0.6	0.7	0.8	0.9	
Net weight (lb)	7.9	13.2	20.3	36.4	

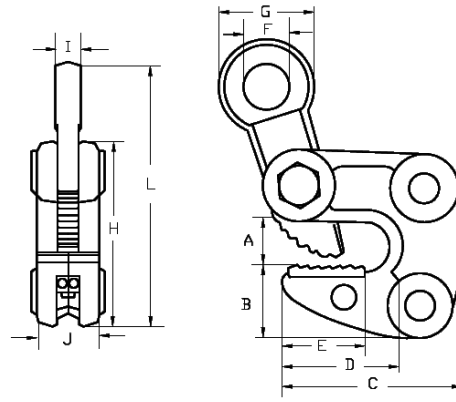

Models		HLC-020	HLC-040
Lifting Capacity (tons)		1	2
Plate	Thickness (in)	.1-.7	.1-.9
Dimensions (in)	A	0.9	1.3
	B	1.4	1.8
	C	4	5.1
	D	2.5	3.3
	E	1.7	2.2
	F	2.8	3.6
	G	1.8	2.2
	H	3.9	5.2
	I	0.5	0.6
	J	1.3	1.6
L	6.5	9.3	
Net Weight (lbs)		4.4	10.1

5.0: SPARE PARTS: EXPLODED VIEW

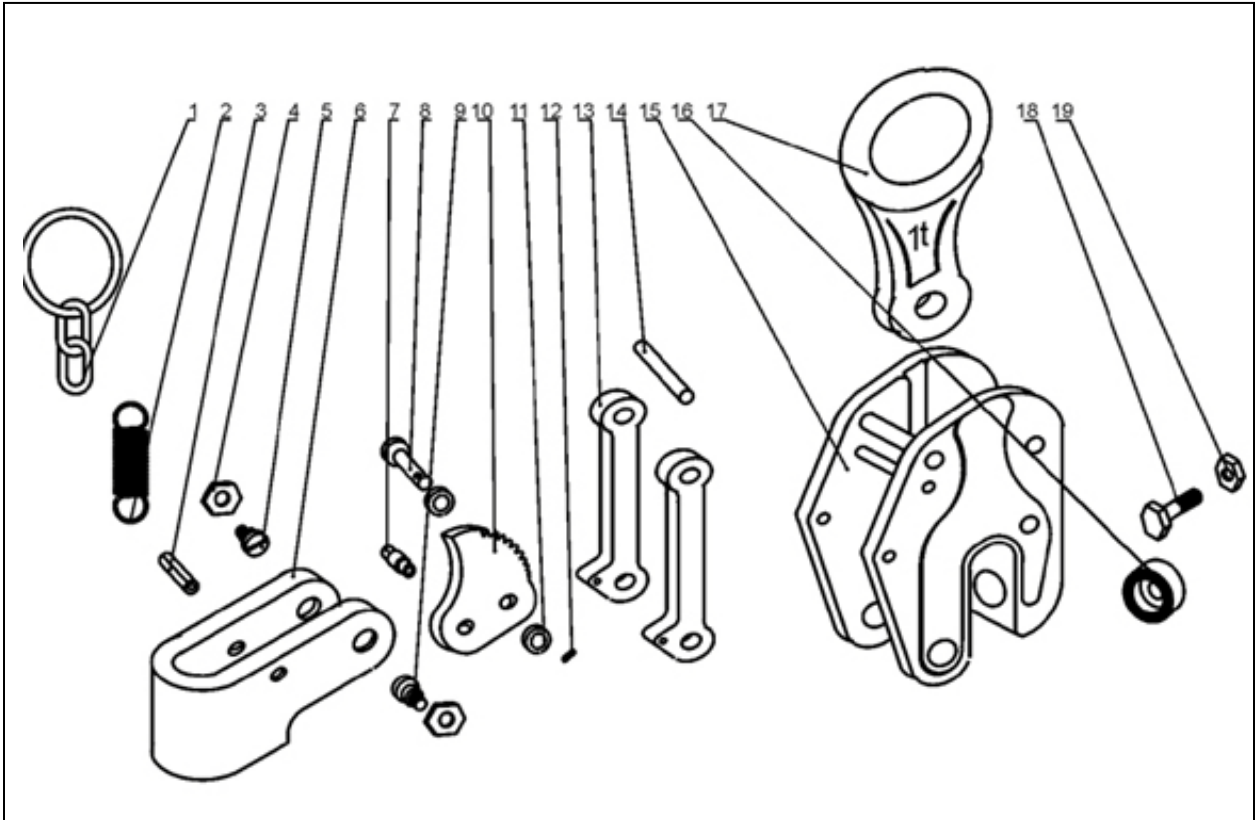

5.1: PARTS LIST

1. Pulling ring	6. Safety latch	11. Washer	16. Jaw holder
2. Safety latch	7. Link pin	12. Spring pin	17. Lift ring
3. Spring pin	8. Jaw shaft	13. Link shoulder	18. Bolt
4. Nut	9. Bolt	14. Shaft for link shoulder	19. Nut
5. Bolt	10. Jaw	15. Plate assembly	

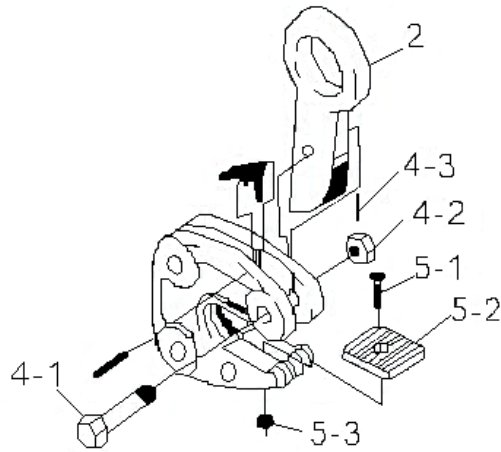

5.2: PARTS LIST

2	Cam
4	4.1 Support bolt for cam
	4.2 Support nut for cam
	4.3 Spring pin
5	5.1 Pad
	5.2 Bolt and nut for pad
Spare parts come in sets, not by individual units.	

6.0: WARRANTY

WARRANTY

Every clamp is thoroughly inspected and tested before it is shipped from the factory. If any problem develops within one-year return the complete clamp prepaid to the factory. If an inspection reveals that the problem is caused by defective workmanship or material, repairs will be made without charge and the clamp will be returned, transportation prepaid.

This warranty does not cover: (a) deterioration caused by normal wear, abuse, eccentric or side loading, overloading, chemical or abrasive actions, improper maintenance or excessive heat; (b) problems resulting from repairs, modifications or alterations made by people other than factory or ACI representative; (c) the clamp has been abused or damaged due to an accident; (4) repair parts or accessories other than ACI equipment are used on the clamp. Equipment and accessories not of the seller's manufacture are warranted only to extent that they are warranted by the manufacturer.

EXCEPT AS STATED HERE, ACI MAKES NO OTHER WARRANTIES, EXPRESS OR IMPLIED, INCLUDING WARRANTIES FOR A PARTICULAR PURPOSE.