

PUSH TROLLEY & GEAR TROLLEY

OPERATING, MAINTENANCE & PARTS MANUAL

PUSH TROLLEY



GEAR TROLLEY



Table of Contents

| SECTION | PAGE |
|--|-------|
| 1 General Information..... | 4 |
| 1.1 Trolley Construction..... | 4 |
| 2 Preparation for Use..... | 4-5 |
| 2.1 Precautions While Operating..... | 4 |
| 2.1.1 Terms & Summary..... | 4 |
| 2.1.2 Danger, Warning, Caution & Notice..... | 4 |
| 2.2 Warning Tags & Labels..... | 5 |
| 2.3 Routine Care, Inspection, & Maintenance..... | 5 |
| 3 Inspection before Initial Use..... | 5-6 |
| 3.1 Installation..... | 5 |
| 3.2 Mounting Location..... | 6 |
| 3.3 Pre-Operational Checks & Trial Operations..... | 6 |
| 4 Operation..... | 6 |
| 4.1 Trolley Controls..... | 6 |
| 5 Inspection..... | 6-8 |
| 5.1 General Information..... | 6 |
| 5.2 Service & Frequency Information..... | 7 |
| 5.2.1 Service Information..... | 7 |
| 5.2.2 Frequency/Daily Inspections..... | 7 |
| 5.2.3 Periodic Inspections..... | 7 |
| 5.3 Occasionally Used Trolley..... | 8 |
| 5.4 Inspection Methods & Criteria..... | 8 |
| 6 Maintenance & Handling..... | 9 |
| 6.1 Lubrication..... | 9 |
| 6.2 Storage..... | 9 |
| 6.3 Outdoor Installation..... | 9 |
| 7 Dimensions and Specification..... | 10-11 |
| 7.1 Push Trolley..... | 10 |
| 7.2 Gear Trolley..... | 11 |
| 8 Spare Parts: Exploded View..... | 12 |
| 8.1 Gear Trolley..... | 12 |
| 8.2 Push Trolley..... | 12 |
| 8.3 Parts List..... | 13 |
| 9 Warranty..... | 13 |

1.0: GENERAL INFORMATION

This document provides information and maintenance of ACI push and geared trolley. Operators and persons maintaining the trolley should be familiar with this manual. Following the precautions, procedures and maintenance practices in this manual should ensure long and reliable operation.

People responsible for the installation operation, and or maintenance of the trolley equipment should be familiar with the American National Standard ANSI B30.11 for guidelines on the safe operation of trolleys. That document contains rules on inspection requirements and records that may be required by some of the regulatory agencies.

1.1: TROLLEY CONSTRUCTION

The trolleys are designed for use with most hoists. Before installing, verified that the supporting structure is able to support the weight of the load, hoist, and trolley with a safe factor.

2.0: PREPARATION FOR USE

Measure the actual width of the beam. Assemble the required number of spacer washers equally to the inside of the trolley side plates so the dimension of the trolley wheel flanges is about $\frac{1}{8}$ of inch greater than the width of the beam. Loosely assemble the gear case, equalizer pin, lifting ring, spacer washers and hex nuts. Slacken off the hanger pin nuts and spread the side plates so the wheels can be slip peed up over the runaway beam. Screw the nuts firmly against the all four washers. Apply a light load to the suspension plate to ensure that all four wheels contact the beam flange. Then tighten the inside nuts firmly and secure them by firmly tightening the outside nuts to lock the nuts in positions.

2.1: PRECAUTIONS WHILE OPERATING

2.1.1: TERMS & SUMMARY

This manual provides important information for personnel involved with the installation, operation, and maintenance of Trolley. Although you may be familiar with trolley or similar equipment, it is strongly recommended that you read this manual before installing, operating or maintaining the product.

2.1.2: DANGER, WARNING, CAUTION & NOTICE

Throughout this manual, there are steps and procedures that can present hazardous situations. The following signals words are used to identify the degree or level of hazard seriousness.



Danger indicates an imminently hazardous situation which, if not avoided, **will** result in **death or serious** injury and property damage.



Warning indicates an imminently hazardous situation which, if not avoided, **could** result in **death or serious** injury and property damage.



Caution indicates a potentially hazardous situation which, if not avoided, **may** result in **minor or moderate** injury or property damage.



Notice is used to notify people of installation, operation or maintenance information which is important but not directly hazard related

2.2: WARNING TAG & LABELS

Read and obey all warnings for this product to avoid injury and/or property damage.

1. **ALWAYS** read owner's manual and safety instructions
2. **NEVER** lift more than rated load.
3. **NEVER** lift or transport loads over or near people.
4. **DO NOT** suspend loads over people.
5. **DO NOT** overload.
6. **DO NOT** side load.

2.3: ROUTINE CARE, INSPECTION, AND MAINTENANCE

The trolley must be inspected periodically for wear and its ability to support load. The inspection frequency will depend of the regularity of use. The trolley should be visually inspected for the following conditions. It should be inspected a least once a month:

- Side plate bending.
- Hanger wear, cracks and distortion.
- Worn bearings.
- Worn wheels.

To avoid injury and/or property damage, the trolley and beam should be inspected periodically.

3.0: INSPECTION BEOFRE INITIAL USE

3.1: INSTALLATION

Installation **MUST** be performed by a qualified person in accordance with ACI Hoist & Crane. Severe injury, death and/or property damage can result if the end trucks are not correctly installed. For service in this area, please contact:

ACI Hoist & Crane
757 S.E. 17th Street
Fort Lauderdale, FL 33316
Phone: 954-367-6116
Fax: 954-272-0334
Toll Free: 1-866-424-6478

Make sure to check that the power supply to which the trolley is to be connected matches the information shown on the identification plate located on the side of the trolley.

Before using the trolley, fill in the information below:

Model No.: _____
Serial No.: _____
Purchase Date: _____

3.2: MOUNTING LOCATION

Prior to mounting the trolley (and hoist) ensures that the trolley beam and its supporting structure are adequate to support the trolley, hoist, and its loads. If necessary consult a professional that is qualified to evaluate the adequacy of the suspension location and its supporting structure.

3.3: PRE-OPERATIONAL CHECKS AND TRIAL OPERATIONS

- Record Model, Serial Number, & Purchase Date in the space provided in this manual.
- Perform pre-operational checks for the trolley:
 - Confirm the adequacy of the rated capacity for all slings, chains, wire ropes and all other lifting attachments before use. Inspect all load suspension members for damage prior to use and replace or repair all damaged parts.
 - Ensure that trolley is properly installed on the beam, and stops for the trolley are correctly positioned and securely installed on the beam.
 - Ensure that all nuts, bolts, and split pins (cotter pins) are sufficiently fastened.
- Confirm proper operation
 - Before operating ensure that the trolley meets the Inspection, testing and Maintenance requirements of ANSI/ASME B30.16.
 - Before operating ensure that nothing will interfere with the full range of the trolley's operation.
- Proceed with trial operation to confirm proper operation.
 - Operate the trolley through its full range of motion. Make sure the trolley runs smoothly and does not bind.

4.0: OPERATION

4.1: TROLLEY CONTROLS

Push Trolley: Movement is controlled by pushing/pulling on the load or the hook of the attached hoist

Gear Trolley: When facing Trolley Hand Wheel:

- Pull down on the right side of the Hand Chain (clockwise rotation) to move the Trolley left.
- Pull down on the left side of the Hand Chain (counterclockwise rotation) to move the Trolley right.

Avoid collisions with the end stops or other Trolleys. Damage may result.

5.0: INSPECTION

5.1: GENERAL

The crane should be inspected at the beginning of each shift. All functional mechanisms should be in good working order. Check limit switches, brakes, electrical equipment and other SAFETY devices. Check crane operation without load. Any unusual sounds, vibrations, anything wrong or apparently wrong should be reported to the operator's supervisor immediately. Inspect hoist and trolley as recommended in the manufacturer's manual.

5.2: SERVICE & FREQUENCY INFORMATION

5.2.1: SERVICE INFORMATION

- Normal Service – Service which involves operating at less than a certain percentage of rated load and less than an unspecified frequency. Refer to the ANSI/ASME 30 volume for the specific definition of your application.
- Heavy Service – Service which involves operation within the rated load limit which exceeds normal service.
- Severe Service – Service which involves normal to heavy service with abnormal operating conditions.

5.2.2: FREQUENT/DAILY INSPECTIONS

Frequent/Daily inspections are visual examinations by the operator or other designated personnel with interval per the following criteria.

- Normal Service – Monthly
- Heavy Service – Weekly to Monthly
- Severe Service – Daily to Weekly
- Special or Infrequent Service – As recommended by a qualified person before and after each occurrence.

| Frequent Inspection Criteria |
|---|
| All functional operating mechanisms for proper operation, proper adjustment, and unusual sounds |
| Connection points between Hoist & Trolley in accordance with ANSI/ASME B30.16 |
| Hook(s) and hook latches in accordance with ANSI/ASME B30.10 |
| Hoist(s) attached to Trolley in accordance with ANSI/ASME B30.16 |

5.2.3: PERIODIC INSPECTIONS

Periodic inspections MUST be preformed by a 'Certified Technician'.

Visual inspection will be performed by a qualified person who will make records of apparent external conditions to provide the basis for a continuing evaluation.

A qualified person shall determine whether conditions found during inspection constitute a hazard and whether maintenance of the equipment is required.

- Normal Service – Yearly
- Heavy Service – Semi-Annually
- Severe Service – Quarterly
- Special or Infrequent Service – As recommended by a qualified person before and after each occurrence.

Written, dated and signed inspection reports should be maintained on all critical items; such as safety devices, brakes, hooks, ropes, chains, etc. All worn, damaged or malfunctioning parts should be repaired or replaced to maintain a SAFE operating crane. Warning labels affixed to the crane, hoist or trolley should be kept clean and visible at all times. Warning labels should be replaced if loose or illegible.

| Periodic Inspection Criteria |
|---|
| Requirements of frequent inspection |
| Loose or missing bolts, nuts, pins, or rivets |
| Worn, cracked, or distorted parts such as pins, bearings, wheels, shafts, gears, rollers, yokes, and bumpers. |
| Function, instruction and warning labels for legibility and placement. |

5.3: OCCASIONALLY USED TROLLEYS

Trolleys that are used infrequently shall be inspected as follows prior to placing in service:

- Trolley Idle MORE THAN 1 month, LESS THAN 1 year: Inspect per FREQUENT Inspection Criteria.
- Trolley Idle MORE THAN 1 year: Inspect per PERIODIC Inspection Criteria.

5.4: INSPECTION METHODS AND CRITERIA

This section covers the inspection of Push Trolleys & Gear Trolleys. The list of items in this section is based on those listed in ANSI/ASME B30.16 for Frequent & Periodic Inspection. These inspections are not intended to involve disassembly of the trolley. Such disassembly and further inspection should only be performed by a qualified person trained in the disassembly and re-assembly of the trolley.

| Trolley Inspection Methods & Criteria | | | |
|--|---------------------------------------|--|---------------------------------|
| Item | Method | Criteria | Action |
| Functional operating mechanism | Visual, Auditory | Mechanisms should be properly adjusted and should not produce unusual sounds when operated. | Repair or replace as required |
| Housing and Mechanical Components | Visual, Auditory, Vibration, Function | Trolley components including, suspension shafts, track wheels, track wheel axles, clevises, connection yokes, suspension bolts, shafts, gears, bearing, pins, rollers, and bumpers should be free of cracks, distortion, significant wear and corrosion. Evidence of same can be detected visually or via detection of unusual sounds or vibration during operation. | Replace |
| Side Plates | Visual | Must be free of significant deformation | Replace |
| Bolts, Nuts, Snap, Rings, and Split Pins | Visual, Check with Proper Tool | Bolts, Nuts, Snap, Rings, and Split Pins should not be loose. | Tighten or replace as required. |
| Track Wheel-Tread | Visual, Measure | Diameter of the inside and outside tread surface should not be less than the discard value. | Replace |
| Track Wheel-Gear | Visual | Teeth should not be cracked, damaged, or excessively worn | Replace. |
| Suspension Shaft | Visual, Measure | Suspension shaft should not be bent. Diameter should be worn by 10% or more. | Replace |
| Suspenders | Visual, Measure | Never use the suspender if its dimension of D2-D1, d or h exceed the limits | Replace |
| Cable Hangers | Visual | Cable Hangers should not be damaged or significantly worn. Movement should be smooth and should not cause the Power Supply Cable to twist or kink | Repair or replace as necessary |
| Pendant – Labels | Visual | Labels denoting functions should be legible | Replace |
| Warning Labels | Visual | Warning labels should be affixed to the pendant cord and they should be legible | Replace |
| Trolley Capacity Label | Visual | The label that indicates the capacity of the trolley should be legible and securely attached to the trolley | Replace |

6.0: MAINTENANCE & HANDLING

6.1: LUBRICATION

1. Lubricate the following trolley components with NLGI (National Lubricating Grease Institute) #2 or equivalent grease.
2. Track Gear Wheel- Clean and re-grease the Track Wheel gears and Hand Wheel output pinion every three months (more frequently for heavier usage or severe conditions). Do not use an excessive amount of grease and avoid getting any grease on the running surfaces of the Track Wheel or the beam.
3. Trolley Wheel Bearings do not need to be lubricated and must be replaced if worn or damaged.
4. Suspension Pins, Bolts, and Shafts – Grease at least twice per year for normal usage (more frequently for heavier usage or severe conditions).

6.2: STORAGE

The storage location should be clean and dry.

6.3: OUTDOOR INSTALLATION

- For trolley and hoist installations that are outdoors, the trolley and hoist should be covered and protected from the weather when not in use.
- Possibility of corrosion on components of the trolley increases for installations where salt air and high humidity are present. The trolley may require more frequent lubrication. Make frequent and regular inspections of the unit's condition and operation.

7.0: DIMENSIONS & SPECIFICATIONS

7.1: PUSH TROLLEY

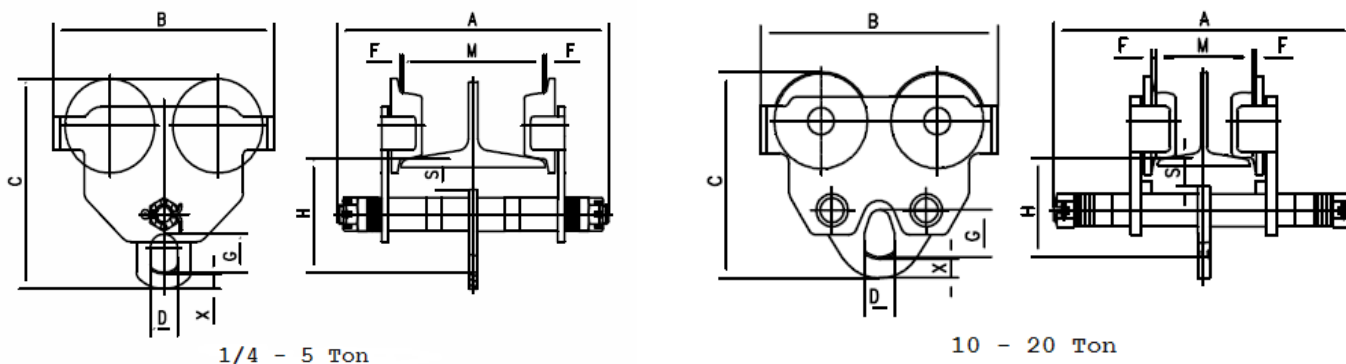

| Model | PT-005-S | PT-010-S | PT-020-S | PT-040-S | PT-060-S | PT-060-L | PT-100-S | PT-100-L | PT-200-L | PT-400-L | |
|----------------------------|----------|-------------|-----------|-----------|-----------|-----------|------------|-----------|------------|-------------|------------|
| Rated capacity (tons) | 1/4 | 1/2 | 1 | 2 | 3 | 3 | 5 | 5 | 10 | 20 | |
| Min. radius of curve (ft.) | 2.6 | 2.6 | 3.3 | 3.6 | 4.3 | 4.3 | 4.6 | 4.6 | 6.6 | 11.5 | |
| Diameter of wheel (in.) | 2.3 | 2.3 | 2.9 | 3.5 | 4.3 | 4.3 | 4.8 | 4.8 | 5.9 | 7.9 | |
| Dimensions (in.) | A | 9.6 | 9.6 | 12.2 | 12.9 | 13.5 | 17.5 | 14 | 18 | 20.1 | 23.8 |
| | B | 7.6 | 7.6 | 9.7 | 10.9 | 13.1 | 13.1 | 14.8 | 14.8 | 16.7 | 23.8 |
| | C | 7.4 | 7.4 | 8.7 | 10.3 | 12.2 | 12.2 | 13.9 | 13.9 | 15.6 | 19.6 |
| | H | 4.1 | 4.1 | 4.9 | 5.9 | 6.7 | 6.7 | 7.7 | 7.7 | 7.5 | 9.2 |
| | S | 1.2 | 1.2 | 1.5 | 1.5 | 1.6 | 1.6 | 1.7 | 1.7 | 1.8 | 2.3 |
| | D | 1 | 1 | 1.2 | 1.5 | 1.6 | 1.6 | 2 | 2 | 2.8 | 3.7 |
| | X | 0.63 | 0.63 | 0.63 | 0.75 | 0.88 | 0.88 | 1.13 | 1.13 | 2 | 3.5 |
| | G | 1.3 | 1.3 | 1.6 | 2 | 2.5 | 2.5 | 3 | 3 | 4.3 | 5.3 |
| | F | 0.10 - 0.12 | | | | | | | | 0.10 - 0.14 | |
| I-beam width range (in.) | M | 2.0 - 6.0 | 2.0 - 6.0 | 2.5 - 8.0 | 3.5 - 8.0 | 4.0 - 8.0 | 4.0 - 12.0 | 4.5 - 8.0 | 4.5 - 12.0 | 4.9 - 12.0 | 5.4 - 12.0 |
| Net weight (lbs) | | 15.4 | 15.4 | 26.5 | 48.5 | 66 | 80 | 85 | 100 | 205 | 518 |

7.2 GEAR TROLLEY

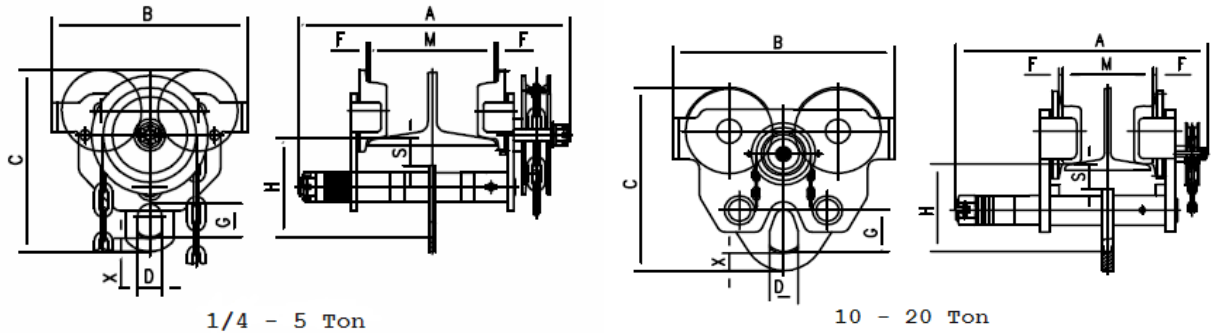

| Model | GT-005-S | GT-010-S | GT-020-S | GT-040-S | GT-060-S | GT-060-L | GT-100-S | GT-100-L | GT-200-L | GT-400-L | |
|----------------------------|----------|-------------|-----------|-----------|-----------|-----------|------------|-----------|-------------|------------|------------|
| Rated capacity (tons) | 1/4 | 1/2 | 1 | 2 | 3 | 3 | 5 | 5 | 10 | 20 | |
| Standard Hand Chain Drop | 8 ft. | | | | | | | | | | |
| Min. radius of curve (ft.) | 3.3 | 3.3 | 3.3 | 3.6 | 4.3 | 4.3 | 4.6 | 4.6 | 6.6 | 11.5 | |
| Diameter of wheel (in.) | 2.9 | 2.9 | 2.9 | 3.5 | 4.3 | 4.3 | 4.8 | 4.8 | 5.9 | 7.9 | |
| Dimensions (in.) | A | 13.3 | 13.3 | 13.3 | 13.7 | 14.3 | 18.3 | 14.7 | 18.7 | 20.1 | 23.8 |
| | B | 9.7 | 9.7 | 9.7 | 10.9 | 13.1 | 13.1 | 14.8 | 14.8 | 16.7 | 23.8 |
| | C | 8.7 | 8.7 | 8.7 | 10.3 | 12.2 | 12.2 | 13.9 | 13.9 | 15.6 | 19.6 |
| | H | 4.9 | 4.9 | 4.9 | 5.9 | 6.7 | 6.7 | 7.7 | 7.7 | 7.5 | 9.2 |
| | S | 1.5 | 1.5 | 1.5 | 1.5 | 1.6 | 1.6 | 1.7 | 1.7 | 1.8 | 2.3 |
| | D | 1.2 | 1.2 | 1.2 | 1.5 | 1.6 | 1.6 | 2.0 | 2.0 | 2.8 | 3.7 |
| | X | 0.63 | 0.63 | 0.63 | 0.75 | 0.88 | 0.88 | 1.13 | 1.13 | 2.00 | 3.5 |
| | G | 1.6 | 1.6 | 1.6 | 2.0 | 2.5 | 2.5 | 3.0 | 3.0 | 4.3 | 5.3 |
| | F | 0.10 - 0.12 | | | | | | | 0.10 - 0.14 | | |
| I-beam width range (in.) | M | 2.5 - 8.0 | 2.5 - 8.0 | 2.5 - 8.0 | 3.5 - 8.0 | 4.0 - 8.0 | 4.0 - 12.0 | 4.5 - 8.0 | 4.5 - 12.0 | 4.9 - 12.0 | 5.4 - 12.0 |
| Net weight (lbs.) | | 31.0 | 31.0 | 42.0 | 64.0 | 88 | 95 | 108 | 113 | 227 | 540 |

8.0: SPART PARTS: EXPLODED VIEW

8.1: GEAR TROLLEY

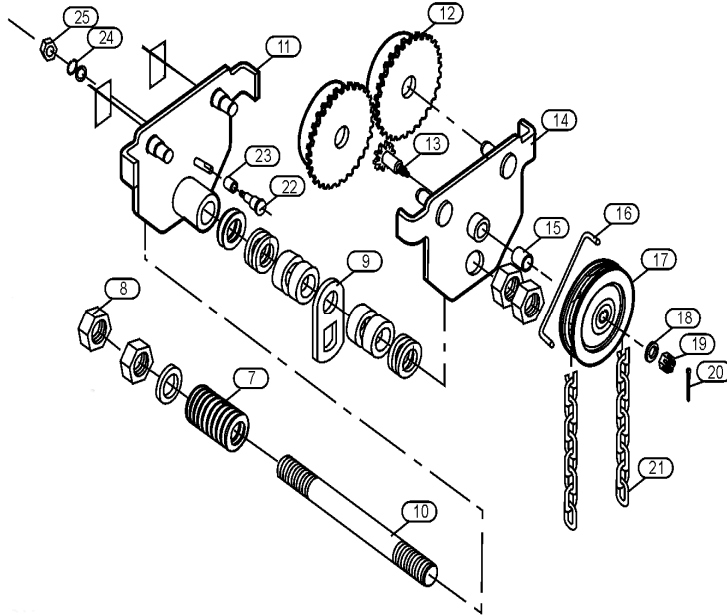

8.2: PUSH TROLLEY

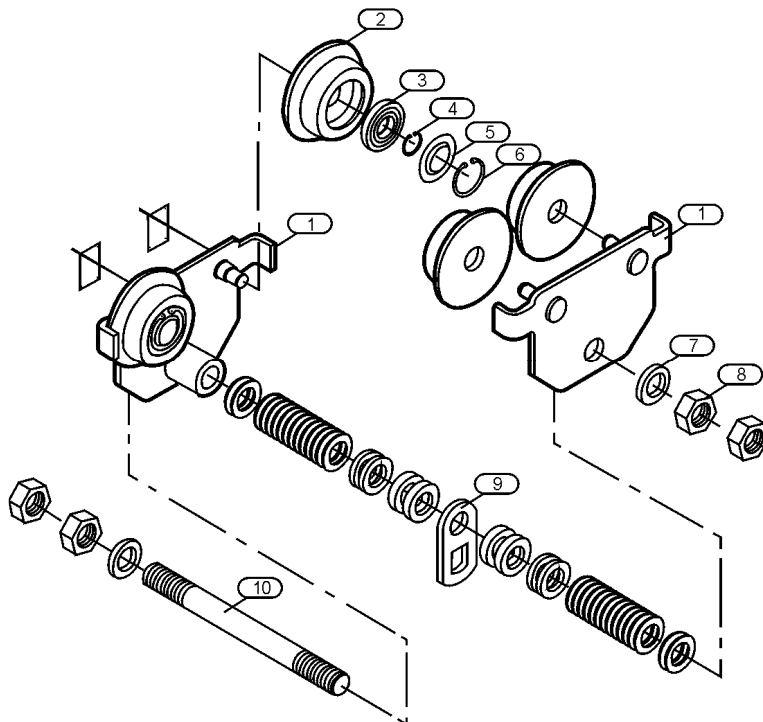

8.3: PARTS LIST

When ordering parts, please provide the Model Number & Serial Number located on the side of the Trolley.

| | | | |
|---------------------------|----------------------------------|-----------------------------------|-------------------|
| 1. Two gear case assembly | 8. Hex nut | 14. Right side gear case assembly | 20. Split pin |
| 2. Driven wheel | 9. Lifting ring | 15. Copper sleeve | 21. Chain |
| 3. Bearing | 10. Equalizer pin | 16. Catch pin | 22. Roll spindle |
| 4. Axle ring | 11. Left side gear case assembly | 17. Chain wheel | 23. Roll sleeve |
| 5. Bearing ring | 12. Tooth gear | 18. Spacer washer | 24. Spring washer |
| 6. Hole ring | 13. Driven spindle | 19. Hex castle nut | 25. Hex nut |
| 7. Spacer washer | | | |

9.0: WARRANTY

WARRANTY

Every trolley is thoroughly inspected and tested before it is shipped from the factory. If any problem develops within one-year return the complete trolley prepaid to the factory. If an inspection reveals that the problem is caused by defective workmanship or material, repairs will be made without charge and the trolley will be returned, transportation prepaid.

This warranty does not cover: (a) deterioration caused by normal wear, abuse, eccentric or side loading, overloading, chemical or abrasive actions, improper maintenance or excessive heat; (b) problems resulting from repairs, modifications or alterations made by people other than factory or ACI representative; (c) the trolley has been abused or damaged due to an accident; (4) repair parts or accessories other than ACI equipment are used on the trolley. Equipment and accessories not of the seller's manufacture are warranted only to extent that they are warranted by the manufacturer.

EXCEPT AS STATED HERE, ACI MAKES NO OTHER WARRANTIES, EXPRESS OR IMPLIED, INCLUDING WARRANTIES FOR A PARTICULAR PURPOSE