

LIFTING MAGNET

OPERATING, MAINTENANCE, & PARTS MANUAL



ACI Hoist & Crane
757 Southeast 17th Street
Fort Lauderdale, FL 33116
Phone: 954 -367-7116
Fax: 954-272-0334
www.ACIIHoist.com

Table of Contents

SECTION	PAGE
1 Information & Features.....	5
1.1 General Information.....	5
1.2 Special Features.....	5
2 Safety Information.....	6-7
2.1 Safety Guidelines.....	6
2.2 Safety Factors.....	7
3 Operation & Maintenance Information.....	7-8
3.1 Operation & Inspection Information.....	7
3.2 Maintenance & Handling Information.....	8
4 Ordering & Dimensions.....	8-9
4.1 Ordering Parts.....	8
4.2 Dimensions & Specification.....	9
5 Safety Curve Capabilities.....	9-12
5.1 Actual Capacity Value.....	9
5.2 Steel Thickness Information.....	10
5.3 Air Gap Information.....	11
6 Helpful Facts.....	12
7 Warranty Information.....	12

1.0: INFORMATION & FEATURES

Please read the Operating Instructions carefully before using this Product. If any doubt remains, please contact ACI Hoist & Crane for further details and information.

1.1: GENERAL INFORMATION

The Lifting Magnet has strong magnetic path produced by Nd-Fe-B magnetic materials. The 'On' and 'Off' magnetic path is controlled by turning the handle manually. It uses the magnet as power. In essence, lifting power will never weaken.

An external power source is not required which means that Lifting Magnets can be used virtually anywhere. The Lifting Magnet is mainly used for connecting component during lifting and handling operation. They can elevate moving iron block, cylindrical and other magnetic material.

It is very convenient for functions such as loading, unloading, and moving. In essence, the ideal usage of a Lifting Magnet is handling steel plates, die castings, forgings, etc. They eliminate the need for using a clamping tool, slings, or chains. They are easy for operation, safe in handling, lightly and ingeniously structured. Hence, they are widely used as hoisting devices in factories, docks, warehouses, and transportation industries. By using them, you can improve your working conditions and increase your working efficiency.

1.2: SPECIAL FEATURES

- Without power, there is NO risk in the condition of no electrical source.
- Use of high-energy magnetic material ensures a compact, lightweight and durable design.
- Simple locking witch handle enable safe, quick and easy one-handle operation.
- Very low residual magnetism for quick and efficient handling of work pieces
- Large shackle top fitting for easy attachment of slings and rigging
- V slot in bottom lifting face for lifting rounds as well as flats
- Clear markings of duration for varying shaped work pieces, lifting conditions, air gap, steel thickness, etc.
- Individually fully proof load tested by ACI Hoist & Crane.

2.0: SAFETY INFORMATION

2.1: SAFETY GUIDELINES



The lifting magnet face and the lifting contact area on the load must be clean.

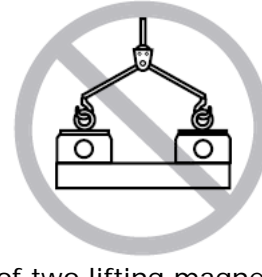

No hooking of two lifting magnets without the use of a properly designed spreader beam.



The operator should avoid carrying the load over people.



Care should be taken to make certain the load is correctly distributed for the lifting magnet being used.



Nobody must be allowed to stand on top of lifted work-piece.



Avoid placing the magnet in shear.



Do not allow load or magnet to come into contact with any obstruction.



Avoid uneven lifts.

2.2: SAFETY FACTORS

Published lifting magnet capacities represent ultimate lift strength- the lifting capacity of the magnet on different loads UNDER IDEAL CONDITIONS- unless clearly specified otherwise.

It would be impossible to foresee all varying conditions of operations from one installation to another and try to rate the magnet for each and every possible condition of operation. Instead, the magnet operator must do this by applying a Safety Factor to ultimate lift strength of the magnet, making sure that the safety factor applied represents actual conditions as much as practical.

Some of the operating conditions that dictate the applicable safety factor are:

1. Surface condition of load
2. Surface condition of magnet
3. Smoothness of lift
4. Flatness and stiffness of load
5. Centering of load on magnet
6. Environment
7. Voltage fluctuations (for electromagnets)

When any of these conditions are anything but ideal, the operator must apply a safety factor that will account for corresponding adverse effects on the ultimate lift strength of the magnets.

3.0: OPERATION & MAINTENANCE INFORMATION

3.1: OPERATION & INSPECTION INFORMATION

1. Clean up the lifting magnet bottom and surface of the steel load to be lifted, because rust, burr, paint, or dirt could reduce lifting power a lot.
2. Carefully place lifter on the steel load without any impact. Centerline the Lifting Magnet should overlap with weight centerline of the steel load.
3. Press the button at top of the handle and turn it from "off" position to "on" position until a "Safety Key" of the handle passes a "Lock Pin" on the lifter body. Thus the handle has been locked at "On" position by the Lock Pin, keeping the lifter having attraction power to the steel load.
4. Slowly hoist and carry your steel load to destination.
5. After settling the steel load at destination, press the button on top of the handle and turn the handle back to "off" position to release the steel load.

Before using the lifting magnet, fill in the information below:

Model No.: _____
Serial No.: _____
Purchase Date: _____

3.2: MAINTENANCE & HANDLING INFORMATION

1. Don't turn the handle without steel load under the bottom of the lifting magnet.
2. Dropping, heating and shocking could cause permanent damage to the Lifting Magnet.
3. Protect magnetic poles from rusting with oil after use. Store Lifting Magnet in an area free of metal chips, grit and moisture.
4. Inspect mechanical condition of the Lifting Magnet and magnetic poles surface prior to use. The surface must be clean and flat without any damages.
5. Check handle to make sure the Safety Key moves smoothly by pressing the button on top of the handle while the Lifting Magnet is placed on load.
6. Annual calibration check is recommended.

4.0: ORDERING PARTS & DIMENSIONS

4.1: ORDERING PARTS

When ordering Parts, please provide the Lifting Magnet's Model Number & Serial Number located on the Lifting Magnet's nameplate.



4.2: DIMENSIONS & SPECIFICATIONS

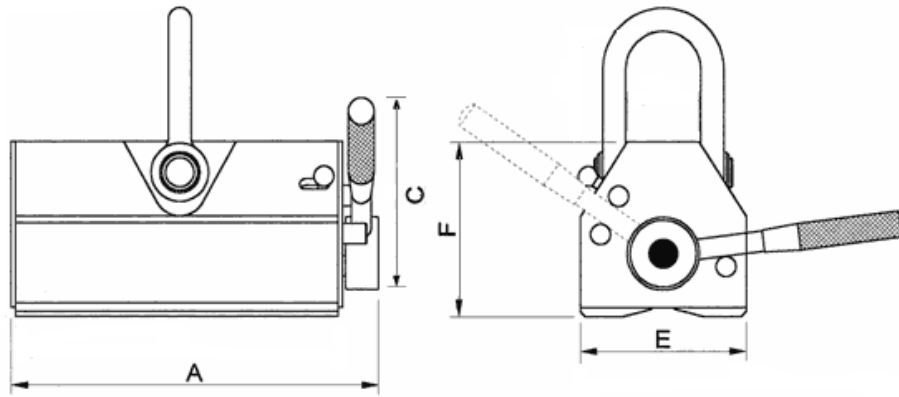

Model	PML-1	PML-3	PML-6	PML-10	PML-20	
Lifting Capacity (lbs)	220	660	1320	2200	4400	
Max rated load for round steel (lbs)	99	297	594	990	1980	
Max rated load for flat steel (lbs)	220	660	1320	2200	4400	
Max "Breakaway force" (lbs)	N/A	2315	4629	7716	15432	
Distance (in)	A	3.6	6.4	9.1	10.2	14.9
	C	5.7	5.9	7.7	11.2	16.8
	E	2.5	3.6	4.8	6.9	9.2
	F	2.8	3.5	4.6	6.4	8.3
Net Weight (lbs)	7	22	53	110	275	

5.0: SAFETY CURVE CAPABILITIES

5.1: ACTUAL CAPACITY VALUE

The lift value of the Lifting Magnet is affected and reduced by the following factors: in all applications:

Thickness (see Table 1 below)	Air Gap (see Table 2 below)	Carbon Composition	Round Bar or Pipe	Sheet
The lift mild steel plate: <i>refer to Table 1 and Chart 1 below.</i>	An Air Gap between the Lifting Magnet and the steel load produced by paint, dirt, roughness, or uneven surface of a load: <i>refer to Table 2 below.</i>	When there is a lift of high Carbon steel, the lift value will be 30% less. If lifting a cast iron, lift value will be 50% less.	A Round bar must contact the V shape slot at the bottom of the Lifting Magnet with the two lines. Also, the actual capacity value will be approximately 40% of that plate. When lifting pipes, its thickness should also count. The actual capacity value is also affected by the diameter of the round load.	A large but thin steel sheet can be bended in an arc profile and then peeled off when lifted, even though it is light. When lifting a sheet from a stack, the magnetic flux may penetrate through the sheet and cling lower pieces. This is an unsafe condition.

5.2: STEEL THICKNESS

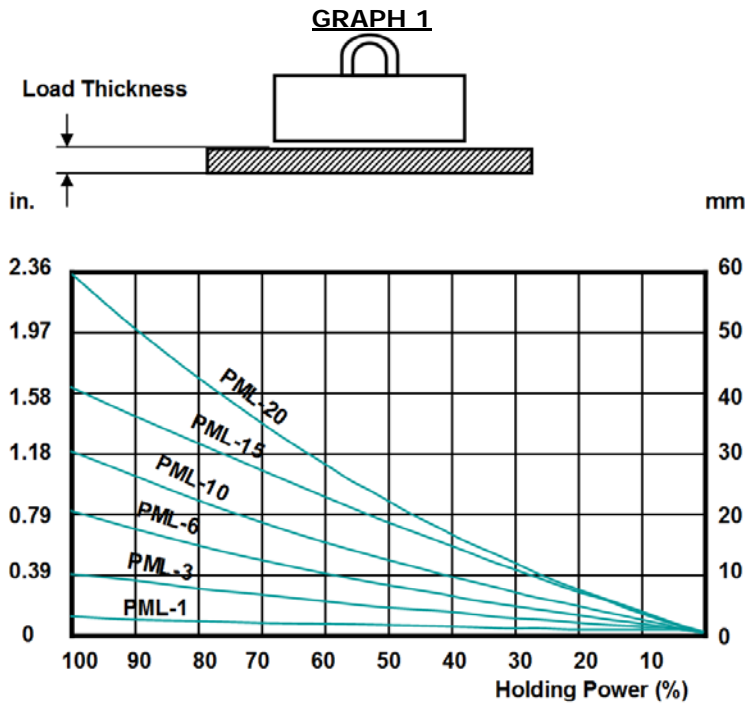

TABLE 1: ACTUAL CAPACITY

PML-3: Nominal Capacity 660 lbs		
Minimum Thickness (in)	Holding power	Actual capacity (lb)
1/8	40	264
1/4	70	462
3/8 & up	100	660

PML-6: Nominal Capacity 1320 lbs		
Minimum Thickness (in)	Holding power	Actual capacity (lb)
1/8	20	264
1/4	40	528
3/8	60	792
5/8	85	1122
3/4	95	1254
1 & up	100	1320

PML-10: Nominal Capacity 2200 lbs		
Minimum Thickness (in)	Holding power	Actual capacity (lb)
1/8	15	330
1/4	30	660
3/8	40	880
5/8	65	1430
3/4	70	1540
1	87	1914
1 1/4 & up	100	2200

PML-20: Nominal Capacity 4400 lbs		
Minimum Thickness (in)	Holding power	Actual capacity (lb)
1/8	10	440
1/4	20	880
3/8	25	1100
5/8	40	1760
3/4	45	1980
1	55	2420
1 1/4	65	2860
1 1/2	75	3300
2	92	4048
2 1/4	98	4312
2 1/2 & up	100	4400

5.3: AIR GAP

GRAPH 2

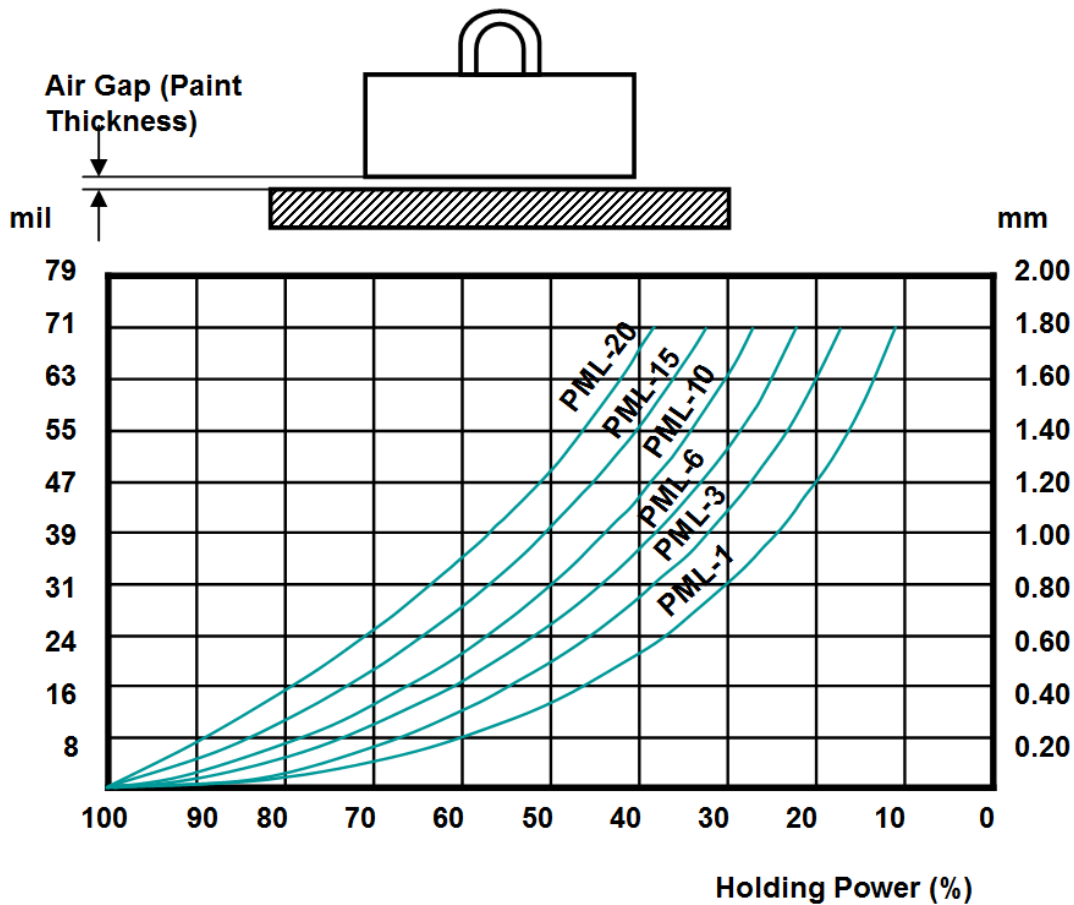

1 mil = 0.001 inch
 Standard paint thickness is 5-8 mils per coat

Formula for Range of Lifting Capacity is:

$$\text{Actual Capacity} = \text{Nominal Capacity (lbs)} \times \text{T Factor (\%)} \times \text{A Factor (\%)}$$

T Factor = Thickness Holding Power (%)

A Factor = Air Gap Holding Power (%)

Example: PML-600 rated lifting power is 1,320 lbs.

3/8" Thickness Plate means T Factor (%) = 60%

(Note: see Graph 1)

1)

Standard Paint Thickness is 8 mils mean A Factor (%) = 90%

(Note: see Graph 2)

$$\text{Actual Capacity} = 1320 \text{ (lbs)} \times 60 \text{ (\%)} \times 75 \text{ (\%)}$$

$$\text{Actual Capacity} = 594.0 \text{ lbs}$$



Please consider the Air Gap when choosing your Lifting Magnet

6.0: HELPFUL FACTS

Regarding Weight, Shape, & Area of Load:

- The number of poles a magnet has is determined by its intended use. As a general rule of thumb, the more “poles” on the face of the magnet, the shallower the magnetic field. A two-pole magnet (ACI PML’s are two-poles) typically has a deeper field (extending farther from the face) than a magnet with 3 or more poles. The design of the magnet circuit determines the depth of the magnet field produced.

Regarding the Surface Condition:

- Anything that prevents the face of the magnet from making full contact with the part being lifted is considered an “air gap”. Rust, dirt, ice, snow, machine grooves and holes are just a few examples of an “air gap”. It is recommended the magnet make full contact with a “clean” part before lifting.

Regarding Sizes and Shapes:

- “Breakaway force” is the force required to separate the load from the magnet when pulled in a direction perpendicular to the magnet’s face. The breakaway force of a lifting magnet is proportional to the thickness of the material being lifted. A magnet’s breakaway force increases until the material being lifted exceeds the saturation thickness. Accordingly, thinner materials will not yield a greater breakaway force.

Regarding Safety:

- The holding force for a magnet is affected by the composition of the material being lifted. Alloys with higher iron content are typically more susceptible to magnetic fields than those with lower iron content. Know the material you are lifting.

7.0: WARRANTY

Every Lifting Magnet is thoroughly inspected and tested before it is shipped from the factory. If any problem develops within one-year return the product prepaid to the factory. If an inspection reveals that the problem is caused by defective workmanship or material, repairs will be made without charge and the product will be returned, transportation prepaid.

This warranty does not cover: (a) deterioration caused by normal wear, abuse, eccentric or side loading, overloading, chemical or abrasive actions, improper maintenance or excessive heat; (b) problems resulting from repairs, modifications or alterations made by people other than factory or ACI representative; (c) the Lifting Magnet has been abused or damaged due to an accident; (4) repair parts or accessories other than ACI equipment are used on the product. Equipment and accessories not of the seller’s manufacture are warranted only to extent that they are warranted by the manufacturer. EXCEPT AS STATED HERE, ACI MAKES NO OTHER WARRANTIES, EXPRESS OR IMPLIED, INCLUDING WARRANTIES FOR A PARTICULAR PURPOSE.

